

Owner's manual

Ferrari _____
California **T**



Important note



For information on the location of FERRARI Dealers and Authorised Service Centres, visit the website www.ferraridealer.com or the Customer Care Service available at the numbers indicated in the “Reference Guide” booklet.





General remarks

This vehicle, which complies with EC homologation parameters, uses advanced technology and is capable of achieving high performance levels.

It is equipped with sophisticated active and passive safety systems (described below).

These safety features and systems do not authorise the driver to take risks other than those involved in normal driving since their preventive and protective action is guaranteed only in certain conditions. Unless otherwise instructed specifically by **FERRARI** (see the Safety chapter), the deactivation of any of the vehicle's safety systems is **PROHIBITED**.

While certain safety systems (e.g. the airbags) have been tested to ensure that they offer the highest possible levels of protection, they may nonetheless be hazardous in the event of failure by the driver or passenger to observe the instructions given by **FERRARI**. All vehicle occupants must be attentive at all times and take particular care when transporting passengers who are more subject to injury such as children, disabled and elderly persons.

Safe driving is subject to the following conditions **AT ALL TIMES**:

- the driver must be in perfect psycho-physical condition;
- road regulations (Traffic Regulations - Vienna Convention on Road Traffic that ended on 8 November 1968) must be strictly observed;
- common rules of caution must always be observed in relation to the quality/performance of the vehicle, driving conditions and contingent situations.

- Caution and discipline are the basis of safe driving.
- Driving takes place in a naturally dangerous context in which a number of different risk factors interact. For this reason, drivers must drive bearing in mind that others, whether they are pedestrians, motorcyclists or motorists, can make mistakes. Keeping a safe distance allows emergency measures to be taken. Remember that national and international legislation requires that the driver of the vehicle must be capable of performing corrective and/or emergency manoeuvres at all times.
- Correct and careful use of a vehicle derives, above all, from respect for one's own safety and that of others as well as from compliance with road regulations. Only this respect will help you experience all the emotions that driving this car can offer you.

The driver **MUST NEVER** allow passengers to increase the risks associated with driving (e.g. by not using safety systems such as the seat belts) by failing to observe the mandatory safety rules that apply to both driver and passengers.

The vehicle **MUST NOT** be modified or tampered with for any reason whatsoever since, by so doing, the manufacturer's homologation and safety parameters will be modified.



The driver must pay the utmost attention to the signals of the vehicle and, in particular, the warning lights on the dashboard and buzzers. Even when the warning lights do not indicate a situation of immediate danger, the driver must be cautious in relation to possible consequences/degeneration of the failure and other information given.

During routine operations, such as refuelling, precautions should always be taken and it is important to check that flammable liquid has not been spilled; these precautions must be observed even if the operation is performed by others. Similarly, before setting off make sure that the doors are closed by checking the warning lights and also manually. The driver must be fully acquainted with the vehicle and its controls in order to handle and drive it correctly. Command of the vehicle can be acquired/improved by attending the driving courses held by **FERRARI** which we strongly recommend.

The use of terms from the motor sports world (such as F1, SPORT and RACE) is merely indicative of the vehicle's competition-derived technology and does not endorse inappropriate behaviour on the road which does not comply with Traffic Regulations. Sports-style or SPORT or RACE mode driving refer to road driving.

Most accidents are caused by distraction. The driver must use any on-board information, communication and entertainment systems responsibly, especially when the vehicle is in motion. Examples of information, communication and entertainment systems are the following: satellite navigation systems, traffic information systems (e.g. ITT), media players (e.g. iPod), telephones with Bluetooth connectivity, etc. (whether merely audio-based or with display).

It is important to bear in mind that on-board systems may be distracting when driving since they may take a driver's attention off the road for several seconds. Aftermarket video entertainment systems for the passenger (e.g. TV) must be installed where they cannot distract the driver while the vehicle is in motion. While the vehicle is in motion, the attention required to use on-board systems must never exceed the high level of attention required to drive safely in accordance with the Traffic Regulations.

Therefore, these systems may only be used (separately or in combination with others) by the driver:

- in complete safety (stopping the vehicle before use if necessary). Operations that are not involved with driving (e.g. changing dashboard functions), must be performed in maximum safety when the vehicle is stationary;



- putting road safety first; for example, under conditions of poor or limited visibility, looking at a display with active programmes can be distracting even if you take your eye off the road only for a split second;
- ensuring, if the previous vehicle owner has installed systems on the vehicle that are **NOT APPROVED** by **FERRARI** (car tuning), that they are fully compatible with the original vehicle equipment.

If the vehicle owner has installed one or more new systems, either fixed or removable, on the vehicle, make sure that these

- have the necessary certification;
- are fully compatible with the original vehicle equipment (i.e. they do not interfere with it);
- are fitted by skilled staff.

The **FERRARI TECHNICAL SERVICE DEPARTMENT** and **FERRARI DEALERS** and **AUTHORISED SERVICE CENTRES** can provide all the information needed to ensure that they are compatible.

Strict priority criteria must be observed when driving a vehicle: you must not therefore take your attention off the road.

In some countries, the use of entertainment/information systems is prohibited on vehicles when driving.

The driver is responsible for use of these entertainment/information systems with video screens if they are prohibited in the country where the vehicle will be driven.

These considerations are not exhaustive, but only refer to some general issues that will be specifically dealt with in this Owner's Manual.



Introduction

The aim of this Owner's Manual is to help you get the best value from your vehicle and to provide information on routine maintenance: we advise you to read it carefully before setting out. The Owner's Manual should be considered an integral part of the vehicle and must therefore always be kept on board.

Using the product in a way that does NOT comply with the Owner's Manual not only exonerates **FERRARI** of any responsibility but also puts the person at great risk.

Due to its performance characteristics, the vehicle should not be driven by inexperienced drivers who have not received proper training.

Special care should be taken when giving the vehicle to third parties so that they are not put at risk. The vehicle can also be damaged if used in a way that does not comply with the instructions given above.

Updating

The high quality level of the vehicle is subject to constant technological improvements. Therefore, there may be differences between this manual and your vehicle.

The **FERRARI SALES AND SERVICE NETWORK** will provide you with all the information on any updates.

All specifications and illustrations contained in this manual are accurate as of the date of printing.

Spare parts

When replacing parts or topping up with lubricants and fluids, we recommend that you use original spare parts and lubricants and fluids recommended by **FERRARI**.

Warranty Booklet

Each new vehicle comes with a "Warranty Booklet".

This contains the vehicle's warranty validity conditions.

This warranty does not affect the buyer's statutory rights as a consumer, which derive from binding legal norms in his or her favour, in the various states or countries, or from European Union regulations, towards the Dealer.

The Warranty Booklet also contains the routine maintenance indicated in the "Maintenance Schedule".



Service

The information in this manual is necessary for the use and proper care of the vehicle. In addition, Customers will get maximum satisfaction and results from the vehicle if they carefully follow the instructions contained in it.

We recommend that you have all the checks and services performed at **FERRARI AUTHORISED WORKSHOPS** since they have highly skilled staff and the necessary equipment.

In the case of erroneous maintenance or repairs (that do not conform to the technical repair standards and procedures adopted by **FERRARI**), undertaken by independent repair centres, particularly if concerning safety systems or safety, **FERRARI** may decide to not carry out further repairs on the vehicle, unless the vehicle is restored so that it conforms to original parameters.

The Customer Care Service, available at the numbers indicated in the “Reference Guide” booklet enclosed with the vehicle documents, can provide information on the location of the **FERRARI DEALERS** and **AUTHORISED SERVICE CENTRES**.

The **FERRARI TECHNICAL SERVICE DEPARTMENT** is at your complete disposal for any information and advice. If you have any doubts about the information provided in this manual or how to use or operate the vehicle, please contact the **FERRARI SERVICE NETWORK**.

Consulting the manual

To facilitate reading the manual, the topics have been divided into sections and chapters.

1. *General*

Provides general information about your vehicle.

2. *Safety*

Describes the main safety systems in the vehicle.

3. *About your Vehicle*

Provides all necessary information for use of the vehicle.

4. *Advice for Emergency Situations*

Provides useful advice for solving problems that may occur.

5. *Care of the vehicle*

Provides advice for cleaning, care and routine maintenance of your vehicle.

6. *Glossary*

Explains the main technical concepts.

7. *Table of Contents*

Allows you to quickly identify and locate the information required.

Within the various sections, special attention must be paid to the parts marked as follows:

Warning



Extreme caution required: failure to comply with the instructions could constitute a serious risk to personal safety and vehicle protection!

Important note



Important note: a note containing instructions or information.

Environment



Warning for environmental protection: useful advice for protection of the environment.



Environmental protection

Environment



The following chapter contains useful advice for environmental protection.

FERRARI has designed and constructed a vehicle using technologies, materials and devices capable of reducing the harmful impact on the environment to a minimum.

If you use your vehicle with respect for the environment, you too will contribute to environmental protection.

Fuel consumption as well as engine, gearbox, brakes and tyres wear mainly depend on two factors:

- use of the vehicle;
- driving style.

Both factors are influenced by the driver.

Use of the vehicle

- Avoid using the vehicle for short trips.
- Check that the tyre pressure is correct.
- Check the fuel consumption.
- Proper periodic maintenance will contribute to preserving your vehicle in full working order and to protecting the environment. We therefore advise you to respect the service due dates indicated in the “Maintenance Schedule”.

Driving style

- Do not accelerate during the starting procedure.
- Do not warm up the engine when the vehicle is stationary.
- Drive carefully and keep a safety distance that corresponds to the driving speed.
- Avoid sudden and frequent acceleration or braking
- Turn off the engine if the vehicle is kept stationary for long periods of time.
- Shift gears using only 2/3 of the speed permitted for each gear.
- Use the air conditioning in moderation.
- A driving style like that described above protects the vehicle from premature wear and tear, makes driving safer and does not subject the vehicle to undue fatigue.

Important note



The vehicle is equipped with exhaust gas control and monitoring systems which must always be kept in perfect working order and controlled regularly.



Directive for the treatment of end-of-life vehicles (EU only)

For many years, FERRARI has been globally committed to respecting and protecting the environment by constantly improving its manufacturing processes and developing increasingly eco-compatible products.

Regulations for the treatment of end-of-life vehicles, implemented in response to the terms of EU Directive 2000/53, require that producers (manufacturers and official importers) collect all the vehicles introduced on the market by the producers themselves at the end of their life cycle, and ensure that these vehicles are processed in an environmentally compatible manner.

To hand over your FERRARI at the end of its life cycle for treatment at no additional cost (excluding deregistration and transport), take your vehicle to the nearest FERRARI dealer, which will, at its own expense, transport the vehicle to one of the authorised collection and demolition centres, which have been selected to ensure that all processes for the collection, treatment and recovery of recyclable materials are carried out in an environmentally compatible manner.

For further information, visit www.ferrari.com.

When handing over a FERRARI vehicle at the end of its life cycle:

- the vehicle must be complete, containing all the essential elements such as the engine, transmission, bodywork, ECUs and catalytic converters;
- the vehicle must not contain any additional refuse.

FERRARI is committed to offering its clients a geographically extensive and, as a result, better service, and thanks you for your cooperation in this environmental challenge.

Bear in mind that specific regulations govern the disposal of vehicle parts including batteries, tyres, used oil, etc.

Please contact the **FERRARI SERVICE NETWORK** for more information.

1. General

2. Safety

3. About your Vehicle

4. Advice for Emergency Situations

5. Care of the vehicle

6. Glossary

7. Table of Contents





Vehicle keys

The vehicle is delivered with two identical keys that can be used for:

- central door locking;
- starting the vehicle;
- activating/deactivating the alarm system;
- opening the luggage compartment.

Important note



If the keys are lost or stolen, you can request a duplicate from the **FERRARI SERVICE NETWORK** (see section “Duplicating the keys” on page 16).

Key codes

A **CODE CARD** is supplied together with the keys, indicating the following:

- the electronic code;
- the mechanical code for the keys, to be given to the **FERRARI SERVICE NETWORK** if you request duplicates of the keys.

Warning



The code numbers on the **CODE CARD** must always be kept in a safe and protected place, not accessible to others.

Important note



In the event of a change of ownership, it is essential that the new vehicle owner is provided with all the keys and with the **CODE CARD**.





Alarm system

The FERRARI CODE system

The vehicle is equipped with an electronic immobiliser system (FERRARI CODE) which is automatically activated when the ignition key is removed.

The keys are equipped with an electronic device which transmits a coded signal to the FERRARI CODE ECU. Once this ECU has recognised the signal, it allows the engine to start.

Operation

Each time the ignition key is removed from position **0** (see page 85), the protection system activates the engine immobiliser.

- When starting the engine, press the **ENGINE START** button on the steering wheel:

- 1) If the code is recognised, the **CODE** warning light **A** on the instrument panel turns off when the check procedure has been completed, whereas the **EOBD** warning light **B** turns off when the engine is started once the ECU has completed its diagnostic cycle; in these conditions, the protection system has recognised the key code and deactivated the immobiliser.
- 2) If the **CODE** warning light **A** stays on, it means that the code has not been recognised. If this occurs, it is advisable to turn the key back to position **0** and then back to **II**; if the immobiliser device remains active, try with the other key provided.

1

Important note



If you still cannot restart the engine, contact the **FERRARI SERVICE NETWORK**.

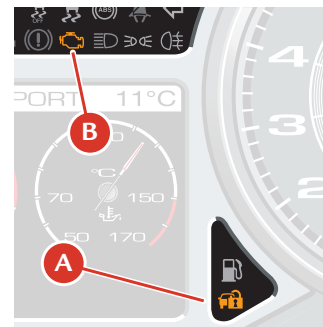



- While driving, with the ignition key in position **II**:

- 1) If the **CODE A** warning light turns on, it means that the system is performing a self-diagnostic cycle. At the first opportunity, you can stop and test the system: switch off the engine by turning the ignition key to position **0**, then turn the key back to position **II**: the **CODE** warning light **A** will turn on and should go off within one second. If the warning light stays on, repeat the procedure described previously leaving the key at **0** for more than 30 seconds.

Important note



If the problem persists, please contact the **FERRARI SERVICE NETWORK**.

- 2) If the **CODE** warning light **A** flashes, it means that the vehicle is not protected by the immobiliser.

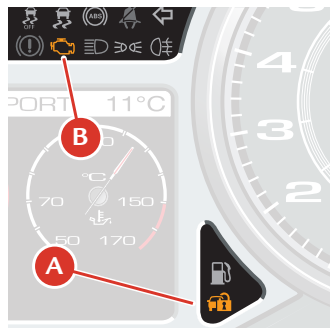

Important note



Contact the **FERRARI SERVICE NETWORK** immediately to have all the keys stored in the system memory.

Important note



Each key provided has its own specific code, which must be stored in the memory of the system control unit.

Duplicating the keys

If you request additional keys, provided that the conditions to satisfy your request are met, remember that the codes must be stored (up to a maximum of 7 keys) on all the keys. Contact the **FERRARI SERVICE NETWORK** directly and bring the following with you:

- all the keys in your possession;
- the **CODE CARD** for the **FERRARI CODE** system;
- a personal identity document;
- the documents proving ownership of the vehicle.

The codes for the keys that are not available when the new memorisation procedure is performed will be deleted from the memory to prevent any lost or stolen keys being used to start the vehicle.



Replacing remote control batteries

If you press one of the three buttons on the key and this does not activate the corresponding function, check that the alarm system functions are operating correctly by using the other remote control before replacing the remote control batteries.

Replace the remote control batteries as follows:

- open the key cover **C** using a small screwdriver at the position indicated by the arrow;
- remove the two batteries **E**, pushing in the direction indicated by the arrow to release them from the retainer cover **D**;
- fit two new batteries of the same type, observing the indicated polarity;
- close the key cover **C**.

Important note



Do not use sharp tools to remove the cover and be careful to avoid damaging the remote control.

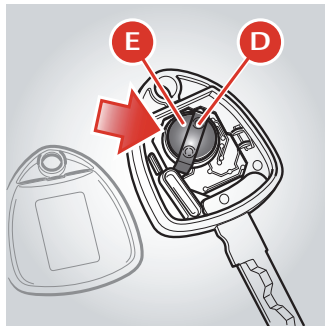
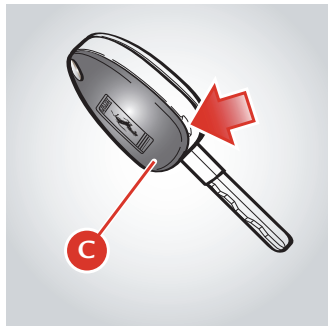

Electronic alarm

The electronic alarm system performs the following functions:

- remote control for central door locking/unlocking;
- perimeter surveillance, detecting if doors and lids are open;
- motion surveillance, detecting intrusion in the passenger compartment;
- vehicle movement surveillance.

Activation

To activate the alarm system, press button **F** on the ignition key:

- the turn indicators flash once;
- the system “beeps”;
- the red LED on the dashboard flashes;
- the central door locking system of the vehicle is activated and the doors are locked.

The system activates after approximately 25 seconds.

When the electronic alarm is activated, the user may request opening of the luggage compartment; in this case, the motion and anti-lift sensors are temporarily deactivated.

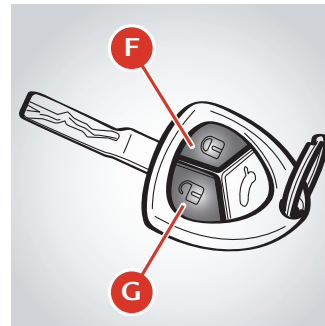



If the luggage compartment is then closed, the sensors will be reactivated.

If the turn indicators and the red LED on the dashboard flash 9 times when you activate the alarm system, it means that one of the doors or the front/rear lid is open or not closed properly and is therefore not protected by the perimeter surveillance. If this is the case, check that the doors and front/rear lids are closed properly and close any door or lid that is open without deactivating the alarm system: the turn indicators will flash once to indicate that the door and front/rear lids are now closed properly and protected by the perimeter surveillance.

Warning



If the turn indicators and the red LED on the dashboard flash 9 times when the alarm system is activated with the doors and front and rear lids properly closed, it means that the self-diagnostic feature has detected a malfunction in the system. Contact the FERRARI SERVICE NETWORK to have the system checked.

Deactivation

To deactivate the alarm system, press button **G** on the ignition key:

- the turn indicators flash twice;
- the system beeps twice;
- the red LED on the dashboard goes off;
- the cabin lights and the puddle lights come on;
- the central door locking system of the vehicle is deactivated and the doors are unlocked.

Pressing button **G** twice unlocks the doors and also turns on the low beams for 30 seconds.

The alarm system is off and you can now get into the vehicle and start the engine.

To enter the vehicle if the remote control battery is flat, insert the key into one of the two door locks and turn it to release the lock; the alarm siren will activate.

Start the vehicle following the standard procedures; The alarm siren will deactivate.

Deactivating the anti-lift volumetric alarm

Press button **H** to deactivate the volumetric sensors and anti-lift alarm system. When this function is deactivated, the indicator light on the button will flash for about 3 seconds and will then turn off.





Alarm memory

If, when the vehicle is started, the **CODE** symbol (see page 148) appears on the TFT display for 10 seconds after the system diagnosis cycle, together with the message “Break-in attempted”, this means there has been an attempt to break into the car, causing the alarm to activate.

In this case, the system will indicate the reason for the alarm activation according to the following priority:

- **LED off twice:** anti-lift sensor alarm;
- **LED off three times:** door alarm;
- **LED off four times:** luggage compartment lid alarm;
- **LED off five times:** ignition key alarm.

The alarm system memory is reset by turning the ignition key.

Ministerial homologation

The electronic alarm system complies with EU regulations on electromagnetic compatibility and is marked in compliance. The homologation number is referred to with the following characters.

For those markets that require the transmitter and/or receiver marking, the homologation number is found on the component.

Satellite alarm system (optional)

In some markets, the vehicle can be equipped, on request, with a satellite alarm system. If the vehicle is equipped with a satellite alarm system, please refer to the “Nav Trak Satellite Alarm System Quick Reference” booklet enclosed with the vehicle documents, for further information.

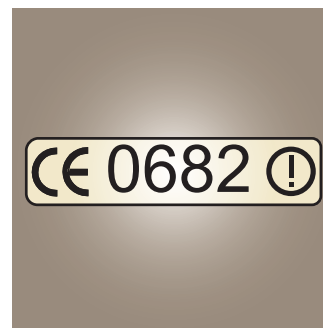



Identification and homologation plates and labels

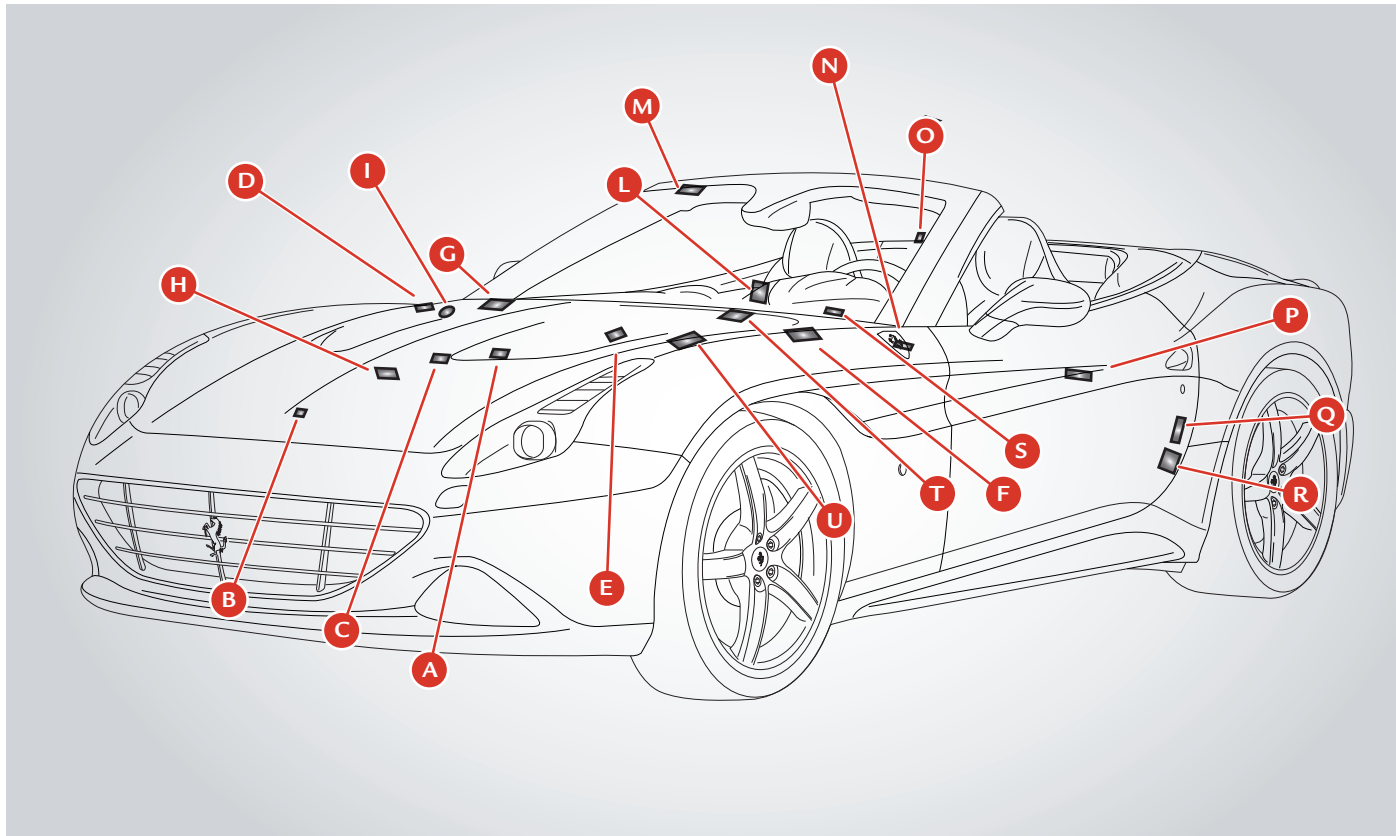



Ref.	Label/plate	Position
A	Engine type and number	Crankcase
B	Low-beam homologation	Engine compartment lid
C	Assembly number	Engine compartment
D	Radiator with antifreeze	RH engine compartment cosmetic shield
E	Checking the engine oil level	RH engine compartment cosmetic shield
F	Engine and gearbox oil label	RH engine compartment cosmetic shield
G	ECE homologation	Engine compartment lid
H	High voltage	Central engine compartment cosmetic shield
I	Installation of rearward facing child seat not allowed	Passenger-side dashboard side panel
L	Vehicle identification	Rear passenger-side door jamb
M	Passenger airbag warning (2)	Passenger-side sun visor
N	Chassis number	Chassis right-hand rear cross member
O	Unleaded fuel	Fuel filler flap
P	Gearbox type and number	Gearbox housing
Q	Tyre pressure and type	Driver-side door
R	TPMS present warning	Driver-side door
S	Chassis number	Windscreen
T	Original paintwork	Engine compartment lid
U	Stop&Start system warning (only with HELE)	LH engine compartment cosmetic shield



A Engine type and number



C Assembly number



B Low-beam homologation



D Radiator with antifreeze





E Checking engine oil level



G ECE homologation

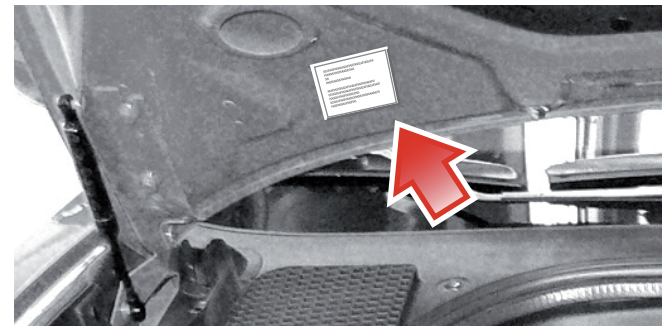

1

F Engine and gearbox oil label



H High voltage





O Unleaded fuel



Q Tyre pressure and type



1

P Gearbox type and number



R TPMS present warning





S Chassis number



U Stop&Start system warning (with HELE package only)



T Original paintwork





1

Dimensions and weights

Wheelbase	2670 mm
Max. length	4570 mm
Max. width	2109 mm
Max. height	1317 mm
Front track	1630 mm
Rear track	1605 mm
Front overhang	954 mm
Rear overhang	946 mm
Kerb weight	1770 kg *

* considering the most favourable OPT combination

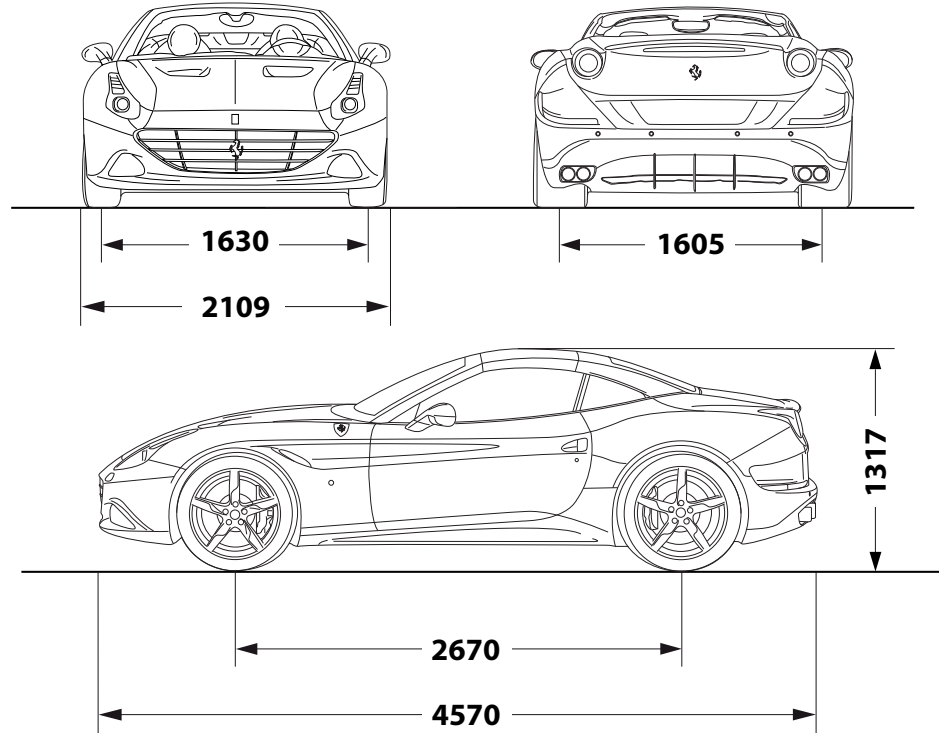



Main engine specifications

Type	F 154 BB
Number of cylinders	8
Cylinder sequence	V 90°
Cylinder bore	86.5 mm
Piston stroke	82 mm
Total displacement	3885 cm ³
Compression ratio	9.4:1
Max. RPM (with limiting device)	7500 RPM
Max. power (Dir. 1999/99/EC)	412 kW (560 hp) *
Corresponding RPM	7500 RPM
Max. torque (Dir. 1999/99/EC)	755 Nm
Corresponding RPM	4750 RPM

Consumption and CO₂ emissions

	Standard version		With HELE system	
	l/100 km	g/km	l/100 km	g/km
City cycle	17.8	415	15.5	362
Motorway	8.2	191	8.0	187
Combined cycle	11.7	273	10.7	251

Transmission ratios

Gearbox ratios	Differential/bevel gear pair ratio
1 = 3.397	
2 = 2.185	
3 = 1.626	4.444
4 = 1.286	
5 = 1.028	
6 = 0.839	
7 = 0.634	
R = 2.791	

Performance

0 - 100 km/h	Max. speed
3.6 s	> 315 km/h

Electrical system

Supply voltage	Alternator
12 V	Nippondenso 150 A SC2
Battery	Starter motor
Fiamm 12V - 100 A/h - 850 A	Nippondenso

*: value obtained with 98 RON unleaded fuel



Wheel rims and tyres

Wheel rims

Front	Rear	Space saver spare wheel
8" J x 19" ET 44	10" J x 19" ET 52.5	4.5" J x 20"
8" J x 20" ET 44	10" J x 20" ET 52.5	4.5" J x 20"

Explanation of wheel rim codes

Example: **8" J x 20" ET 44**







8" = Rim width in inches

J = Shape of rim edge (side projection where tyre bead rests)



20" = Rim diameter in inches

ET 44 = Offset (distance, in mm, between the centreline of the rim and inner rim surface)



FERRARI-approved tyres			<i>Inflation pressure (cold)</i>	 *	 *	 *
Pirelli PZero	Front	245/40 ZR19	2.40 bar	E	B	71 dB
	Rear	285/40 ZR19	2.20 bar	E	B	73 dB
Pirelli PZero	Front	245/35 ZR20	2.20 bar	E	B	72 dB
	Rear	285/35 ZR20	2.00 bar	C	B	73 dB
Optional tyres			<i>Inflation pressure (cold)</i>	 *	 *	 *
Bridgestone RE050A (Run-Flat)	Front	245/35 ZR20	2.40 bar	F	C	73 dB
	Rear	285/35 ZR20	2.40 bar	E	B	72 dB
Vredestein space saver spare wheel		145/60 R20	4.20 bar	-	-	-

**1**

Winter tyres			<i>Inflation pressure (cold)</i>	 *	 *	 *
Pirelli Winter Sottozero	Front	245/40 R19	2.40 bar	E	C	72 dB
	Rear	285/40 R19	2.20 bar	E	C	73 dB
Pirelli Winter Sottozero	Front	235/35 R20	2.10 bar	E	C	72 dB
	Rear	285/35 R20	2.00 bar	C	B	75 dB
Michelin Pilot Alpin	Front	235/35 R20	2.40 bar	E	C	70 dB
	Rear	285/35 R20	2.30 bar	E	C	75 dB

*: Regulation no. 1222/2009/EC (see page 34)



Explanation of codes and wording on tyre side walls

1) Tyre size and characteristics

Example: **245/35 ZR 20 (105Y)**

245 = Nominal width (distance in mm from side to side)

35 = Height/width ratio as a percentage

ZR = Radial tyre that can withstand speeds above 240 km/h. Combined with the specific load and speed code (in brackets), this indicates a tyre that can withstand speeds above 300 km/h.

20 = Rim diameter in inches

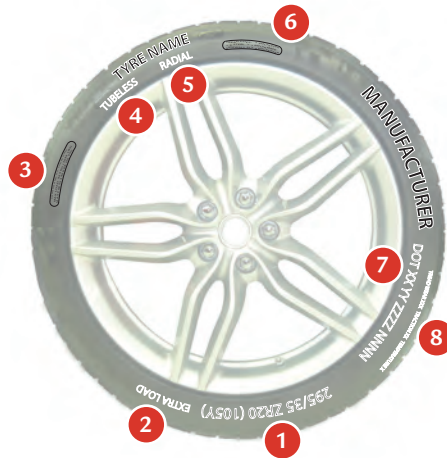

105 = Load index: numerical code associated with the maximum load permissible on the tyre at a given pressure, at the speed corresponding to the relative index. The maximum load permissible is indicated in kg and pounds in the wording (3).

Y = Speed index

This indicates the maximum speed at which the tyre can withstand the load indicated in the load index.

Speed indexes (ECE-UN 30) are shown in the table below:

Speed Index	Maximum speed (km/h)
M	130
N	140
P	150
Q	160
R	170
S	180
T	190
U	200
H	210
V	240
W	270
Y	300
ZR (... Y)	> 300

The speed index Y, shown in brackets and associated with the abbreviation ZR, indicates a tyre that can withstand speeds above 300 km/h.



- 2) **EXTRA LOAD:** tyre with a high load capacity
- 3) Maximum load permissible, indicated in kg and pounds, and maximum inflation pressure permissible, indicated in kPa and psi.
- 4) **TUBELESS:** the tyre has no air chamber
- 5) **RADIAL:** radial tyre
- 6) Details of materials used to construct the tread and tyre side wall.
- 7) **DOT XX YY ZZ NNNN**

DOT (Department Of Transportation) specifications: marking relative to US regulations, with information on the manufacturer, production site, tyre type and size. The last four digits, in a box, indicate the date of manufacture: 1011 means that the tyre was manufactured in the 10th week of 2011.

Warning



The **FERRARI SERVICE NETWORK** is suitably equipped to replace tyres, and to determine whether a tyre is safe for use. Only have the tyres replaced by the **FERRARI SERVICE NETWORK**, which has all the equipment necessary to prevent the risk of damage to the sensor inside the wheel rim, if installed (on vehicles with the TPMS tyre pressure and temperature monitoring system), caused by an inappropriately performed procedures.

- 8) **Uniform Tire Quality Grading:** standard, defined by the US Department of Transportation, that classifies tyre performance in terms of treadwear, traction and temperature resistance.

For further information on tyres, see page 258.



Regulation no. 1222/2009/EC (applies to EU countries only)

Regulation no. 1222/2009/EC states that all tyres sold in EU countries produced after 1 July 2012 must bear a label (as shown in the bottom right) containing important information on performance.

The aim of the regulation is to provide consumers with more information on safety (wet grip) and environmental (rolling resistance and external rolling noise) issues in order to promote the use of safer, quieter and more efficient tyres.

The label provides the following information:

Fuel consumption

The fuel consumption of a vehicle is influenced by the tyre rolling resistance. There is a scale with 7 levels, from A to G, on the left of the label where “A” indicates the best tyre class for reducing fuel consumption with lower rolling resistance.

Wet grip

On the right of the label, there is a scale for tyre performance when braking on wet roads. Measurements are taken under test conditions defined in the European Regulation. The scale has 7 levels, from A to G, where “A” indicates the maximum wet grip.

External rolling noise

The bottom of the label indicates the external noise level of the tyre. The external noise level is measured in decibels (dB) and is divided into 3 categories based on the new, stricter European levels of external tyre noise which will be introduced by 2016.

1 black sound wave: 3 dB below future European limit.

2 black sound waves: complies with future European limit.

3 black sound waves: complies with current European limit.

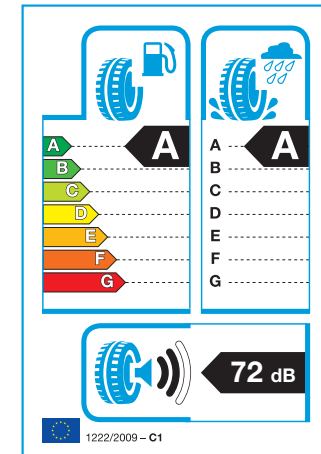



Run Flat tyres (optional)

The vehicle can be fitted with “Run flat” tyres, if required. This type of tyre has a reinforced side **A** which allows the vehicle to continue travelling at moderate speed (80 km/h), even after a puncture, for a specific distance (100 km).

When the instrument panel receives the “tyre puncture” information from the tyre pressure monitoring ECU, it calculates the residual tyre life and displays a warning in the dedicated area of the TFT display after 50 km.

After 100 km, a message warning the driver to stop the vehicle will be displayed (for further information, see the “Tyre pressure and temperature monitoring system” paragraph on page 71).

Warning



Observing the recommended wheel alignment values is essential in order to obtain the best performance and the longest life of these tyres.

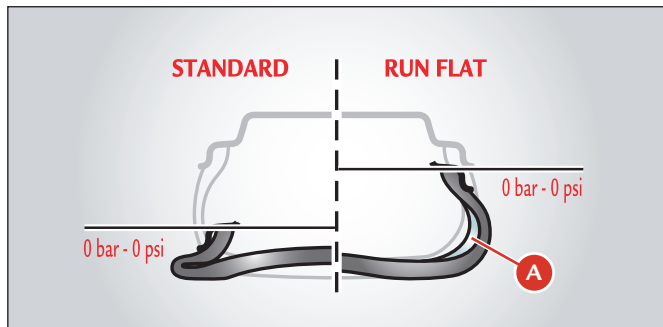

Warning



If you are going to use standard tyres on a vehicle that was originally equipped with “Run Flat” tyres, you must contact the **FERRARI SERVICE NETWORK** to have the dashboard reprogrammed and prevent warning messages being displayed on the left TFT display.

Environment



Maintaining correct tyre pressure helps to improve tyre rolling and reduce fuel consumption.



Refilling

<i>Parts to be refilled</i>		<i>Quantity</i>	<i>Complies with approval:</i>	<i>Recommended by FERRARI</i>	<i>Rif. pag.</i>
Engine	Total system capacity	13 l	Engine Oil SAE ¹⁾ 5W-40	SHELL HELIX <i>Ultra</i> 5W-40	253
	Oil level between Min. and Max.	1,3 l			
	Oil consumption	1,0 ÷ 2,0 l/1.000 km			
Gearbox and differential		3,5 l	Transmission fluid SAE ¹⁾ 75W-90	SHELL SPIRAX S5 ATE	255
Clutch system and hydraulic controls		7,75 l	DCT-F3	SHELL DCT-F3	
Braking system		1,1 l	DOT4 ²⁾	SHELL BRAKE AND CLUTCH <i>Ultra</i>	257
Cooling circuit		21 l	Anti-freeze coolant pre-diluted	GLYCOSHELL LONGLIFE al 50% + KEMETYL CARIX Premium C30 Longlife al 50%	255
Hydraulic power steering system		1,5 l	CHF 11S or equivalent	Pentosin CHF 11S	256
	Steering box	100 g	CHF 11S or equivalent	Pentosin CHF 11S	-
Fuel tank		78 l	Unleaded petrol (at least 95 R.O.N. ³⁾)		90
	Reserve	20 l			
RHT system	Total system capacity	0,4 l	CHF 11S or equivalent	Pentosin CHF 11S	-
	Oil level between Min. and Max.	65 ml			
Air conditioning and heating system	Compressor	165 cc	PAG ISO 46		-
	Coolant	470 ± 20 g	R 134 A	DELPHI RL 488 (R 134 A)	-
Windscreen washer/headlight washer fluid tank		6 l	Mixture of water and glass cleaner		258



- 1) **SAE - Viscosity class:** example SAE 5W - 40
5W = viscosity specification for low temperatures (winter)
40 = viscosity specification for high temperatures
- 2) **DOT - Designation of brake fluid:** denote a particular mixture of chemicals imparting specified ranges of boiling point.
- 3) **R.O.N. - Octane number:** is a standard measure of the antiknock performance of motor fuel.

Instructions for vehicle refuelling

Warning



Only fill the vehicle with unleaded petrol.

Using unleaded petrol is fundamentally important to ensure that the catalytic converters of the vehicle's exhaust system work properly.

Warning



Never put leaded petrol in the fuel tank, not even in emergencies: fuel deposits could irreparably damage the catalytic converters.

Environment



Inefficient catalytic converters produce harmful emissions at the exhaust and pollute the environment.

For optimal engine performance and efficiency, FERRARI strongly recommends using unleaded petrol with an octane rating (R.O.N.) of 98.

As unleaded petrol with a 98 R.O.N. is not always available, the engine can however be used with unleaded petrol with an octane rating of not below 95 R.O.N. In this case, the engine control system will appropriately adjust calibrations to allow the vehicle to function correctly but performance will be diminished.

Warning



The use of unleaded petrol with a R.O.N. below 95 can cause malfunctioning and is not recommended.

Important note



This vehicle is suitable for use with unleaded fuel with a maximum of 10% ethanol (E10).

Warning



The use of fuels with 10% to 25% ethanol can lead to malfunctioning.
The use of fuels with over 25% ethanol can cause permanent damage to the engine fuel system.

See page 90 for further information.



1. General

2. Safety

3. About your Vehicle

4. Advice for Emergency Situations

5. Care of the vehicle

6. Glossary

7. Table of Contents







FERRARI has designed and built a high performance vehicle.
In order to take advantage of the safety systems described below, it is essential to comply with the indicated regulations.

Special recommendations

This vehicle has been built to comply with homologation, personal safety and environmental regulations.
These high safety standards must always be accompanied by careful and cautious behaviour of the driver.

Particular attention must be paid to:

- Overheated components. High temperatures develop in the engine compartment in proximity of the exhaust system. Do not park the vehicle on paper, grass, dry leaves or other flammable materials. They could catch fire if they come into contact with hot parts of the exhaust system. Do not fit other heat shields or remove those fitted on the exhaust system. Do not let flammable substances come into contact with the exhaust system.
- Moving parts of the vehicle such as belts, fans, etc. They must always be adequately protected. Do not remove the guards or operate on the moving parts without taking due precautions.
- Installations under pressure such as braking system, air conditioning system, cooling system and lubrication system may create pressures inside them. Do not perform any operation which may cause gas or liquids to spill out with the risk of injury to persons and damage to things.

Emissions

Warning



- The exhaust gas generated by the running engine may be hazardous, especially when in closed spaces. As well as consuming oxygen, the engine discharges carbon dioxide, carbon oxide and other toxic gases.
- Fuel is highly inflammable and emits vapours which may be noxious if inhaled.
Do not use naked flames or create sparks near the open fuel tank or in any other condition where fuel comes into contact with air.

Lubricants

Warning



- The oils used may also be flammable: take the same precautions as those adopted for fuel.

Flammable fluids

Warning



- The fluid in the battery is poisonous and corrosive. Do not let it spill out and come into contact with the skin, eyes or objects.
Do not use naked flames or create sparks near the battery.

Fuel inertia switch

- See page 67.



Warning



Seat belts must be worn at all times and must be properly fastened and adjusted!

Correct use of the seat belts can significantly reduce the risk and severity of injury if an accident occurs or if the vehicle overturns.

Warning



For an effective restraining action, the seat belt must be fastened correctly with the seat backrest in the upright position.

The seat belt is fastened correctly when the upper part of the belt crosses the centre of the shoulder (not the neck) and the abdominal section is fitted over the hips (not the abdomen).

Make sure that the belt is not twisted and that it passes closely over your body; if not, in the event of a head-on collision, it may move and cause injury to the abdomen.

Avoid wearing bulky clothing that may interfere with the proper operation of the seat belts.

Warning



To increase driving safety, it is advisable to position the headrest so that its top is in line with the top of the head.

Warning



Each seat belt has been designed to protect only one occupant. If more than one person uses the same seat belt, the risk of injury in the event of an accident is increased.

Do not sit babies, small children or other persons on your lap.

If there is a collision, the weight of an adult may cause the child to be crushed by the seat belt causing severe or even fatal injuries.

Pregnant women

The best protection for pregnant women and their unborn babies is to wear the seat belt correctly. This significantly reduces the risk of injury to the baby. As a result, pregnant women must always wear a seat belt unless specifically directed otherwise by a medical practitioner. The upper part of the diagonal section of the seat belt must lie snug on the front of the shoulder, pass between the breasts down to the abdomen. The horizontal strap must sit snugly and as far below the abdomen as possible.



Passive safety

The passive safety system has been designed to reduce the risk and severity of injury if an accident occurs.

The vehicle is equipped with the following seat belts:

1. 3-point driver seat belt with pretensioner and load limiter (see page 44);
2. 3-point front passenger seat belt with pretensioner and load limiter (see page 44);

and, only when rear seats are provided:

3. 3-point seat belt in the seat behind the front passenger with pretensioner and load limiting device (see page 47);
4. 3-point seat belt in the seat behind the driver with load limiting device (see page 47)

Warning



Auxiliary safety systems are not a substitute for seat belts. All occupants must always wear a seat belt. Correct use of the seat belts combined with use of the auxiliary safety systems provides optimal protection to the occupants in various types of collisions.

The vehicle also has the following auxiliary occupant protection system components (see page 56 “Auxiliary occupant protection systems”):

5. driver side front airbag (see page 59 for functioning logic);
6. passenger side front airbag (see page 59 for functioning logic);

7. driver side lateral airbag (head bag) (see page 62 for functioning logic);
8. passenger side lateral airbag (head bag) (see page 62 for functioning logic);
9. active roll bars (for operating functions see page 65);
10. seats (see page 193);
11. deformable body;
12. occupant protection system ECU;
13. ECU auxiliary sensors;
14. instrument panel warning light (see page 63);
15. inertia switch.

Only in the presence of rear seats (see also page 50 “Child safety”):

16. a child seat lower anchorage system in the seat behind the front passenger;
17. a child seat lower anchorage system in the seat behind the driver.

The vehicle does not have upper anchorage systems for the installation of child seats.

Warning



The protective action of the airbags is always integrated with the seat belts and the pretensioners. The compulsory use of the seat belt is provided by the national regulations (in Italy, for example, by the Codice della Strada, i.e. Traffic Regulations).



Deformable body

The deformable body absorbs shock and distributes it over the entire structure of the vehicle allowing progressive deceleration.

The passenger compartment structure, on the other hand, has been designed to provide maximum resistance without undergoing deformation in order to guarantee a protective survival cell for the occupants.

Active safety

The aim of the active safety system is to reduce the risk of accidents and injury severity.

The vehicle has been designed to provide a high level of safety for whoever uses it. The following systems are specific active safety components:

- braking system;
- air conditioning and heating system;
- external lights;
- buzzer and warning lights (flashing).

The braking system includes the mechanical brake system and the electronic stability and traction control system (ABS and EBD): this is designed to prevent the wheels from locking and to provide good handling and stability.

In some situations, fast acceleration is important to get out of dangerous situations. However, always use the accelerator with extreme caution. During acceleration of the driving wheels, the anti-skid system may help you in certain dangerous situations.

The air conditioning and heating system in the passenger compartment can add to driving comfort and keep you alert so that you can react quickly when necessary.

It is very important to be able to see the road clearly and be seen and external lights must be turned on when the conditions so require.



Seat belts

Statistics show that when used correctly, seat belts reduce the risk of injury in various types of crashes including the risk of ejection from the vehicle and impact with the interior of the vehicle.

If unfastened, the seat belts do not provide any type of protection. Before every trip, always make sure that all occupants are wearing their seat belts.

Warning



Seat belts must be worn at all times and must be properly fastened and adjusted!

Correct use of the seat belts can reduce the risk of serious injury in the event of an accident or if the vehicle overturns.

Warning



For an effective restraining action, the seat belt must be fastened correctly with the seat backrest in the upright position.

The seat belt is fastened correctly when the upper part of the belt crosses the centre of the shoulder (not the neck) and the abdominal section is fitted over the hips (not the abdomen).

Make sure it is not twisted and that it passes closely over your body; if not, in the event of a head-on collision, it may move and cause injury to the abdomen.

Avoid wearing bulky clothing that may interfere with the proper operation of the seat belts.

The seat belts for the front seats have a lap-shoulder belt with an automatic emergency-locking retractor and are fitted with a pyrotechnic-powered pretensioner and an automatic system that reduces the force applied to the occupant.

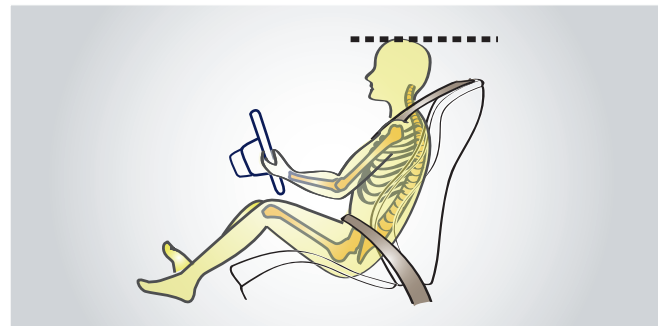



The seat belts for the rear seats have a lap-shoulder belt with an automatic emergency-locking retractor and are fitted with a pyrotechnic-powered pretensioner and an automatic system that reduces the force applied to the occupant.

Warning



To increase driving safety, it is advisable to position the headrest so that its top is in line with the top of the head.

Warning



Do not let the seat belts come into contact with cutting edges. They may get damaged and may consequently break in the event of a collision.

Warning



Each seat belt has been designed to protect only one occupant. If more than one person uses the same seat belt, the risk of injury in the event of an accident is increased.

The seat belt must never be passed around a baby, child or other person sitting on a passenger's lap.

Do not sit babies, small children or other persons on your lap.

If there is a collision, the weight of an adult may cause the child to be crushed by the seat belt causing severe or even fatal injuries.

Warning



Do not attach or pin anything onto the seat belts: they may get damaged and may consequently break in the event of a collision.

Warning



If a seat belt has come into contact with cutting edges or was somehow perforated, we recommend that you have it immediately replaced by the FERRARI SERVICE NETWORK.

Warning



Periodically check the condition of the seat belts. If the belt shows signs of wear, it must be checked by a qualified person and replaced if necessary. Contact the FERRARI SERVICE NETWORK immediately.



How to fasten seat belts

Warning



For an effective restraining action, the seat belt must be fastened correctly with the seat backrest in the upright position.

The seat belt is fastened correctly when the upper part of the belt crosses the centre of the shoulder (not the neck) and the abdominal section is fitted over the hips (not the abdomen).

Make sure it is not twisted and that it passes closely over your body; if not, in the event of a head-on collision, it may move and cause injury to the abdomen.

Avoid wearing bulky clothing that may interfere with the proper operation of the seat belts.

Once you have adjusted the seat correctly (see page 193);

- Grip the latch plate **A**, slowly pull the belt and insert the latch plate into the buckle **B** (if the belt locks while you are pulling it out, let it wind back briefly and pull it out again without jerking).

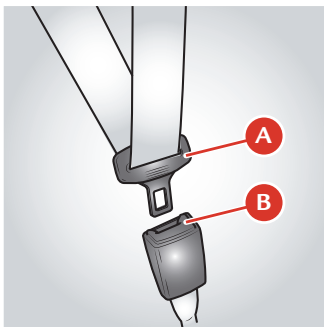

- Make sure that it has clicked into the locked position: hold the belt and pull it to check that the latch plate has been inserted correctly.
- Position the seat belt correctly.

Warning



To position the front seat belt correctly, make sure that it passes through the loop **C**, as shown in the figure.

If the driver's seat belt is not fastened, when you turn the ignition key to position **II**, the warning light **D** on the instrument panel lights up and remains lit until the seat belt is fastened.

55 seconds after a speed of 10 km/h is exceeded, a buzzer sounds warning the driver that the seat belt is not fastened.

When a speed of 20 km/h is exceeded, the buzzer activates immediately and stops after 90 seconds.

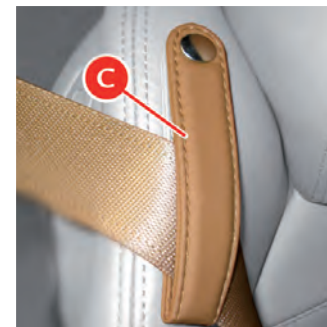



This acoustic signal is emitted only once, even if the vehicle speed goes above and below the above mentioned limits. It is repeated (when the vehicle speed is in the indicated ranges) only if the seat belt is fastened and unfastened again or, in any case, every time the engine is turned off and then on.

Warning



Each seat belt has been designed to protect only one occupant. If more than one person uses the same seat belt, the risk of injury in the event of an accident is increased.

The seat belt must never be passed around a baby, child or other person sitting on a passenger's lap.

Do not sit babies, small children or other persons on your lap. If there is a collision, the weight of an adult may cause the child to be crushed by the seat belt causing severe or even fatal injuries.

Unfastening the seat belts

- Push the release button **E**.
- Guide the latch plate **A** back to its rest position.

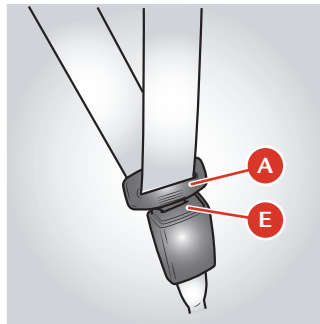
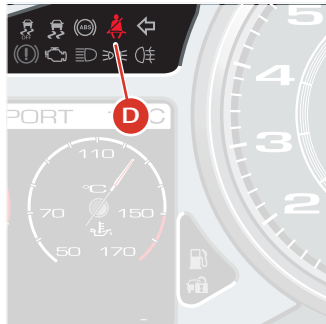

Use of rear seat belts

Warning



Only persons who are **less than 1.50 m tall** may travel in the rear seats.

The minimum distance between the head of the rear passenger when seated correctly and the rear window must be at least 2.5 cm.

Any taller person travelling in the rear seat risks serious injury in the event of an accident.

Any taller person travelling in the rear seat risks serious injury if the retractable hard top is opened or closed.

Warning



The retractable hard top **MUST** only be operated when no persons and/or children are occupying the rear seats.

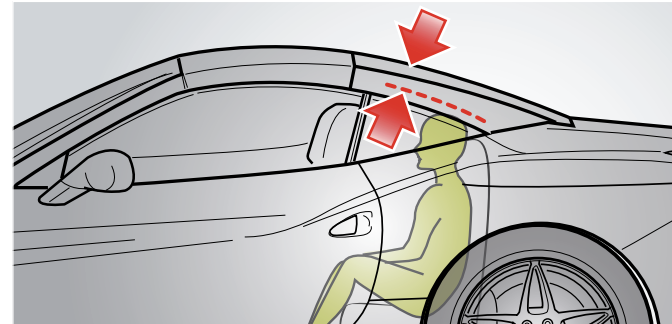



The rear seat belts must be fastened as shown in the diagram.

Warning



Remember that, in the event of a violent impact, passengers in the rear seats who are not wearing seat belts are not only subject to personal injuries (they can be projected forward, hit the windscreen and be thrown out of the vehicle) but also constitute a danger to the passengers in the front seats.

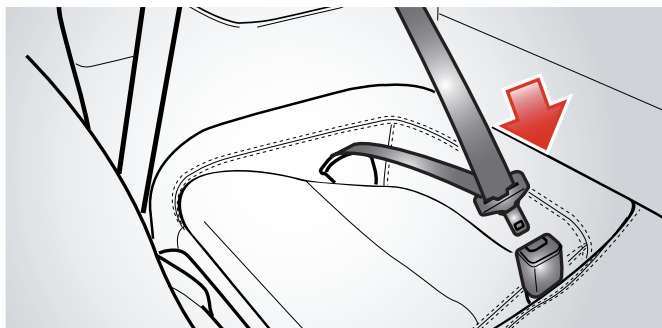

Pretensioners

The seat belts for the front seats are fitted with pyrotechnic-powered pretensioners. The pretensioner is activated by the airbag ECU when there is a sufficiently severe head-on collision (impact direction between 11 and 1 o'clock p.m.) or a sufficiently severe side collision. The pretensioner is also activated when there is a sufficiently severe rear collision or a roll-over. The belt will rewind a few centimetres just before the restraining action begins, thereby improving the fitting across the occupant's body.

Activation of a pretensioner is signalled by the illumination of the warning light **A** on the instrument panel.

Warning



Pretensioners that have been activated will no longer function and may not be repaired under any circumstances. Contact the **FERRARI SERVICE NETWORK** for replacement.

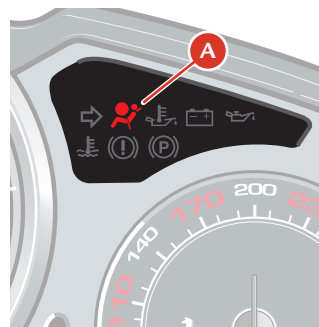



When a pretensioner is activated, a small amount of smoke is released. This smoke is not harmful.

Warning



Activation of the pretensioners only depends on the status of the seat belts and is not affected by the occupants' presence.

If the seat belt is not fastened, the pretensioner will not activate, even if the seat is occupied.

The seat belts for the front seats and any rear seats are fitted with a load limiting device. The load limiting device is located in the belt winder and allows controlled release of the belt during a collision thereby limiting the impact that the belt has on the occupant's body.

Maintenance of seat belts and pretensioners

- Following a serious collision, replace the seat belts that were worn at the time even if they do not appear to be damaged.
- Periodically check that the screws on the anchor points are tight and that the seat belt is in perfect condition and slides smoothly.
- The seat belt must be kept clean; the presence of any dirt could prevent the seat belt retractor from working properly.
- To clean the seat belt, wash it by hand with mild soap and water and let it dry. Do not use strong detergents, bleach or aggressive solvents, as they can weaken the fibres.

Make sure the retractors do not get wet: proper functioning is only ensured if they are kept dry.

- The pretensioner requires no maintenance or lubrication.

If immersed in water or mud, it must be replaced.

- Pretensioners must be replaced at regular intervals as indicated in the "Warranty Booklet".

Important note



All work on any part of this safety system must be performed by the FERRARI SERVICE NETWORK.

Warning



Removing or making modifications of any kind to the seat belts, belt retractors and pretensioners is not allowed.

Maintenance work involving strong impacts, vibrations or heating of the pretensioner area may activate them; vibrations caused by road bumps will not have this effect.



Child safety

Warning



Never leave children ALONE and/or unattended in the vehicle since this may constitute a danger to themselves and others.

In many countries, the transportation in vehicles of children and infants is governed by specific legislation.

Drivers are obliged to comply with applicable regulations.

Warning



If we use a risk assessment matrix that combines the likelihood of an event occurring and its consequences, we can see that a child in a child seat on the front seat presents a serious risk and the responsibility of the driver is therefore high. All possible precautions should be taken.

Even in latest generation vehicles, statistics show that the rear seats are the safest position for transporting babies and children.

Warning



Drive slowly and pay maximum care and attention when transporting children. Sudden acceleration caused by sports-style driving may be dangerous for children even if no collision occurs.

Warning



The instructions in this Owner's Manual ONLY apply to the seats shown in the figures below.





Warning



Do not transport young children in rearward facing child restraint systems on the front passenger seat.

Because of their size, children are at greater risk than adults. Suitable child restraint or safety systems must therefore be used and seat belts should only be used to secure the child seats.

All minors whose physical characteristics (i.e. height, weight) fall within the legal limits in force in each country must be protected by approved restraint or safety systems (e.g. child seats, cradles, cushions).

You are therefore advised to **ALWAYS** use homologated child restraint systems that bear the proper test marking. Child seats approved according to the ECE-R 44 standard bear this alphanumeric code (a letter “E” in a circle with the approval number underneath) followed by the name of the group (e.g. Group 2).

Warning



Incorrect fastening of a child restraint system increases the risk of injury to the child if an accident occurs.

The seat belts on a vehicle have been designed and tested to protect persons who are over 1.50 m tall.

To properly protect children outside these limits, specific restraint systems with dedicated belts or accessories capable of adapting the child’s position to the vehicle seat belts must be fitted.

Warning



For installation and use (how to secure the child to the restraint system) of child restraint systems, follow the instructions that the manufacturer of the devices is obliged to provide.

Warning



Carefully follow the instructions provided with the child seat: keep them in the vehicle together with the documents and this manual. Do not use second-hand child seats with no instructions.

Warning



Follow the instructions given by the child restraint system manufacturer when choosing, installing, positioning (forward/rear facing) and using the restraint system since failure to do so may compromise its protective action.



Warning



Always check the seat belts have been securely fastened by pulling on the seat belt.

Warning



After an accident, have all the parts of the child restraint system and vehicle seat belt system checked and replace them if necessary.

Any work must be performed at the **FERRARI SERVICE NETWORK**.

Children must always be transported in restraint systems that are suitable for their size.

Before choosing a child restraint system, always check that:

- it is homologated. The homologation standard is ECE-R 44 (a letter "E" in a circle with the approval number underneath) followed by the name of the group (e.g. Group 2);
- it is suitable for the height and weight of the child to be transported (**CAREFULLY FOLLOW** the instructions in the child restraint system use and maintenance manual);
- it can be securely installed in the vehicle in compliance with the child restraint system manufacturer's instructions;
- the use and installation instructions are easy to understand.

Warning



If violent braking or a collision occurs, children who are not in a restraint system can be thrown against the dashboard or the windscreen: this may lead to serious or even fatal injury to the child.

Warning



Never allow children to travel sitting in the lap of an adult. If there is a collision, the adult's weight may crush the child against the seat belt, the dashboard or the back of the front seat: this may lead to serious or even fatal injury to the child.

Important note



NO modifications MUST be made to the seat belts and child restraint systems: any modifications may seriously jeopardise the safety of the child restraint system.

Front passenger seat

The front passenger seat does not have ISOFIX hooks for child restraint systems.

Secure the child restraint system to the vehicle seat using the seat belt and make sure you have activated the automatic belt winding locking system before installing the child seat in the vehicle.

To activate the automatic belt winding locking system, pull the seat belt until the belt completely unwinds. At this point, the belt retractor will only allow the seat belt to rewind.



The fact that the belt cannot be pulled out confirms that the belt locking system has been activated.

To deactivate the locking system, unfasten the seat belt in order to allow it to rewind completely.

Warning



Each time the belt is used to fasten a normal occupant, the automatic belt winding locking system will have to be deactivated.

Warning



ALWAYS COMPLY with the legal requirements in force in your own country: restrictions on the use of seat belts are applied according to age (up to 12 years old) and height (up to 1.50 m).

Important note



For child restraint systems that can be installed on the front passenger seat with 3-point seat belts, see **TAB. 1** on page 77.



Rear seats

Statistics show that the rear seats are the safest position for transporting babies and children.

Warning



Before installing a child restraint system on the rear seats, the corresponding front seat must first be positioned as far forward as possible with the backrest as upright as possible.

Warning



The retractable hard top **MUST** only be operated when no persons and/or children are occupying the rear seats.

Warning



Before operating the retractable hard top, make sure that the backrest of the child restraint system is set to its minimum height.

Warning



If violent braking or a collision occurs, children who are not travelling in a restraint system can be thrown against the dashboard, windscreen or front seats: this may lead to serious or even fatal injury to the child.

Warning



Never allow children to travel sitting in the lap of an adult. If there is a collision, the adult's weight may crush the child against the seat belt, the dashboard or the back of the front seat: this may lead to serious or even fatal injury to the child

To transport a child on the rear seats, use the seat belts to secure the child restraint system to the vehicle seat and make sure you have activated the automatic belt winding locking system before installing the child seat in the vehicle.

To activate the automatic belt winding locking system, pull the seat belt until the belt completely unwinds. At this point, the belt retractor will only allow the seat belt to rewind.

The fact that the belt cannot be pulled out confirms that the belt locking system has been activated.

To deactivate the locking system, unfasten the seat belt in order to allow it to rewind completely.

Warning



Each time the belt is used to fasten a normal occupant, the automatic belt winding locking system will have to be deactivated.



Both rear seats are fitted with an ISOFIX fastening system consisting of two lower anchor points (marked **A** in the figure).
The lower anchor points **A** are located between the seat cushion and the back of the rear seats under the special leather cover. The anchor points are marked with a special symbol so that they can be easily found.
The vehicle has no upper anchorage systems.

Important note



For child restraint systems that can be installed on the rear seats with 3-point seat belts and the ISOFIX system respectively, see **TAB 2.**, **TAB 3.** and **TAB 4.** on pages 78-79.

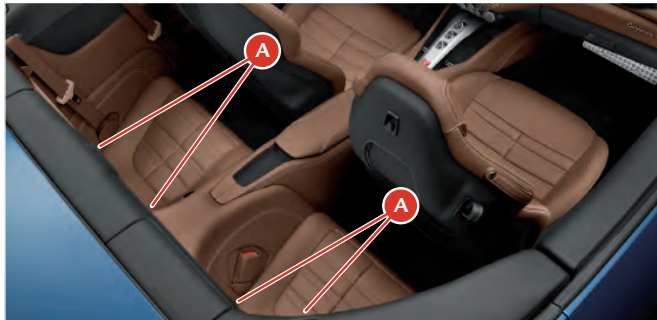



Auxiliary Occupant Protection Systems (driver and passengers)

Warning



Auxiliary Occupant Protection Systems are not a substitute for seat belts but increase their efficiency. Correct use of the seat belts, with the supplementary action of the Auxiliary Occupant Protection Systems, offers maximum protection in the event of a head-on collision or vehicle roll-over.

Auxiliary Occupant Protection System components (driver and passengers)

The Auxiliary Occupant Protection System components are:

1. Seat with built-in headrest and belt loop.
2. Dual-stage front driver's airbag.
3. Dual-stage front passenger airbag.
4. Driver's head protection side airbag (head bag).
5. Passenger head protection side airbag (head bag).
6. Driver's seat belt (3-point with pretensioner and an automatic system that reduces the force applied to the occupant).
7. Front passenger seat belt (3-point with pretensioner and an automatic system that reduces the force applied to the occupant).
8. Rear seat passenger seat belt (3-point with automatic system that reduces the force applied to the occupant).
9. Rear seat passenger seat belt (3-point with automatic system that reduces the force applied to the occupant).
10. Active roll bars.
11. Electronic Control Unit (ECU).
12. Additional sensors.
13. Instrument panel warning light.
14. Deformable body.



The airbags **2** and **3** have been designed to increase the level of protection given by the seat belts in the event of a head-on collision (see page 58).

The airbags **4** and **5** have been designed to increase the level of protection given by the seat belts in the event of a side collision and are placed between the occupant's head and external structures which could go through the passenger compartment and cause injury (see page 62).

The roll bars **10** have been designed to help maintain a survival area in the event of a roll-over (see pages 65-67).

Since it is impossible to gauge vehicle dynamics and movements of the occupants in an accident, the active roll bars are also activated as a precautionary measure in the event of:

- sufficiently severe head-on collisions (that activate the front airbags) if they have caused a cut-out of the fuel supply;
- sufficiently severe side or rear collisions.

Warning



The warning light **A** (see page 48) comes on when the ignition key is turned to position **II**. If no malfunctions are detected, it goes out after approximately 4 seconds. If the warning light does not come on, if it remains on or if it comes on while driving, contact the **FERRARI SERVICE NETWORK** immediately.

2



Driver and passenger airbags

Warning



The front airbags do not provide protection in the event of side-on collisions, some head-on/angular collisions, roll-overs or subsequent collisions (if there is a second collision once the airbags have been deployed in an earlier collision). The seat belts have been designed to reduce the risk of injury in the event of a roll-over or subsequent collision.

Warning



The front airbags have been designed not to inflate if a minor collision occurs. The seat belts have been designed to reduce the risk of injury if a minor collision occurs.

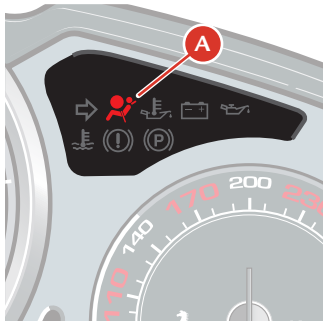

Warning



The driver and the passenger must maintain a distance of at least 25 cm from the steering wheel and the dashboard.

Always drive with your hands on the rim of the steering wheel so that in the event of activation, the airbag can deploy without obstruction.

Driving with your hands on the steering wheel spokes or on the airbag cover increases the risk of injury for your wrists and arms.

Warning



The front passenger must be seated correctly: never put your hands, feet or legs on the dashboard since if the front airbag is activated, it may cause injury to your legs and prevent the airbag from working properly.

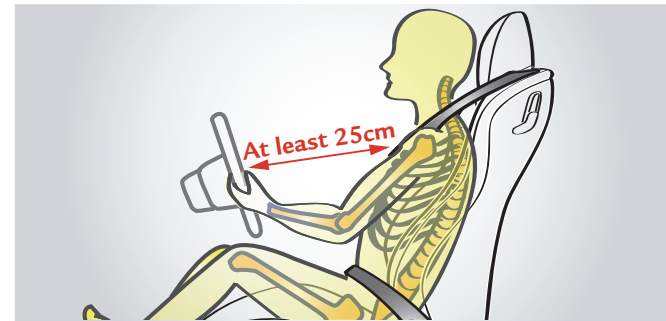



Operation

The front airbags are controlled by an ECU which activates them when there is a sufficiently severe head-on collision (direction of impact between 11 and 1 o'clock p.m.).

In the event of a collision with an impact force that causes deceleration that exceeds the value set for the internal sensor, the ECU will transmit a signal to deploy the airbags. The airbags will begin to inflate, breaking the cover along the breakage line and will deploy completely in a few tenths of milliseconds. Once deployed, they will serve as protection between the driver and/or passenger and structures that could cause injury.

The airbags deflate immediately afterwards.

Important note



If a head-on collision occurs that causes a cut-out of the fuel supply, the active roll bars will also be activated as a precautionary measure.

Warning



The driver and passenger should not carry objects (drink cans or bottles, pipes, etc.) that may cause injury if the airbags are activated.

Persons, animals or items must not be placed between the airbags and the occupant.

Environment



When the system is activated, gases are released in the form of fumes, together with the gas used for inflating the airbags. These gases are not harmful.

The driver's airbag has been designed to be deployed according to the following strategy:

- For low severity crashes, the airbag control unit will not deploy the airbag.
- For crashes of higher severity, the control unit will deploy the driver airbag in low energy mode.
- For crashes of even higher severity, the control unit will deploy the driver airbag in high energy mode.

The passenger airbag has been designed to be deployed according to the following strategy:

- For low severity crashes, the airbag control unit will not deploy the airbag.
- For crashes of higher severity, the control unit will deploy the passenger airbag in low energy mode.
- For crashes of even higher severity, the control unit will deploy the passenger airbag in high energy mode.

Warning



Even in vehicles with Advanced Airbag Systems, according to statistics, the rear seats are the safest position for transporting babies and children.

Children must always be transported on the rear seats if the vehicle is equipped with them.

Warning



The driver and passenger must always fasten their seat belts and sit in an upright position, as far as possible away from the airbag, in order to have optimal protection in all types of collision.



Warning



Always keep the backrest of your seat in the upright position and sit with your back properly resting against it.

Important note



Do not modify the system components or wiring, under any circumstances.

With the ignition key inserted and in position II, although the engine is off, the airbags can still be activated when the vehicle is stationary if it is hit by a moving vehicle.

Remember that if the ignition key is set to 0 none of the safety devices (airbags or pretensioners) is activated in the event of a collision; failure of the airbags to inflate in these circumstances is not indicative of a system malfunction.



Important note



Do not cut or tamper with the connectors of the airbag harness or on the airbag modules.

Warning



Do not cover the steering wheel and the padded panel on the dashboard on the passenger's side with adhesive tape or treat it in any way.

Warning



Do not place objects above or near the top of the dashboard and the steering wheel.

In the event that the airbags are deployed, these objects would be projected into the passenger compartment at a high speed that would seriously jeopardise the safety of the occupants.

Warning



Do not modify the airbag modules in any way (indicated in the relevant picture). Do not damage the airbag modules (for example pinning something onto them or pressing objects against their covers).

If, for any reason, an airbag cover gets damaged, have the airbag module immediately checked by the **FERRARI SERVICE NETWORK**.

Activation of a damaged module could cause serious or fatal injuries.



Important note



Do not remove or dismantle parts of the steering wheel, dashboard or door panels. If necessary, this procedure should only be performed by a FERRARI SERVICE NETWORK CENTRE.

Important note



All the airbag system components must be replaced after an accident that caused airbag deployment.

Important note



Following an accident not involving airbag deployment, contact the FERRARI SERVICE NETWORK to have the system checked and any system components that may be damaged or malfunctioning replaced.

Important note



The airbag system components have been specially designed only for this specific vehicle model. Do not use them on a different vehicle model, as this may cause serious damage and consequent injury, even fatal, to the occupants in the event of an accident.

Warning



Damaged or defective components of the airbag system cannot be repaired and must be replaced.

Improper operations performed on the system components may cause failures or accidental deployment or failure of the airbags to inflate with consequent damage and injury, even fatal.

Environment



To scrap the vehicle, please contact the FERRARI SERVICE NETWORK to have the airbag system deactivated.

2



Important note



If the vehicle has been stolen or there has been an attempted theft, have the airbag system checked by the **FERRARI SERVICE NETWORK**.

The label **F** indicates the presence of the airbag system.



Side airbags

Warning



Airbags are not a substitute for seat belts but they increase their efficiency. Correct use of seat belts, with the supplementary action of the side airbags, offers maximum protection in the event of a collision or vehicle roll-over.

Side airbag system components

Warning



The side airbags fitted on the vehicle have not been designed to reduce the risk of being thrown out in the event of vehicle roll-overs.

The vehicle has 2 side airbags, one in the driver-side door panel and the other in the passenger-side door panel.





The side airbag system consists of 2 airbags, one on each door. In the event of a side collision, the airbag on the impact side deploys immediately to protect the occupant's head.

Warning



When the ignition key is turned to position **II**, the warning light **B** will come on. If no malfunctioning in the airbag system is detected, it will go off after 4 seconds. If the warning light does not come on, if it remains on or if it comes on while driving, contact the FERRARI SERVICE NETWORK immediately.

Operation

The side airbags are controlled by the ECU that activates them when a sufficiently severe collision occurs.

In the event of a side collision with a force of impact exceeding the limit set by the ECU, this will transmit a signal that activates the pretensioner, the head bag on the impact side and the active roll bars (precautionary measure because of possible deformation

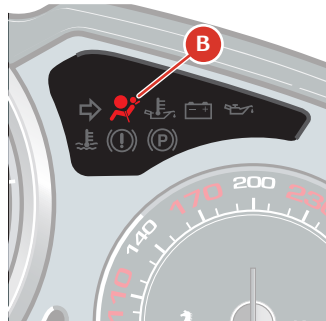

of the vehicle body that may affect deployment if there is a subsequent roll-over.

The airbag will start inflating, opening its cover along the breaking line, until it is fully deployed (in a few hundredths of seconds). After deployment, the head bag will act as a protection between the driver's or passenger's head and the external structures which could go through the passenger compartment and cause injury. The airbags deflate immediately afterwards.

Side airbag activation is not affected by the front passenger's height or weight. The side bag is activated whenever the airbag ECU detects a collision of a sufficient impact force for deployment.

Warning



Never drive with your head out of the window as this places your head and neck in the airbag deployment area. In the event of a side-on collision, this position increases the risk of being thrown out of the vehicle and compromises the protective action of the head bags.

Warning



Never place an object over or near the airbag covers. In the event that the airbags are deployed, these objects would be projected into the passenger compartment at such high speed as to seriously jeopardise the safety of the occupants.



Warning



Never modify the airbag modules. Do not damage the airbag modules or the trim panels covering (upper area of door panel), by pinning objects onto them or pressing objects against their respective covers, for example.

If, for any reason, an airbag cover gets damaged, have the airbag module immediately checked by the FERRARI SERVICE NETWORK. Activation of a damaged module could cause serious injuries.

Important note



Please consider that the airbag ECU is not capable of automatically detecting damages involving the airbag covers.

Do not cover the upper part of the driver-door and passenger-door panels with adhesive tape or material and do not treat them in any way.

Warning



After deployment, the airbag components can no longer offer any protection; therefore, they cannot be repaired and must be replaced. After activation of a head bag, have it replaced by the FERRARI SERVICE NETWORK.

Warning



The airbag modules are subject to wear and tear and must be replaced at the intervals indicated in the “Warranty Booklet” EVEN if the vehicle has NOT been involved in a collision.

Important note



Never remove the door panel. If required, this operation must be performed by the FERRARI SERVICE NETWORK.



Roll bar

The active (ejectable dynamic) roll bar has been designed and installed to maintain the survival area of the occupants in the event of a vehicle roll-over.

The active roll bars are controlled by the ECU that activates them when there is a strong roll around the longitudinal axis of the vehicle and there is a risk of vehicle roll-over.

In the case of a roll that exceeds the calibration thresholds, the ECU will release the roll bar locking system and deploy the roll bars in a few tenths of a second. Once deployed, the active roll bars help to maintain an occupant survival area together with the windscreen bay (and the hard top if used).

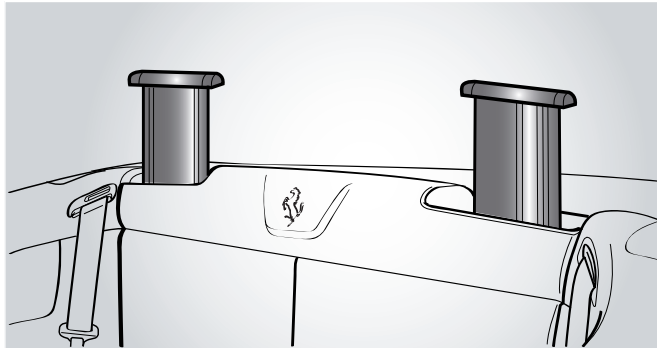

Warning



The active roll bars do not reduce the risk of ejection of any occupants who are not wearing their seat belts or the risk of injury caused by impact with the interior of the vehicle in the event of a collision or roll-over.

The seat belts must always be fastened to reduce the risk of being thrown out of the vehicle and reduce the risk of injury caused by impact with the interior of the vehicle.

Important note



The active roll bars are also deployed in the event of a sufficiently severe rear or side collision as a precautionary measure against subsequent roll-over of the vehicle.

Since it is impossible to gauge vehicle dynamics and movements of the occupants in an accident, the active roll bars are also activated as a precautionary measure in the event of:

- sufficiently severe head-on collisions (that activate the front airbags) if they have caused a cut-out of the fuel supply;
- sufficiently severe side or rear collisions.



Important note



The active roll bars are not deployed in the event of a roll-over around a transverse axis (Y axis in the figure).

Warning



Do not travel with rear occupants resting their heads on the roll bar covers, facing rearward or seated on top of the roll bar covers.

If activated, the roll bars will increase the risk of injury.

Warning



Never place objects over or near the roll bar covers. If the roll bar is activated, they may delay or prevent its ejection. They could also be projected into the passenger compartment at such high speed as to seriously jeopardise the safety of the occupants.

Warning



If activated, the roll bar must be replaced. Contact the **FERRARI SERVICE NETWORK**.

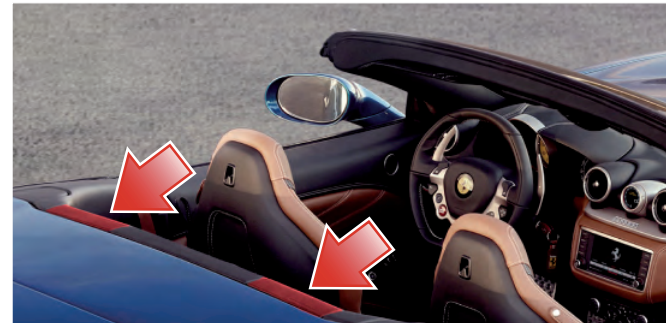



Warning



The roll bar is a pyrotechnic-powered system.
The system cannot be repaired.
Risk of injury if accidentally activated.
Each operation must only be performed by authorised staff.
Contact the **FERRARI SERVICE NETWORK**.

Warning



Never modify the roll bar modules. Do not damage the roll bar module covers (for example pinning something onto them or pressing objects against their covers).
If, for any reason, a roll bar cover gets damaged, have the roll bar module immediately checked by the **FERRARI SERVICE NETWORK**.
Activation of a damaged roll bar module could cause serious or fatal injuries.

Warning



The roll bar modules are subject to wear and tear and must be replaced at the intervals indicated in the “Warranty Booklet” even if the vehicle has NOT been involved in a collision.

Fuel inertia switch

This is a safety switch **A** located in the passenger compartment, on the floor in front of the driver seat, which deactivates the fuel pump relays if a collision occurs.

A symbol on the TFT display and the hazard warning lights come on to indicate that the switch has been activated.

When activated, the doors are also unlocked (if locked) and the central dome light comes on.

2

Warning



The system can be reactivated by pressing the button on the top of the switch.

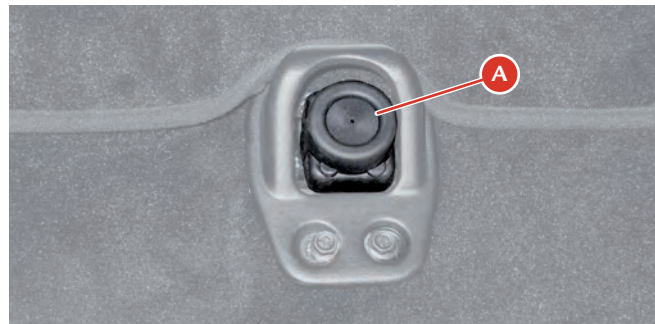



ABS and EBD

This is a safety device which activates to prevent wheel locking if the driver depresses the brake pedal too sharply, especially under poor grip conditions.

The system is composed of:

- electro-hydraulic unit;
- electronic brake-force distribution **EBD**;
- four speed sensors on the wheels, incorporated in the bearings;
- the entire ESP sensor system (steering angle sensor, accelerometer, yaw sensor, etc.).

These features add to the vehicle's standard braking system, without changing its characteristics.

Important note



When the **ABS** system is active, during emergency braking or in poor grip conditions, a “pulsing” sensation will be felt through the brake pedal. Hold the brake pedal down to continue the braking action.

When one of the wheels starts locking, the hydraulic control unit controls the braking circuit by running a 3-phase cycle:

- reduction (if necessary);
- maintenance;
- pressure increase in the hydraulic circuit.

In the event of **ABS** activation under braking, these regulation cycles will be repeated until the car comes to a stop or pressure on the brake pedal is reduced.

In addition, the system offers the following advantages:

- Driving stability (no skidding): even in the event of sharp braking approaching wheel locking.
- Manoeuvrability (no side-skidding on sharp turns).

This means that even when an emergency situation requires sudden braking, the driver can avoid obstacles, or brake on a curve, without affecting the vehicle stability.

Warning



The **ABS** system features remain unaltered as long as the speed limit for the tyre side grip is not exceeded. When this limit is exceeded, vehicle skidding cannot be avoided.

- Optimal braking distance:
depending on the type of road surface, the braking distance may be reduced by as much as 40%.

Warning



The **ABS** system does **NOT** exempt the driver from driving carefully and responsibly at all times.



Important note



The **ABS** system improves braking distances in all conditions, but cannot compensate for the driver's failure to maintain safety distances or loss of control in poor road conditions.

The purpose of the ABS system is to maximise the efficacy of the brake system in all situations, and, in particular, at the limit of grip of the tyres and in changing road surface conditions.

ESC - Stability and Traction Control

The electronic stability control ESC consists of two main systems:

VDC Vehicle Dynamics Control, performed through the braking system

F1-Trac traction control, performed through engine torque modulation, depending on maximum grip on the road and secondary systems that are always active such as the **ABS** and **EBD**.

To provide optimal control in different driving and grip conditions, three different setting levels have been designed:

- **Level 1:** ensures stability and maximises traction on every type of road surface, both in low (Manettino set to **Comfort**) and very low grip conditions, by means of engine and brake control (in this condition, the standard **ASR** system activates instead of the **F1-Trac** function).
- **Level 2:** ensures stability and maximises traction only in medium- to high-grip conditions (Manettino set to **SPORT**) optimising engine and brake control.

- **Level 3:** ESC deactivated (Manettino set to **ESC OFF**). Stability is not ensured, but all the other features always present in the other settings, such as the **ABS** and **EBD**, remain active. The **VDC** system remains active under braking.

F1-Trac

F1-Trac is directly derived from FERRARI's expertise in F1 vehicles. This system optimises traction by controlling engine power delivery.

F1-Trac is faster and more accurate than the traditional control systems, and is capable of delaying and minimising engine torque adjustments as required, in order to ensure the desired trajectory.

The system estimates the maximum available grip in advance, by continuously monitoring the relative wheel speed and using an auto-adaptive operating logic. Comparing this information with the vehicle dynamics model stored in the control system, **F1-Trac** optimises the vehicle behaviour by controlling engine torque delivery.

Important note



F1-Trac does not work when the Manettino is set to the ESC OFF driving mode.



EPB - Electric parking brake

On this vehicle the parking brake is actuated by an electric motor.

The parking brake can be applied and released by pulling a special lever **A** on the dashboard to the left of the steering wheel. With the ignition key turned to **II**, the relative indicator on the instrument panel (see page 152) lights up to indicate when the parking brake is engaged.

To release the parking brake, pull lever **A** and keep the brake pedal pressed. If the ignition key is in position **II**, the warning light will go out when the parking brake has been fully released.

The electric parking brake can be used as an emergency brake when the vehicle is in motion. If this is the case, the system acts on all four wheels until button **A** is released by communicating with the ESP system which prevents locking.

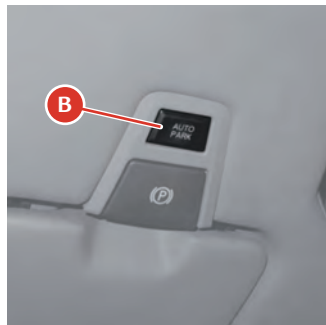
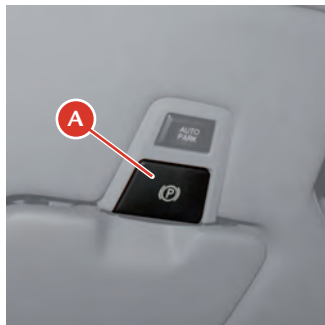

Warning



Always apply the parking brake when the vehicle is parked.
The vehicle should be blocked. If this is not the case, please contact the **FERRARI SERVICE NETWORK**.

Autopark Function

The EPB Autopark function automatically activates the electric parking brake when the engine is switched off. At each Key-on, the Autopark function is always active by default: this means that the driver does not need to apply the parking brake when the engine is switched off.

However, the function can be temporarily deactivated before switching off the engine by pressing the **AUTO PARK B** button: the message “PARK OFF” is displayed on the TFT display for 5 seconds. If this is the case, the parking brake should be manually applied by pulling lever **A** once the engine has been switched off. To re-enable automatic EPB engagement at the next key-off, press button **B** again; the message “PARK ON” is displayed on the TFT display for 5 seconds.

“Automatic Vehicle Holding” AVH function

The electric parking brake provides optimised release when the vehicle starts up due to its Automatic Vehicle Holding function: once the engine has started, the system keeps the vehicle braked through intervention of the braking system rather than through the parking brake shoes.

For further information, refer to pages 183-184.



Tyre temperature and pressure monitoring system (TPMS)

The vehicle is equipped with a system that measures the tyre pressure and temperature using special sensors fitted inside the wheel rims next to the air valve. These sensors transmit a signal that is received by the antennas on the car body, behind the gravel guards, that are connected to the ECU.

Important note



The system may be affected by radioelectrical interference from devices that use similar wavelengths.

The ECU processes this information and transmits data on tyre pressure and temperature and any system errors to the instrument panel.

The signal transmitted by the ECU activates symbols on TFT display (see page 151) with two priority levels: a **soft warning** (sw) if the pressure loss compared with the nominal pressure **exceeds 0.2 bar** and a **hard warning** (hw) if it **exceeds 0.5 bar** or there is a dynamic loss of over 0.2 bar/min.

The system can be calibrated using the special menu item in the TFT display (see page 132).

Important note



System calibration using the special menu item on the TFT display is necessary after replacement or inflation of a tyre or tyres.

Warning



The TPMS warns the driver that the tyre pressure has decreased. However, this does **NOT** exempt the driver from periodically checking with a pressure gauge that the tyres are inflated to the indicated pressure.

The system does **NOT** warn the driver of damage to the tyres by external agents.

2

Display of messages on the TFT display

By using the commands on the left TFT display (see page 130), the driver can access the **TYRES** screen page which displays the vehicle symbol with the pressure and temperature values of each tyre as shown in example 1.

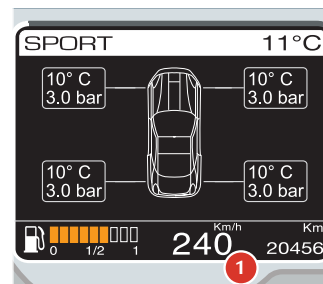



If an event occurs that needs to be viewed when the **TYRES** screen page is being displayed, the screen is displayed in reduced size as in the following example **2**:

Once it has been displayed, the **TYRES** screen page is displayed again. For further information, refer to the “Fault visualisation logic” paragraph on page 146.

Low pressure

Regardless of the type of screen page on the left TFT display, when the instrument panel receives the signal from the tyre pressure ECU that the pressure level of one or more tyres is below the alarm threshold, the screen page shown in example **3** (for a warning related to only one tyre) or example **4** (for a warning related to several tyres) appears immediately.

The screen page is displayed for 20 seconds and then the screen page that was previously displayed reappears. If the failure persists, the screen page shown above (example **3** or **4**) will be automatically displayed for 20 seconds the next time the engine is started.

The driver can call up the **TYRES** screen page at any time to display which tyres have low pressure (example **5**).

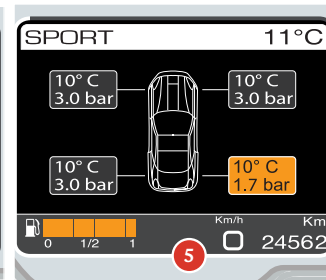
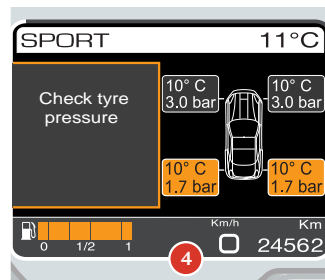
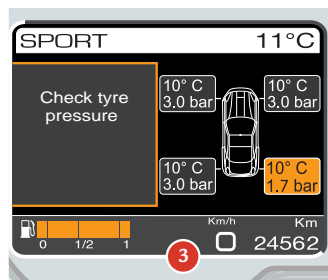
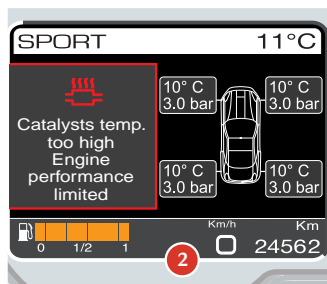



Occasionally, the system may not detect which wheel signals a failure. If this is the case, then only the message “Check tyre pressure” will be displayed as shown in example 6.

Tyre puncture

Regardless of the type of screen page on the left TFT display, when the instrument panel receives the signal from the tyre pressure ECU that the pressure level of one or more tyres is below the alarm threshold, the screen page shown in example 7 (warning not to proceed for vehicles fitted with normal tyres) or example 8 (warning to proceed at a maximum speed of 80 km/h for vehicles fitted with Run Flat tyres) appears immediately. At the same time, a warning light comes on on the panel (see page 151) in fixed mode.

The screen page is displayed for 20 seconds and then the screen page that was previously displayed reappears whereas the warning light remains on in fixed mode.

If the vehicle is fitted with normal tyres, the fault is displayed with the same display logic applicable for other priority 0 faults (see the paragraph “Fault visualisation logic” on page 146) until the correct operating conditions are restored and the system is subsequently recalibrated.

If the vehicle is fitted with Run Flat tyres, the maximum distance allowed in a “tyre puncture” state is 100 km. The instrument panel will calculate the residual tyre life and will redisplay the screen page shown in example 8 after 50 km. The same screen page (warning not to exceed a maximum speed of 80 km/h) is displayed if the vehicle exceeds 80 km/h.

Once the distance of 100 km has been exceeded, the panel displays the screen page shown in example 7 (warning not to proceed).

If you call up the TYRES screen page, you can identify the punctured tyre at any time (example 9).

2

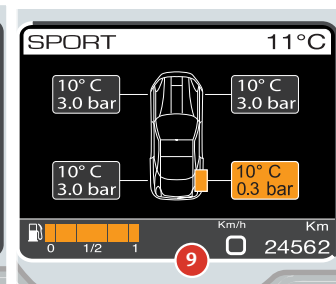
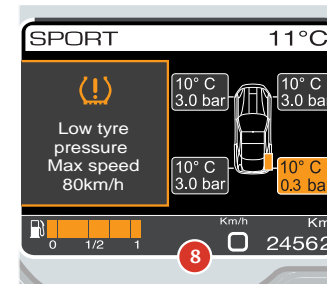
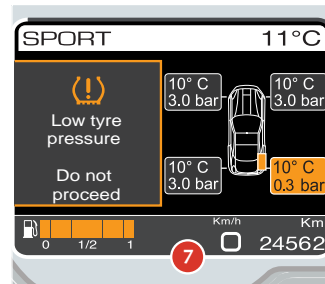
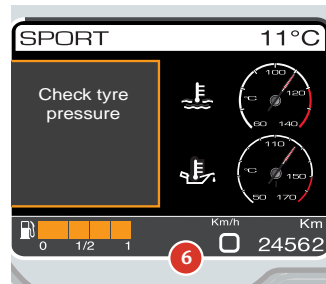



If another tyre is punctured, the instrument panel will update the number of km (mi) which can still be driven according to the distance driven after the previous puncture and will display the screen page shown in example 10.

While a priority level 0 (normal tyre puncture) or priority level 2 (Run Flat tyre puncture with maximum speed limit not exceeded and tyres still usable) fault is active on the display, the driver may press **OK** to “ESCAPE” (see page 146): the screen page disappears whereas the warning light on the panel remains on in fixed mode.

As above, the TYRES screen page can be called up at any time to display which tyres are punctured (example 11).

Occasionally, the system may not detect which wheel signals a failure. If this is the case, the screen page shown in example 12 (for vehicles fitted with normal tyres) or example 13 (for vehicles fitted with Run Flat tyres) will be displayed.

The symbol and message are displayed for 20 seconds and then the screen page that was previously displayed reappears whereas the warning light remains on in fixed mode.

If the vehicle is fitted with Run Flat tyres, the instrument panel will calculate the residual tyre life and will redisplay the screen page shown in example 13 after 50 km. The same screen page (warning not to exceed a maximum speed of 80 km/h) is displayed if the vehicle exceeds 80 km/h. Once the distance of 100 km has been exceeded, the panel displays the screen page shown in example 12 (warning not to proceed).

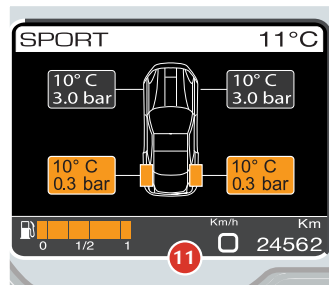
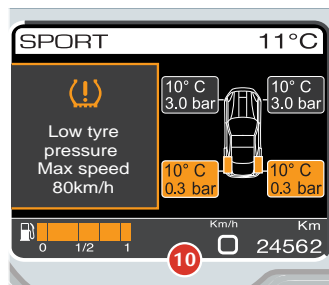



System not calibrated

If the system has not been calibrated or one or more tyres have been replaced, the symbol and message shown in example 14 will be displayed. Simultaneously, the specific warning light on the instrument panel (see page 151) starts flashing, and continues to flash for 90 seconds.

When the display cycle ends (20 seconds), the symbol and message disappear and the screen page that was previously displayed reappears whereas the warning light remains on until the system has been calibrated.

The TPMS can be calibrated using the special menu item in the left TFT display with the ignition key in position II and the engine off.

To calibrate the TPMS, call up the MENU screen page on the left TFT display (see page 132) with the ignition key in position II and the engine off. Once the MENU screen page appears, select the items “Car setup”, “Calibr. TPMS”.

When the Menu item is displayed and the subsequent calibration accepted, the screen page shown in example 15 appears for 5 seconds.

Warning



Before calibrating the system, make sure that the tyre pressure corresponds to the indicated pressure values (see page 30). If this is not the case, the TPMS may issue wrong low pressure indications.

2

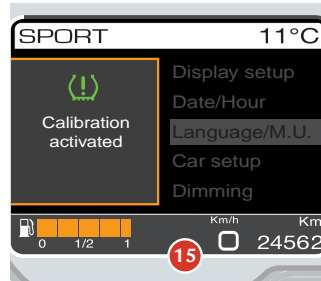
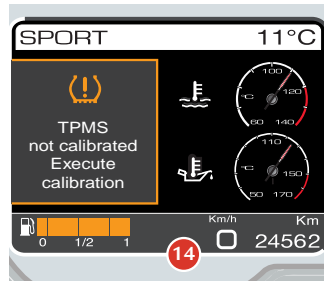



TPMS failure

The screen page shown in example 16 is displayed in the following circumstances:

- malfunction in the circuit and/or wiring connecting the ECU
- signal is not received by one or more sensors due to a faulty, broken or flat battery
- fault in the TPMS ECU.

Simultaneously, the specific warning light on the instrument panel (see page 151) starts flashing, and continues to flash for 90 seconds. The warning light then remains on in fixed mode until the situation is corrected.

The TYRES screen page cannot be called up by the driver.

System temporarily not active

The screen page shown in example 17 is displayed in the following circumstances:

- overheating of sensors
- during calibration (the TPMS ECU does not recognise the sensors)
- radio frequency that interferes with the wheel sensor signal.

Simultaneously, the specific warning light on the instrument panel (see page 151) starts flashing, and continues to flash for 90 seconds. The warning light then remains on in fixed mode until the situation is corrected.

The TYRES screen page cannot be called up by the driver.

System not active

For a few seconds at key-on, if the TPMS has been deactivated by a diagnostic tool, the screen page in example 18 is displayed.

Simultaneously, the specific warning light on the instrument panel (see page 151) starts flashing, and continues to flash for 90 seconds. The warning light then remains on in fixed mode until the situation is corrected.

The TYRES screen page cannot be called up by the driver.

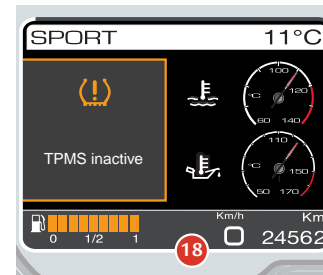
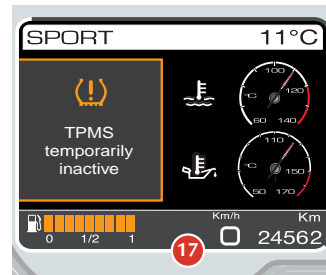
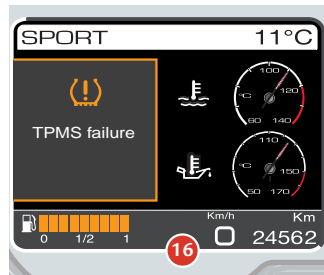



TAB 1. Child restraint systems that can be installed on the front passenger seat with 3-point seat belts

GROUP	WEIGHT RANGE	SEAT
		Front passenger
0	0 - 10 kg	X
1	9 - 18 kg	UF - L
2	15 - 25 kg	UF - L
3	22 - 36 kg	UF - L

2

TAB 2. Child restraint systems that can be installed on the rear seats with 3-point seat belts

GROUP	WEIGHT RANGE	SEAT	
		Driver-side, lateral rear	Opposite driver-side, lateral rear
0	0 - 10 kg	X	U - L
1	9 - 18 kg	U - L	U - L
2	15 - 25 kg	U - L	U - L
3	22 - 36 kg	U - L	U - L

**TAB 3.** Child restraint systems that can be installed on the rear seats with ISOFIX

GROUP	WEIGHT RANGE	SEAT	
		Driver-side, lateral rear	Opposite driver-side, lateral rear
0	0 - 10 kg	X	L
1	9 - 18 kg	L	L
2	15 - 25 kg	X	X
3	22 - 36 kg	X	X

TAB 4. Special FERRARI Baby Smart™ child restraint systems (produced by Britax-Römer)

GROUP	WEIGHT RANGE	Name
0	0 - 10 kg	BABYSAFE Plus
1	9 - 18 kg	DUO Plus
2	15 - 25 kg	KID Plus
3	22 - 36 kg	KID Plus



Warning



Before installing the KID Plus car seat on the rear seats, the cushion supplied with the car seat must be placed on the seat cushion as shown in **Figure 1**. This cushion must be used to ensure that the KID Plus car seat is correctly installed.

If you already have a KID Plus car seat but no cushion for rear seat installation, contact the FERRARI SERVICE NETWORK.

Warning



Only use the cushion with the KID Plus car seat. Remove the cushion if the seat is occupied by an adult.

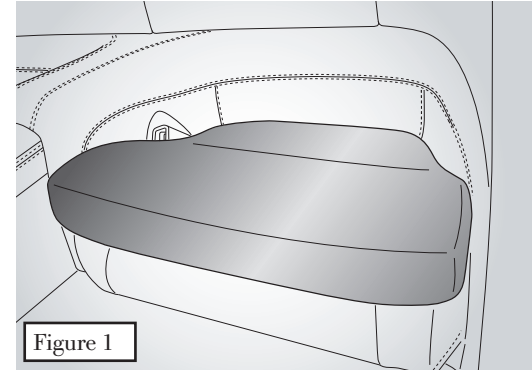

2

Key

U = suitable for “Universal” category restraint systems homologated for use in this weight group.

UF= suitable for forward-facing “Universal” category restraint systems homologated for use in this weight group.

L = suitable for the special restraint systems listed in TAB 4. These restraint systems can be “vehicle specific”, “limited” or “semi-universal”.

X = seat not suitable for children in this weight group.



1. General

2. Safety

3. About your Vehicle

4. Advice for Emergency Situations

5. Care of the vehicle

6. Glossary

7. Table of Contents







Controls overview



Ref.	Control	Page
1	Adjustable air vents	202
2	Glove compartment	202
3	Hazard warning lights control	128
4	Manometer display	156
5	Light switch	125



Ref.	Control	Page
6	“ENGINE START” button	159
7	“Manettino” control	159/177
8	Rev counter and gearbox display	153
9	TFT display	130
10	Speedometer	95/153
11	Turn indicators	127
12	Suspension damping delink button	181
13	High beam and flashing lever	125
14	Windscreen wiper stalk	161



Ref.	Control	Page
15	Cup holder	
16	Power window controls	92
17	“R” reverse control	169
18	“AUTO” control	172
19	“LAUNCH” control	180
20	Air conditioning controls	199
21	Retractable hard top opening/closing button	118
22	Emergency light button	128

Important note



The position of the “R”, “LAUNCH” and “AUTO” buttons on the centre console may vary according to the market. The button functions are the same.





Ignition switch

The ignition key can be turned to 2 positions:

Position 0 - Stop

Engine off, key removable.

The hazard warning lights and the parking lights can be activated.

Position II - Ignition

Turning the key to this position, the TFT display will check the signals coming from the vehicle systems.

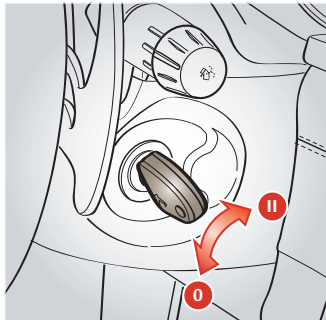

Warning



Always remove the key from the ignition when you get out of the vehicle!

Never leave children unattended in the vehicle.

Key lock

If more than 20 seconds elapse after turning the key to position 0, the key lock device must be released to remove the key.

Press button **K** in the slot under the steering wheel and remove the key at the same time.

3

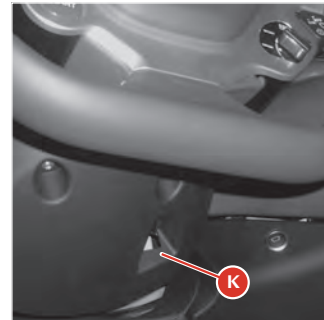



Doors

When a door is opened or closed, the window automatically moves down by approximately 2 centimetres (to its “target position”) to avoid colliding with the upper weather strip.

When the door is closed, the window automatically moves up until it reaches the “upper limit”.

Opening from the outside

Using the remote control, deactivate the alarm and the central door locking system, or turn the key in the lock to deactivate the central door locking system.

To open the door, pull handle **A**: the window will move down to its “target position”. When the door is closed, the window will move up until it meets the upper limit.



Locking and opening the doors from the inside

Warning



Always carefully check manually that the doors have been closed properly to prevent them from opening while driving.

Both doors can be locked by activating/deactivating the “LOCK/UNLOCK” **B** button on the roof panel. To lock the doors, press button **B**; when the door lock is activated, the light on button **B** comes on. To deactivate the door lock, press button **B** until the light goes out.

The rolling lock function, which automatically locks the doors when the vehicle speed reaches or exceeds 20 Km/h, may be activated from the “Car setup” menu accessible from the TFT display of the instrument panel (see page 132).





If you pull handle **C** to open the door, the window will move down to its target position. When the door is closed, it will move up until it meets its upper limit.

If handle **C** is lifted without opening the door, the window will move down to its target position and stop and if the door is not opened after 2 seconds, the window will move back up until it meets the upper limit. Therefore, to open the door, release handle **C** and pull it again.

When the opening handle is operated, both doors are unlocked.

3





Engine compartment lid

Opening

To unlock the engine compartment lid, pull the lever **D** underneath the steering column.

Stand in front of the vehicle, slightly lift the lid and pull the retaining lever **E** to the side of the lock and lift it.

The lid is held open by two gas struts **F**.

The engine compartment lid can also be opened with the ignition key at off.

Closing

Lower the lid until it is closed and press down near the lock until you hear it click in place.

Warning



Always check manually that the engine compartment lid has been closed properly to prevent it from opening while driving.





Luggage compartment lid

Opening

The luggage compartment lid can also be opened with the ignition key at off.

To open the luggage compartment lid, press button **H** on the driver side door or button **L** on the remote control and hold it for more than 2 seconds. You can also use the special knob to the right of the number plate lights or the button between the number plate lights.

The luggage compartment is illuminated by an internal light that comes on automatically when the luggage compartment lid is opened.

Warning



To avoid damage, check there is enough room to open the luggage compartment lid.



Important note



After removing the battery from the vehicle or disconnecting it from the electrical system, a door lock/unlock cycle must be performed using the buttons on the key when reconnecting so that the release button **H** resumes normal operation (electronic system self-acquisition procedure).

Closing

Using the grip on the inside, lower the luggage compartment lid until it touches the bodywork.

The lock will pull the lid down until it clicks in place.

Warning



Since the lock closes automatically, always keep your hands away from the area between the luggage compartment lid and the bumper.

3



Fuel filler cap and flap

Warning



Always turn off the engine during refuelling.

Do not smoke or use open flames when refuelling.

The following can be harmful for your health:

- fuel coming into contact with your skin;
- inhaling fuel vapours.

Opening

To open the fuel filler flap, press button **M** on the driver side door.

Closing

To close the fuel filler flap, push it until it clicks in place.



Capless filler neck

This vehicle has a capless filler neck for fuelling. This system allows you to refuel by opening the fuel filler flap and simply placing the nozzle in the filler neck without having to unscrew a cap and screw it up again.

Two flaps placed in series, both with airtight seals, act as a cap. The external flap is locked by a series of “teeth” and the only way to open the external flap correctly is by inserting a petrol pump nozzle.

Warning



Place the nozzle in the filler neck carefully to avoid damaging the device seal. Do not try to open the external flap of the filler neck by pushing it with your fingers or lever it open using unsuitable tools (e.g. screwdrivers). This may damage the external flap mechanism, compromising the seal integrity and safety of the system.





Warning



Do not overfill the fuel tank: this may cause the fuel to leak out.
After fuelling, wait for about 5 seconds before slowly removing the nozzle from the filler neck: in this way, the last drops of fuel will flow into the tank and will not drip onto the vehicle.

Warning



Do not place funnels or portable container nozzles in the filler neck.
If you need to refuel from a portable fuel container, use only the funnel supplied in the tool bag (see page 212) that releases the automatic closing device.

Emergency Opening

In the event of a failure of the fuel filler flap button, the flap can be opened manually.

Open the luggage compartment lid, turn the lock **E** and open the flap **F**.

Pull the emergency string **G**.

3

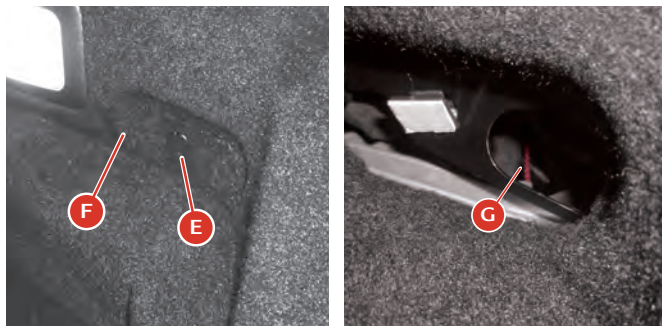



Power windows

The power windows can only be used with the ignition key in position II.

Driver-side power window

Press button **A** to move the window up or down. This button allows manual operation (partial opening/closing) or automatic operation (complete opening/closing). Press button **A** briefly to activate manual operation; if the button is pressed at length (over 0.3 seconds) the automatic window operation is activated. The window will only stop when it reaches the end of its travel or by pressing the button again.

Passenger-side power window

Press button **B** to move the window up or down.

Only manual operation is possible (partial opening) to raise the window: when button **B** is released, the window stops at the position reached.

To lower the window, automatic operation is also possible (full opening): if the button is pressed at length (over 0.3 seconds) automatic window operation is activated. The window will only stop when it reaches the end of its travel or by pressing the button again.

When the door is open, the window can only rise to the “*target position*”, to prevent the window from hitting the upper weather strip when it is closed.

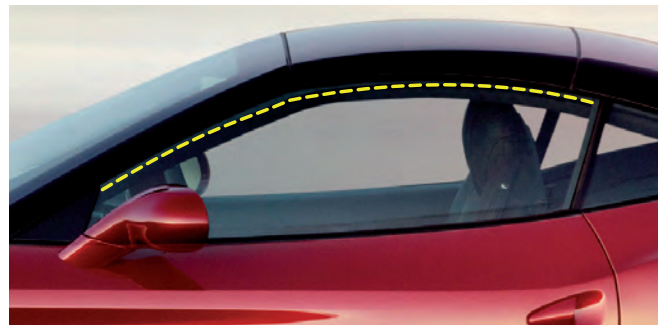
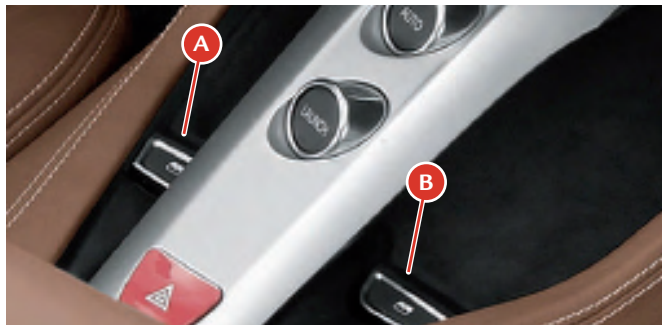



“Global Open” function

Quickly press the “Retractable hard top” button twice to open all four windows at the same time.

“Global Closed” function

Quickly press the “Retractable hard top” button and then hold it down to close all four windows at the same time.

Rear power windows

With the driver side front window lowered, press button **A** again to lower the driver side rear window.

With the passenger side front window lowered, press button **B** again to lower the passenger side rear window.

To raise the rear windows, simply lift button **A** for the left window and **B** for the right window.

Warning



Improper use of the power windows can be dangerous. Before use, always check that people and objects are at a safe distance.

Pay particular attention during the automatic operation of the driver-side power window.

To protect the passengers remaining in the car against accidental activation of the power windows, always remove the key from the ignition.



- 1 TFT Display
- 2 Electronic speedometer
- 3 Rev Counter
- 4 Gear display
- 5 Warning lights on the panel
- 6 Manettino status
- 7 Fuel level

Electronic speedometer

The speedometer indicates the actual speed of the vehicle.

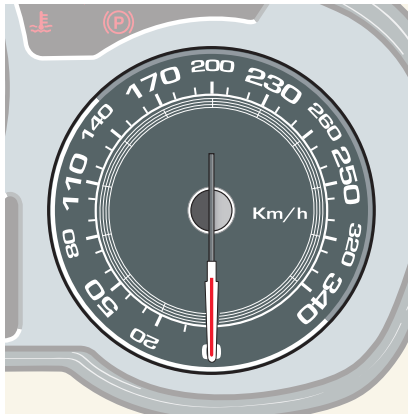

Rev Counter

The rev counter indicates the engine RPM.

The numbers on the dial multiplied by 1000 correspond to the engine RPM in one minute.

There is a space to the bottom right of the rev counter for the display which gives information on dual clutch transmission (DCT).

3

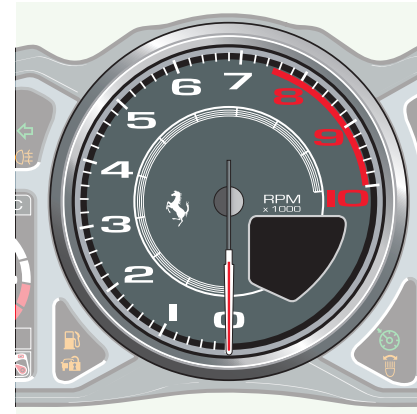



Infotainment system





Controls

- 1 RADIO mode
- 2 MEDIA mode
- 3 NAVI mode
- 4 PHONE mode
- 5 Volume control- ON/OFF
- 6 Call up main screen
- 7 PUSH TO TALK mode
- 8 Call up Options menu
- 9 Go to previous screen
- 10 Scroll control - Selection

3



Introduction

Characteristics

The vehicle infotainment system has the following functions:

- 6.5" touchscreen display
- FM/MW/DAB radio
- CD player (optional)
- USB/iPod®/iPhone® connector
- Satellite navigator
- Bluetooth connection

Recommendations

This manual contains indications (recommendations and information) intended to avoid actions that may cause accident or injury. Please observe all recommendations.

Safety information

Read this manual carefully before using the navigation system for the first time. Observe the safety information described in the manual. Contact the vehicle manufacturer if in any doubt.

Intended use

The navigation system complies with the standards used in navigation technology.

Always be aware of the regulations and guidelines in force in the country where the vehicle will be used.

Software update

The navigation data software can be updated. For the most recent software, contact the FERRARI SERVICE NETWORK.

Using the infotainment system safely

First of all, read the instructions in the manual carefully in order to use the system correctly. The infotainment system is not a toy and we do not recommend allowing children to use it without adult supervision.

Playing music at a very high volume can cause permanent damage to hearing and can be distracting for the driver, especially when driving at high speeds. Therefore, carefully adjust the volume.

Driving requires your full attention and care. If you are driving, we do not recommend using the infotainment system.

Important note



Several system functions depend on vehicle speed. For safety reasons, the touchscreen cannot be used to enter a name (the name of a street, for example) when the vehicle is moving.

Keep the system away from liquids and others sources of humidity. In addition to damaging the components, humidity can cause the electrical devices to shortcircuit.



Connections

Do not force the connectors into the car stereo system ports. Before connecting them, make sure that the connectors are the correct shape and size.

The connected cables must not exert any pressure on the connection.

Touchscreen

Do not touch the display with hard or sharp objects because they may damage the surface of the touchscreen (pens, USB sticks, jewellery, etc.).

Do not spray liquid or caustic chemicals directly onto the screen. Use a clean, dry microfibre lens cleaning cloth to clean the touchscreen.

If necessary, use a lint-free cloth dampened with a cleaning solution, such as isopropyl alcohol or an iso-propyl alcohol and water solution ratio of 50:50. Make sure you follow the solvent manufacturer's precautions and instructions.

CD player (optional)

Do not insert damaged, warped, scratched or dirty CDs into the CD player.

Discs that have been modified with an adhesive label should not be inserted in the CD player.

Do not insert more than 1 (one) CD at a time into the drive slot.

Insert supported CD formats only. See the "Disc Mode" section on page 106 for information on supported CD formats.

GPS navigation antenna

The antenna for the GPS navigation system is mounted in the dashboard.

Other electronic devices

Other electronic devices (PDA, iPod, computer laptop, etc.), may be used in the vehicle, some of which may cause electromagnetic interference with the GPS antenna. If you notice a reduction in GPS performance, switch off all appliances and move them as far away as possible from the GPS antenna.

Warning



As indicated in the general remarks referred to here, the driver can be distracted by a number of factors including the navigation/infotainment systems. The infotainment system should be used by the passenger where possible and, if used by the driver, should only be used when the vehicle is stationary.



User interface

The infotainment system information is displayed on the 6.5" display in the centre of the dashboard. Users can interact with the system by pressing the screen which uses touchscreen technology and using the controls located on both sides of the display and behind the steering wheel.

Warning



Do not touch the display with hard or sharp objects because they may damage the touchscreen surface.

Controls on dashboard

1) RADIO

Press button 1 to go to Radio mode.

2) MEDIA

Press button 2 to go to Media mode.

3) NAVI

Press button 3 to go to Navi mode.

4) PHONE

Press button 4 to go to Phone mode and/or connect a phone.

5) VOLUME CONTROL- ON/OFF

Hold down button 5 to switch the infotainment system on/off and turn the button to adjust the volume. Quickly press to put the system into MUTE mode.

6) MAIN

Press button 6 to go to the main infotainment system screen.

7) PTT

Press button 7 to activate the voice commands.

8) OPTION

Press button 8 to access the options menu for the screen that is displayed.

9) BACK

Press button 9 to go back to the previous screen.

10) SCROLL CONTROL

Rotate button 10 to go from one screen to another and press the button to select the desired option. The button has dual functions in Radio and Media modes which can be configured from the settings menus.





Controls on the steering wheel

As well as using the commands on both sides of the touchscreen display, the infotainment system can be controlled using buttons located on the back of the steering wheel as indicated by the arrows in the figure.

Buttons **A** and **B** for volume control and button **PTT C** are on the left-hand steering wheel spoke: press button **A** to increase the volume and press button **B** to decrease it. Hold down button **B** to mute the volume (MUTE function). To deactivate volume muting, press button **A**.

Button **C** is used to activate the voice commands; if the voice recognition function is already activated, it can be deactivated by quickly pressing button **C**. If there is an incoming call, quickly press button **C** to accept it or hold it down to refuse it.

The **SCAN + D** and **SCAN - E** buttons are on the right-hand steering wheel spoke. They are used to scan the radio stations (if RADIO mode is activated) or go to the next or previous track (if MEDIA mode is activated). The **SOURCE F** button is used to select the available sources (FM, MW, DAB, USB).

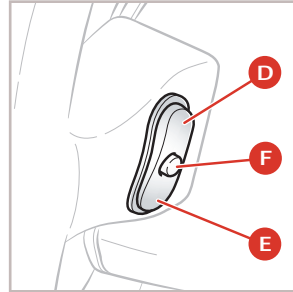
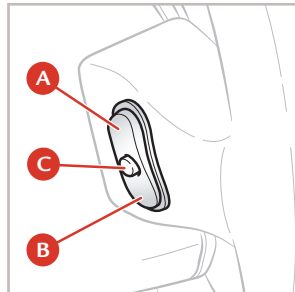

Repetition on display of infotainment system information

You can select whether to also display infotainment system information on the TFT display in the instrument panel via the MENU function on the TFT display.

If repetition is activated, the MEDIA information is displayed in minimised form on the left of the TFT display whereas information on the phone and navigation functions are displayed on the right.

To activate/deactivate repetition of infotainment system information, call up the MENU screen page using the controls on the dashboard to the left of the steering wheel, select “Display setup” and then select either ON or OFF for repetition of audio information.

3

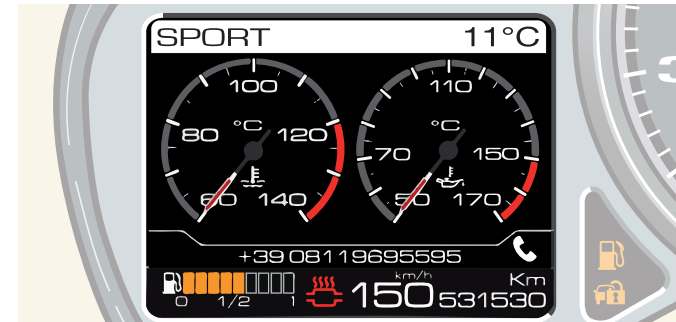



System settings

To access the system settings from the main screen, press the OPTION button on the right of the display or the SETTINGS soft key.

Audio control

Once you are in the SETTINGS menu, press the “Audio” soft key to access the audio control menu. You can adjust the balance/fading and equalisation of the stereo system, activate/deactivate “Quantum Logic” (if present) and adjust the volume according to the speed on this page.

To adjust the balance and fading, press the arrow soft keys.

The equalizer settings can be used to adjust the bass (BASS), mid (MID) and treble (TREB) levels.

Press the “Quantum Logic” soft key to activate/deactivate the option.

The volume can be adjusted to the speed on 3 levels or deactivated.



Adjusting display brightness

From the main screen, press the OPTION button on the right of the display or the SETTINGS soft key and select “Display”. For set the display brightness, select “Display Brightness” and set the day and night brightness levels. In both cases, the brightness can be adjusted by using the soft keys on the display.

In the Display settings menu, if “Auto Colour Mode” is selected, the display automatically adopts daytime or nighttime mode depending on the ambient light or how the vehicle light switch is set.



Pair a Bluetooth Phone/Audio device

From the main screen of the navigator, press the OPTION button on the right of the display or the SETUP soft key and select “Bluetooth Phone/Audio”. Press the “+ Add Device” soft key to pair a new Bluetooth device (telephone, tablet, laptop, etc.).

The icons on the right showing a phone and music indicate to the user the type of device connection and whether it is music only, phone only or both.

After pairing and selecting a peripheral, press the “OPTION” button on the right of the screen to access the Bluetooth device settings. Here you can tell the system to give priority to the peripheral selected using the “Setting Priority” option.

3

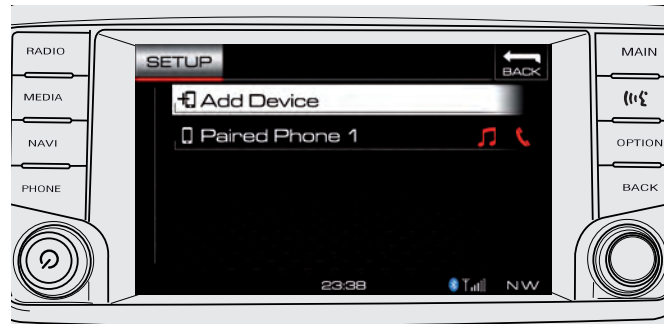



RADIO function

Press the RADIO button to the left of the display once to access the correct mode. To switch between the FM, MW and DAB sections, press the soft keys or press the RADIO button several times.

Selecting a radio station

Once you have selected the desired band, you can begin automatic scanning of the radio stations by turning the right button or manually enter the desired frequency by using the numeric keypad which can be accessed from the Radio options menu (see page 105). You can also select the desired radio station from a list by pressing the “List” soft key. The list has two display options - the first shows the radio stations stored as “Favourites” whereas the second shows the radio stations with the strongest signal in the area. To change display mode, press the “Go to favourites/Go to strongest stations” soft key at the top of the list or use the Smart Icon  on the right of the screen.



Storing favourite radio stations

You can store your favourite radio stations for each frequency band. To set a favourite radio station, find the station with the right button or numeric keypad and press the Smart Icon showing a star  on the right of the screen.

Scanning favourite radio stations

To scan just your favourite radio stations, press the Smart Icon . With this function activated, turn the Scroll Control to scan the stations previously saved as favourites.

To display the list of stored stations, press the “List” soft key in the bottom part of the display and select the “Go to favourites” display mode.





DAB radio

Digital radio has some additional options: artists/musical genres can be indicated as favourites.

Radio settings

When you are in one of the three bands FM, MW or DAB, press the OPTION button to the right of the display to access the settings menu.

3





MEDIA function

Press the MEDIA button to the left of the display once to access the correct mode. To switch between the DISC (if present), BLUETOOTH and USB sections, press the soft keys or press the MEDIA button several times.

Disc mode (DISC)

If the system has a CD player (optional), it is installed in the glove compartment on the passenger side:

Important note



When placing a disc in the player slot, make sure the label is facing upwards.

Insert the disc in the slot: the system pulls it into the player. Once it has recognised the disc, the system selects the appropriate mode and starts to play the first track.

Warning



The player only accepts 12 cm (4 ¾ inch) discs. Using discs of any other format may damage the player mechanism.

The system can play compact discs (CD), recordable compact discs (CD-R) and rewritable compact discs (CD-RW).

The system plays these formats: MP3, WMA, CD Audio.

Insert supported CD formats only.





Playing a disc

After inserting a disc in the player, the system selects the appropriate mode once it has recognised the disc and starts to play the first track.

To go on to the next or previous track, you can use the right button or buttons **D** and **E** behind the right-hand spoke of the steering wheel.

To display and scroll through the list of multimedia content on the CD, press the “List” soft key in the bottom of the display.

To fast forward or rewind a track, go to the desired mode by pressing the “Smart Icon”  on the right of the display and turn the right button and re-press the “Smart Icon”  so that the right button goes back to the previous function (go to beginning/end). To activate the “Shuffle” play mode, press the relative “Smart Icon” .



Disc mode settings

While you are in disc mode with a disc inserted, press the OPTION button to the right of the display to access the options menu. Here you can activate/deactivate the “Shuffle” mode, activate/deactivate the “Repeat” mode, select the right button operating mode (FF/FRW or go to beginning/go to end) and access the “Audio Settings”.

3





Bluetooth mode

In Bluetooth mode, you can play audio files stored on external devices. These can be connected to the system via the Bluetooth connection once the device has been paired (see page 103).

Important note



The “List” function cannot be used in Bluetooth mode.

Bluetooth mode settings

While you are in Bluetooth mode with a paired peripheral, press the OPTION button to the right of the display to access the options menu. Here you can activate/deactivate the “Shuffle” mode, activate the “Repeat” mode, access the Bluetooth device settings and access the “Audio Settings”.



USB mode

The USB mode provides access to the files in the USB peripheral connected to the system via connector **A** in the pocket change compartment on the centre console.

USB connection

Using the USB connector, you can also play audio files from iPod® and iPhone® devices, using the USB cable supplied with the device.

Warning



Do not force connectors into the infotainment system ports. Before connecting, make sure that the connectors are the same shape and size as the port.

Playing multimedia content is the same as the disc mode. See page 106.

USB mode settings

While you are in USB mode with a USB peripheral connected to the system, press the OPTION button to the right of the display to access the options menu. Here you can activate/deactivate the “Shuffle” mode, activate/deactivate the “Repeat” mode, select the right button operating mode (FF/FRW or go to previous track/next track) and access the “Audio Settings”.



Navigation function (NAV)

Warning



Drive carefully, keep your eyes on the road and comply with road regulations.

Press the NAVI button to the left of the display to go to Navigation mode.

Press the NAVI button again to switch from the main “Navi” screen to the Map and vice versa.

When the main “Navi” screen is displayed on the right of the display, “Smart Icons” appear which can be used to rapidly access several navigation options:

- STOP

This stops navigation.

- Detour

This is used to select a detour/alternative route.

- Repeat

This repeats the last voice command.

3





Main Navi menu

The main NAVI menu has the following menu items:

- Show Map

Press the “Show Map” soft key to display a map of the current position. See the “Show Map” section for details.

- Destination Entry

Press the “Destination Entry” soft key to plan your destination.

- Go Home

Press the “Go Home” soft key to follow the route to the preset “Home” position.

- Favourites

Press the “Favourites” soft key to enter a point of interest from a list of preselected favourite places, also available when the vehicle is moving.

- Recent Destinations

Press the “Recent Destinations” soft key to call up a recent destination.

- POI (Point of Interest)

Press the “Point of Interest” soft key to select a destination from the list of positions, public places or points of interest. Search by name, telephone number, category or type of place.

- Emergency

Press the “Emergency Info” soft key to follow the route to an emergency service near the current position of the vehicle. This includes the fire brigade, police, hospitals.

- Trips

Press the “My Trips” soft key to enter a point of interest from a previously saved list of itineraries.

- Where Am I Now

Press the “Where Am I Now” soft key to find your current position.

Destination entry using an address

Press the “Destination Entry” soft key on the display to display the available options.

To enter the destination by manually entering the address, press the “Address” soft key. You can also head for a “City Centre”, “Intersections” or choose a city from the list of “Closest Cities”.





Alternatively, you can enter the destination by selecting a point on the map or entering the coordinates or phone number.

Once you have pressed the “Address” key, you are asked to enter the Country, City, Post Code and Address.

Important note



For safety reasons, you cannot use the keyboard to enter a name when the vehicle is in motion.

As you type in the name, the number of possible roads decreases. Once you have selected the road, enter the number.

If you press “Skip” the number is not entered and the navigator takes you to the part of the street nearest to the current position.

The planned route can be interrupted at any time by pressing the “STOP” Smart Icon in the main NAVI menu.

Navigation options

To access the Navigator options, go to the main NAVI screen, press the button on the right of the “OPTION” display and select “NAVI Options” from the display menu.

3

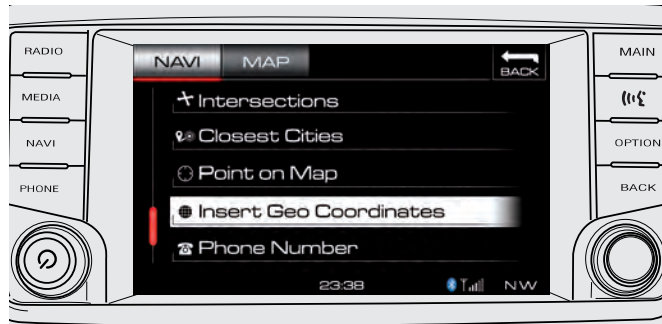



The navigation options can be used to access the following sections:

- Map Configuration.
- Speed Limit.
- Guidance (driving options while navigating).
- GPS.
- TMC Station List (traffic information).
- Preset Route.
- Cancel all Destinations.
- Cancel Home Address.



MAP settings

Once the planned route has started, from the MAP section you can change some of the navigation settings by pressing the “OPTION” soft key on the right of the display.

- Map: 3D/2D

This is used to select the map display mode.

- Rotate for Zoom

This is used to select whether to assign the zoom function to the SCROLL CONTROL during map display.

- Stop Navigation

This stops navigation.

- Repeat Prompt

This gets the system to repeat the last navigation voice command.

- Divert

This plans a different route by taking a detour from the current route: the navigator displays a list of the possible detours to choose from.

- Complete Route

This displays the complete route on the map.

- Hide POI

- Turns

- Where Am I Now

- NAVI Options (see page 111).

- Traffic Events

This displays a list of traffic events for the set route.



To go back to the main Navi screen, press the soft key  displayed in the bottom left of the display or press the NAVI button on the left of the display.

3





Telephone function

The telephone function is a hands-free in-vehicle communications system that allows you to dial a phone number with your mobile phone by using simple commands or the soft keyboard that appears on the display.

Your phone's audio is transmitted via the vehicle audio system; when the telephone function is used, the infotainment system automatically mutes the car radio.

To use the telephone function, you must first of all pair a Bluetooth-compatible mobile phone (see page 103).

Important note



2 phones can be connected to the system, one with the "Phone" function and one with the "Audio streaming" function (playing of music). A phone which has been assigned the "Audio streaming" function cannot be used for the "Phone" function and vice versa.



Important note



For an up-to-date list of compatible phones, contact the **FERRARI SERVICE NETWORK**.

Press the PHONE button to the left of the display to go to Navigation mode.

Three soft keys are displayed in the bottom of the display which can be used to access the functions: Contacts, Favourites and Recents.

Contacts

Press the "Contacts" soft key to access the paired phone's address book. A "Smart Icon" appears on the right that can be used to sort and/or display the list by name or surname. A contact can be assigned as a favourite by pressing the Smart Icon

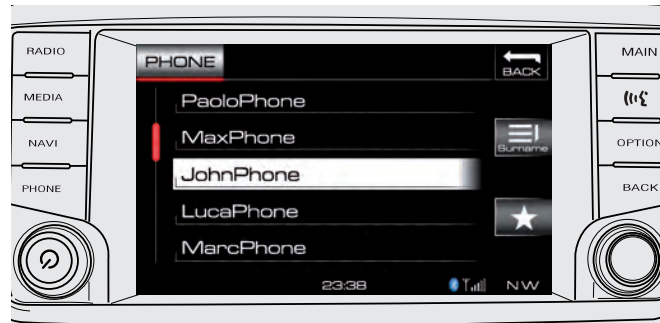



Search



You can search for a contact by entering his or her name in the “Search” field above the contact list.

Favourites

From the main “Phone” screen press the “Favourites” soft key to access the list of favourite numbers which have been previously saved from the “Contacts” list.

Recents

Press the “Recents” soft key to access the list of numbers used recently.

Three “Smart Icons” appear on the right which can be used to filter the “Incoming Calls” , “Outgoing Calls”  and “Missed Calls” .



Making a call

To make a call, you can select a contact from the “Contacts”, “Favourites” or “Recents” lists or manually enter the phone number using the soft keyboard that appears on the display; to redial, use the “Smart Icon”  displayed on the main “Phone” screen.

PTT function

The Push To Talk function is a hands-free in-vehicle communications system that allows you to navigate the system by using simple voice commands.

To call up this function, press button  to the right of the screen.

If you give the voice command “Guidance”, the system reads out a list of voice commands for the displayed screen.

3





Parking Camera function (optional)

“Rear Parking Camera” screen (optional)

If the vehicle has a rear parking camera (optional), the “Rear Parking Camera” screen is automatically displayed on the infotainment system display when rear gear is engaged. This screen, which is displayed as long as the vehicle is in reverse gear, shows the view range of the camera mounted on the rear bumper and helps the driver when parking.

With reverse gear engaged, press button **C** on the dashboard to switch between:

- rear view with grids;
- rear view with wide angle lens.

The image is integrated with dynamic parking grids in green, yellow and red which, based on the steering angle, estimate and indicate the vehicle's path to the driver during the manoeuvre.

The dynamic parking grids also indicate the distance from any obstacles in the camera's view range: the area within the red grid represents an area that ranges from 0 to 60 cm, the yellow one from 60 to 120 cm and the green one from 120 to 240 cm.

To exit the “Rear Parking Camera” mode and go back to the infotainment system screen, hold down button **C** for a few seconds or disengage reverse gear if it is engaged.

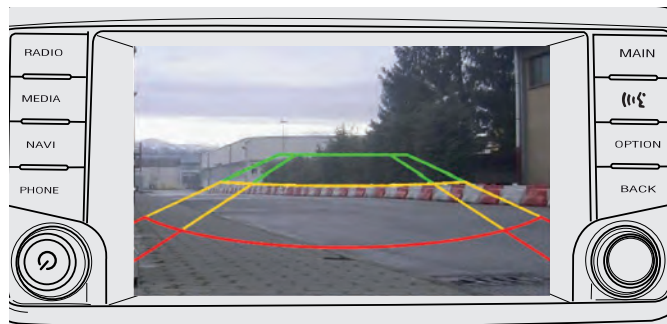



“Dual View Camera” screen (optional)

If the vehicle has a “Dual View Camera” system consisting of another camera mounted in the front bumper as well as a rear parking camera, the following views appear on the display:

- front lateral “Corner View”;
- central front “Top View”;
- rear view with grids (with Rear Parking Camera);
- rear view with wide angle lens (with Rear Parking Camera).

When reverse gear is engaged, the “Rear Parking Camera” screen is automatically displayed on the infotainment system display.

Without engaging reverse gear, you can switch to the “Corner View” mode (front camera) by pressing and quickly releasing button **C** on the dashboard to the right of the steering wheel.

The view can be selected by pressing button **C**: press and quickly release button **C** to call up the “Corner View”. Press the button again to switch from one view to another.

The front camera image display is disabled if the vehicle exceeds a speed of 12 km/h.

To exit the “Dual View Camera” mode and go back to the infotainment system screen, hold down button **C** for a few seconds.

If one of the two rear views is displayed when reverse gear is engaged, the system switches to displaying the “Corner View” screen as soon as reverse gear is disengaged.

3

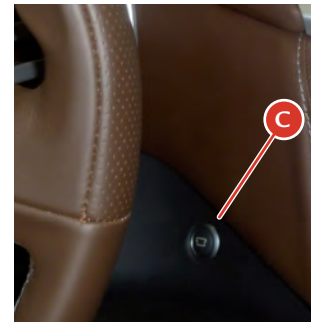



Retractable hard top

The hard top system is composed of three main moving parts:

- top section;
- rear section with rear window;
- luggage compartment lid.

Opening and closing is actuated by a hydraulic system, driven by a pump and controlled by a number of sensors that check every opening and closing phase.

Warning



For safety reasons, the retractable hard top can only be opened and closed when the vehicle is stationary.

Warning



The roof must be opened or closed while remaining correctly seated in the driver's seat.

Warning



Before activating the roof and while it is in motion, always check that people and objects are at a safe distance from the moving parts of the roof. In the event of danger, release the roof switch; all movement will stop immediately.

Important note



Before opening or closing the hard top, refer to the "Placing suitcases in the luggage compartment" section on page 205.

Warning



Before operating the retractable hard top, make sure that the backrest of the child restraint system is set to its minimum height.

The conditions required for opening and closing the retractable hard top are the following:

- the vehicle must be stationary;
- the luggage compartment must be closed;
- the battery voltage must not be below 11 volts;
- the partition between the luggage compartment and the folded roof compartment must be in the correct position, fully pushed back and fastened;

Warning



Do not place items above the partition! Risk of serious damage to opening and closing mechanisms.





- check there is adequate space heightwise and in the rear of the vehicle: the minimum available height **A** must be 1700 mm, the minimum distance **B** of an obstacle from the rear must be more than 400 mm;
- the ignition key must be in position II and the engine running;

Important note



We recommend operating the retractable hard top with the engine running.

Important note



If distance **B** is less than 400 mm, the parking sensors will not allow the roof to open or close.

The parking sensors are only activated when the key is in position II.

- the hydraulic system must not be overheated.

If one or more conditions are not met, the relevant message will appear on the TFT display.



Roof opening using the switch

Important note



Before opening the roof, ensure that the top of the roof and the rear window are dry to prevent water from entering the passenger compartment or luggage compartment.

Pull back switch **A** on the centre console and hold until the roof is completely open.

The operation in progress will be indicated by a warning on the TFT display.

When the button is pressed, a series of operations required to open or close the retractable hard top begins:

- the side windows are lowered completely;
- the rear window is raised;
- the luggage compartment lid rotates around a hinge fitted in its rear part;

3

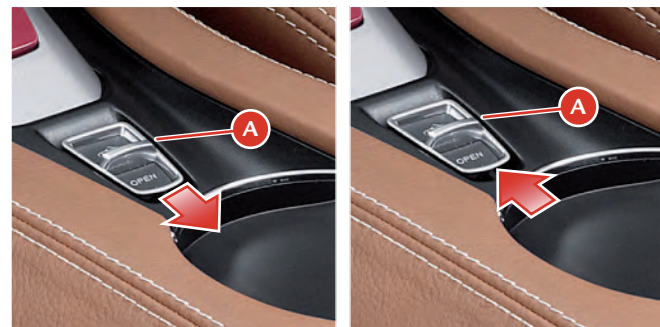



- the rear window and luggage compartment lid parts are positioned in the luggage compartment;
- the luggage compartment lid is closed.

Important note



Throughout all these phases, the side windows cannot be activated.

At the end of the opening cycle, an acoustic signal will indicate the end of the operations and the relative phase will be indicated with a message on the TFT display.

Warning



Do not reverse the opening or closing direction when opening or closing the roof.

Always complete the cycle until the acoustic signal is emitted.

Roof closing using the switch

Push switch **A** on the centre console forward and hold it until the roof is completely closed.

The operation in progress will be indicated by a warning on the TFT display.

When the button is pressed, a series of operations required to open or close the retractable hard top begins:

- the side windows are lowered completely;
- the luggage compartment lid lifts and rotates backwards;
- the top section of the roof comes out of the luggage compartment and rests on the edge of the windscreen bay;
- the luggage compartment lid completes the closing phase;
- the rear window starts moving back and goes into position.

Once the operation has been completed, an acoustic signal indicates that the switch can be released.

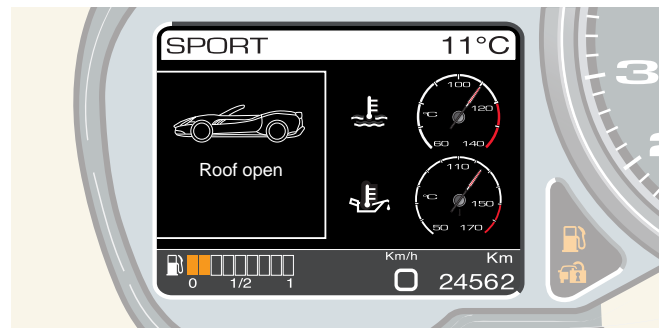
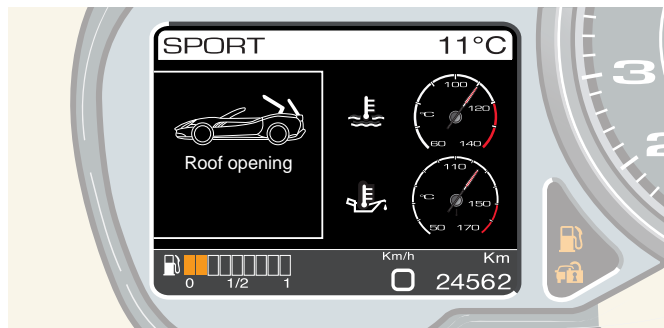

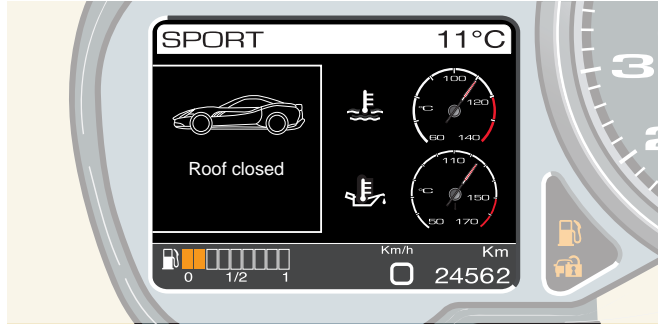

Operation on stand-by

If the button is released before the retractable hard top has been completely opened or closed, a message will appear on the TFT display and will remain displayed until the opening or closing cycle is reactivated.

Warning



Do not drive until opening or closing has been fully completed.

A few minutes after the roof is in stand-by position, an acoustic signal and message on the TFT display will prompt you to complete the operation.

Warning



Avoid interrupting opening and closing of the retractable hard top. If the procedure has to be interrupted, you must avoid leaving the hard top in a stand-by position for more than 4 minutes.

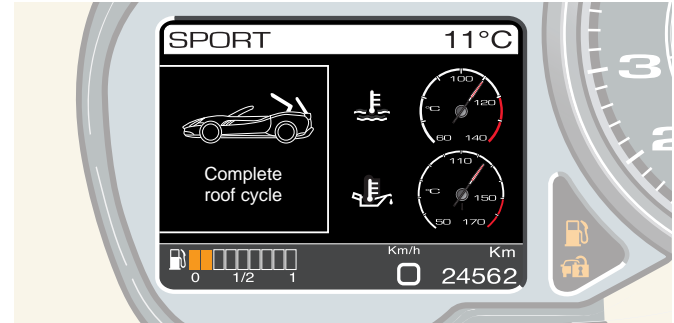

3

Operations not allowed

If the conditions for opening or closing the retractable hard top are not met, this will be indicated by an acoustic signal and a message on the TFT display:

- roof activation during vehicle motion;

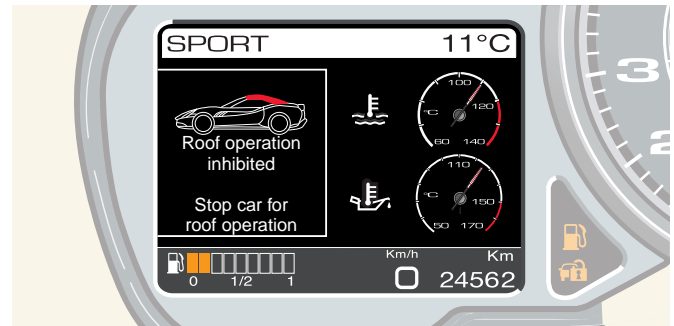



- the speed signal transmitted via the CAN network is not detected by the ECU;
- the luggage compartment has not been closed correctly;

- the battery voltage is below 11 volts;

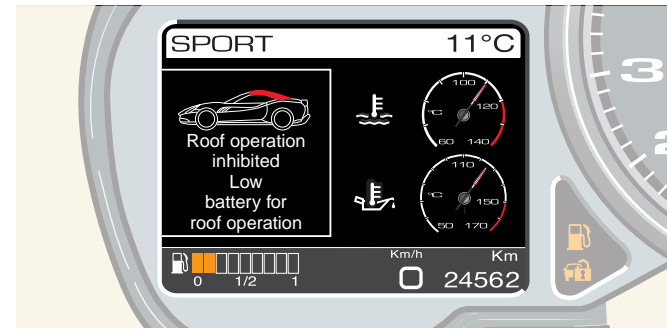

- the partition between the luggage compartment and the folded roof compartment must be in the correct position, fully pushed back and fastened;

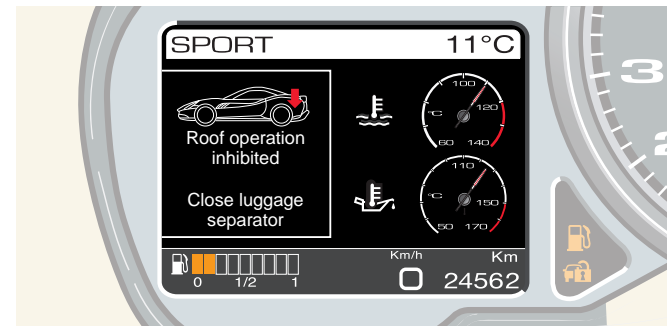
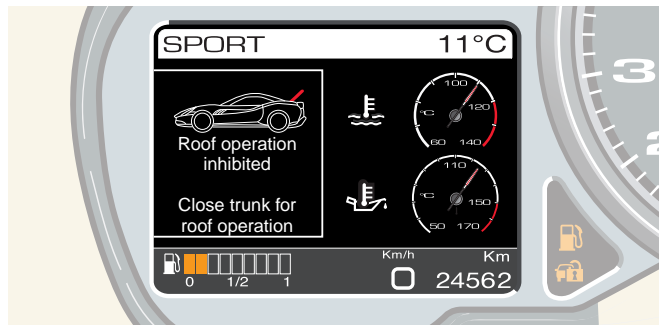



- the hydraulic system is overheated;
- the window position sensor detects that at least one of the windows is not in the correct position;

- the parking sensors have detected an object in the rear of the vehicle;

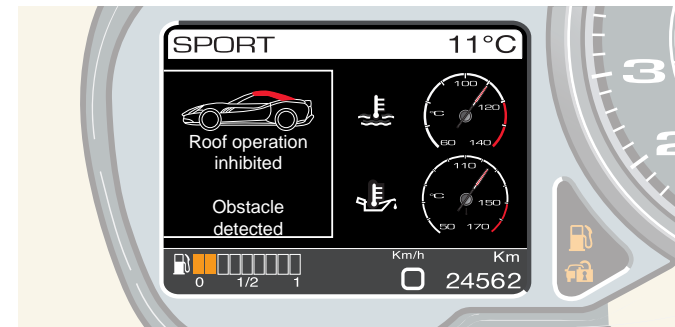
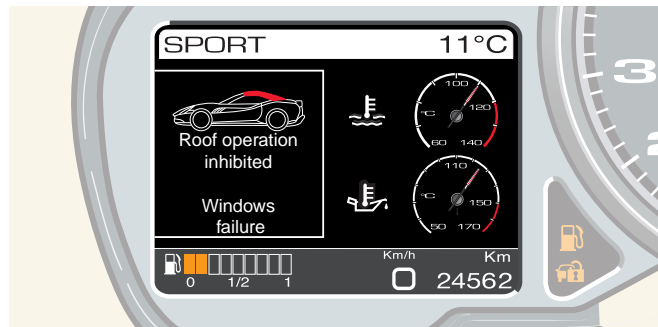
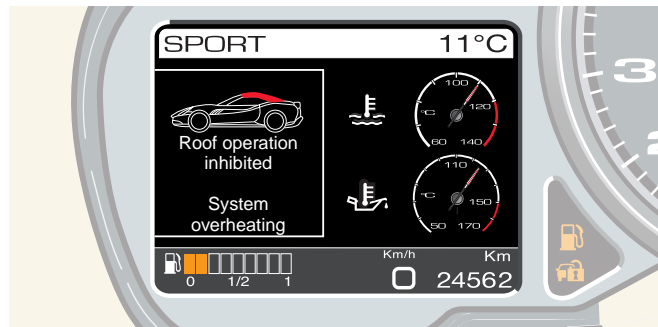

3



- the parking sensors are not communicating with the ECU.

Warning



DO NOT open the retractable hard top when the outside temperature is below -10°C (14°F).

Warning of faulty opening and closing

If there is a problem with opening and closing the roof, the fault will be indicated by an acoustic signal and a message on the TFT display.

After 20 seconds or after pressing the MENU button, the screen page is reduced to an icon and moves to the bottom of the TFT display.

Warning



If there is a fault in the retractable hard top system, contact the **FERRARI SERVICE NETWORK**.

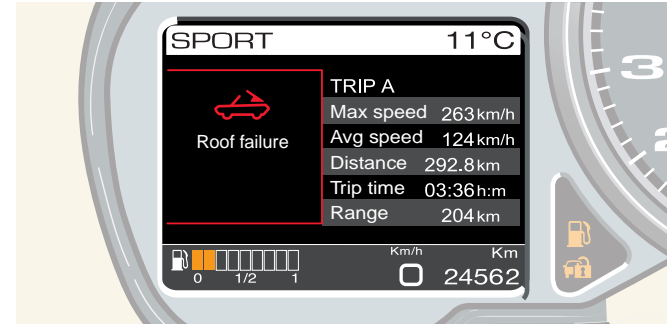
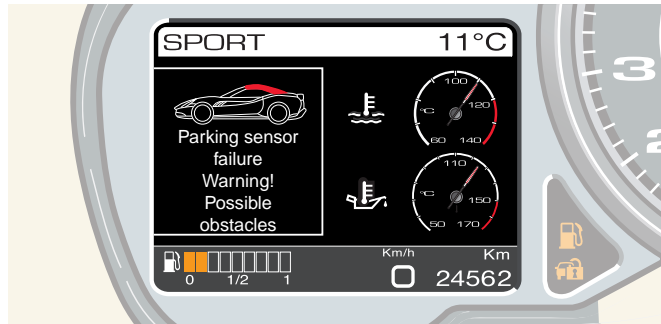





Lighting

The external lights and turn indicators only work when the ignition key is in position **II**.

The external lights can be switched on and off manually or automatically, depending on the ambient light.

Light switch



Switch **A**, on the dashboard to the left of the steering wheel, can be set to four different positions:

- 0** Lights off
-  Low beams on (*)
-  Parking lights
- AUT** Automatic operation of the external lights according to ambient light.

(*) The relative warning light on the instrument panel comes on.



High beams

To turn on the high beams when the light switch **A** is set to , push lever **B** on the steering wheel towards the dashboard. When the high beams are on, the relative warning light  on the instrument panel comes on.

Then push lever **B** towards the dashboard or pull it back to turn off the high beams and turn on the low beams.

Flashing the headlights

The headlights can be flashed by pulling back the left-hand lever **B**.

Flashing also occurs with lights off if the ignition key is set to **II**.

The high beams are used for flashing.

Important note 

Follow the Road Regulations of the country you are travelling in for using the high beams.

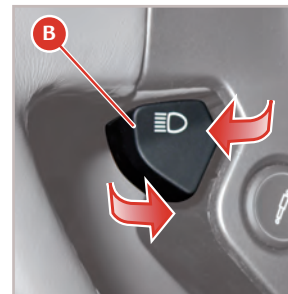

3



Parking lights

The parking lights work only with the ignition key in position **0** or with the key removed.

They are activated by turning the light switch **A** to position **P**.

When the parking lights are on, the warning light illuminates on the instrument panel .

When the parking lights are on, press and hold one of the two turn indicator buttons **C** on the steering wheel (see page 127) for more than 0.5 seconds to turn on the single-side parking lights on the corresponding side; press the same turn indicator again for more than 0.5 seconds to go back to full parking lights.

When the partial parking lights are on (on only one side of the vehicle), the running light warning light  turns off whereas the vehicle symbol indicating which parking light is on (left or right) is displayed on the left TFT display for 10 seconds.

When the light switch **A** is turned to **AUT** and the ignition key is in position **II**, the running lights, low beams and number plate lights turn on and off automatically according to the ambient light.

Important note

The high beams can only be activated manually by pushing the left-hand lever **B** towards the dashboard.

Important note

If the high beam control is activated, the high beams will turn on every time the lights are activated automatically. We recommend therefore that you turn them off every time the twilight sensor deactivates the external lights.

Warning

If there is fog during the day, the running lights and low beams will not be turned on automatically. The driver must always be ready to turn on the lights manually and also the rear fog lights, if necessary.

Important note

After automatic activation of the external lights, it will always be possible to turn on the rear fog lights manually. When the external lights are deactivated automatically, the rear fog lights are also turned off (if active) automatically. Therefore, if necessary, the driver will have to turn on the rear fog lights manually upon the next automatic activation.

Warning

The driver is always responsible for turning on the external lights, depending on the ambient light and in compliance with the regulations in force in the country of use. The automatic system for turning on and off the external lights must be considered an aid for the driver. If necessary, turn the lights on and off manually.



Twilight sensor

The twilight sensor is comprised of a global sensor which measures the ambient light upwards.

Sensor sensitivity can be set to three levels: call up the MENU screen page, select the items “Car setup” and “Light sensor” and use the **UP** and **DOWN** buttons to select the desired level.

In the event of sensor failure, the system switches on the low beams and running lights, regardless of the daylight conditions; a failure message will appear on the instrument panel display.

The failure indication will be displayed as long as the light switch is turned to **AUT**. If this occurs, we recommend that you deactivate the automatic system and turn on the external lights manually if necessary.

Important note





If this occurs, contact the **FERRARI SERVICE NETWORK**.

Day lights

The LEDs on the headlights serve as front turn indicators and day lights. To activate or deactivate the day running lights, call up the MENU screen page on the left TFT display, select the items “Car setup”, “Day lights” and select ON to activate the function and OFF to deactivate it.

Turn indicators

Quickly press the left indicator or right indicator button **C** on the steering wheel to switch on the relevant turn indicator.

The relative warning light  or  on the instrument panel comes on.

The turn indicator goes off when the steering wheel is realigned.

Holding down one of the two **C** buttons (for more than 0.3 seconds) temporarily switches on the relevant turn indicator: it is switched off after 3 flashes (“lane change” function).

3





Rear fog lights

The rear fog lights are turned on only if the high beams or low beams are on when button **D** is pressed; the relevant warning light **E** on the instrument panel comes on to indicate that they have been turned on.

Important note



Use the rear fog lights only in poor visibility conditions.

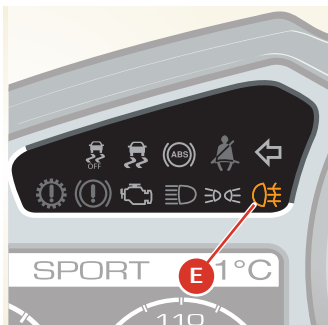

Hazard warning lights

Press button **A** to turn on the hazard warning lights. All the turn indicators will start blinking intermittently. These lights will operate with the ignition key in any position.

When the hazard warning lights are on, the relative warning lights on the instrument panel and the button flash.

To turn them off, press the button again.

“Auto Hazard” function

The “Auto Hazard” function automatically switches on the hazard warning lights in the event of sharp braking.

To activate or deactivate the function, call up the MENU screen page, select the items “Car setup”, “Auto Hazard” and select either “ON” or “OFF”.

“Follow me home” function

With the “Follow me home” function, the low beams stay lit for a preset period of time once the engine has been turned off and light up the area around the vehicle to help the driver and passengers see their way in the dark.





To activate this function manually, push the high beam/flash stalk **B** (see page 125) with the ignition key turned to **0** or removed, within 3 minutes of switching off the engine. This timer is reduced to 30 seconds if the driver side door is opened. Each time lever **B** is pressed, the period of time that the low beams remain on increases by 30 seconds up to a maximum of 210 seconds.

Each time lever **B** is pressed, the message “Follow me” appears on the left TFT display followed by the preset period of time that the low beams remain on.

AFS2 adaptive headlights (optional)

The AFS2 adaptive headlight system (available on request) enables synchronous movement of the left and right front beams (high and low) and has been designed to illuminate the road better and reduce areas of shadow in the vehicle's trajectory.

The headlights' swivel angle, which ranges from 8° inwards and 15° outwards, is defined by the steering angle.

The AFS2 system also uses a “Dynamic Levelling” device that directs the light beam vertically when accelerating and braking by moving the headlights up to 1.9° upwards when braking and up to 1° downwards when accelerating.

The adaptive headlight system deactivates its corrective action when driving round bends at low speed.

Dome light

When the doors are closed, the dome light **D** on the roof can be turned on or off using the switch **E**.

Switches **F** and **G** turn the driver-side and passenger-side spotlights on and off.

The dome light activates automatically in the following conditions:

- when a door is opened, for approx. 3 minutes;
- when all the doors are closed and the key is in position **0**, for approx. 10 seconds;
- when the key is removed, for approx. 10 seconds;
- when the doors are unlocked, for approx. 10 seconds;
- when the inertia switch is activated, for approx. 15 minutes.

The dome light deactivates automatically in the following conditions:

- after the preset activation time expires;
- when the doors are closed and the key is in position **II**;
- when the doors are locked;
- when the inertia switch is reactivated.



3



Left TFT display

Located on the instrument panel, it performs the following functions:

- displays the control parameters;
- displays general information while driving;
- displays fault warnings.

The driver can interact with the system by selecting the configuration and setting the parameters using the controls on the dashboard to the left of the steering wheel.

The display is activated and set by pressing the MAIN (A), VDA (B), OK (C) and UP, DOWN, LEFT, RIGHT (D) buttons.

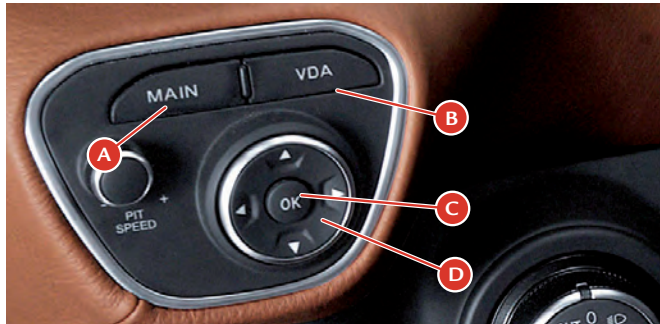

MAIN screen page

If you press the MAIN button, you activate the MAIN screen page which can be used to access the four screen page groups SETUP, VDA, TRIP and STATUS. These groups contain the following screen pages:

SETUP (pressing the UP button)

MENU screen page

STATUS (pressing the DOWN button)

SPORT screen page

SPORT 2 screen page

TYRES screen page (only if TPMS is present)

VDA (pressing the LEFT button)

Manettino status screen page

TRIP (pressing the RIGHT button)

TRIP A screen page

TRIP B screen page (only if previously enabled).





Press the **RIGHT** and **LEFT** buttons to sequentially switch between screen pages in a group. Press **RIGHT** to go to the next screen page (for example, in the **STATUS** group from **SPORT** to **SPORT 2**) and press **LEFT** to go to the previous screen page. Press the **RIGHT** button after the last screen page to go back to the first screen page and press the **LEFT** button after the first screen page to go back to the last screen page.

Six different screen areas are available, depending on the information type chosen:

- A** - selected driving mode (Manettino setting), outside temperature and “Warning: danger of ice” icon;
- B** - display of control gauges, parking sensor screen, display of abnormal events/warnings (message text and special symbol, when available), display of brightness adjustment function;
- C** - multimedia info;
- D** - call inform/address book;
- E** - fuel level gauge, fault icon and speed repetition;
- F** - total odometer.

3

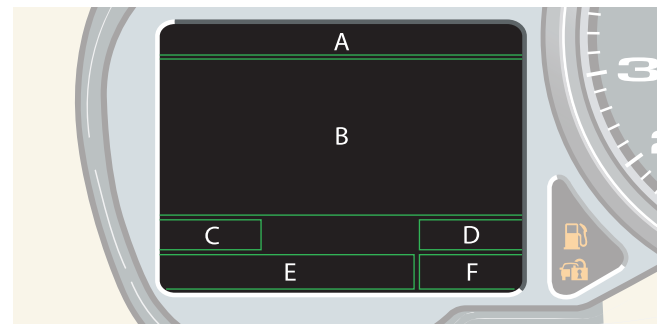



Display setting and configuration of vehicle parameters

Warning



The display settings and parameters must only be adjusted while the vehicle is stationary

MENU screen page

Display setting and configuration of the various vehicle parameters is possible using the MENU screen page (the only screen page in the SETUP group) that can be directly called up by pressing the UP button when the MAIN screen page is activated.

Navigation within the menu is on several levels; the first level offers a list of items through which the following parameters can be set or the following information can be displayed:

- **Dimming**: display dimming setting.
- **Display setup**: display setting.
- **Date/Hour**: date and time setting.
- **Language/M.U.**: language and units of measurement setting.
- **Car setup**: vehicle parameter configuration.
- **Manometer setup**: manometer display setup.
- **Calibr. TPMS**: calibrating the TPMS system.
- **Service**: information on scheduled maintenance.

These items are the main menu functions. To scroll through the list of items, press the UP and DOWN buttons; to select the required function, press and quickly release the OK button or the RIGHT button.

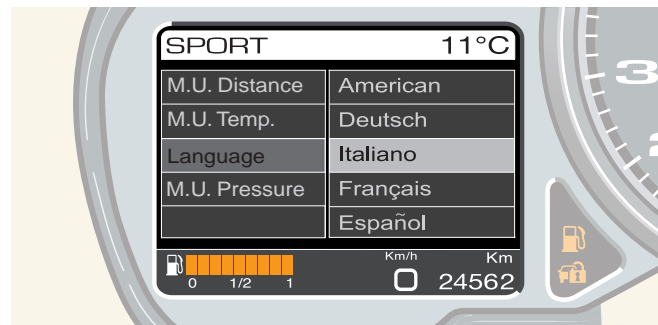
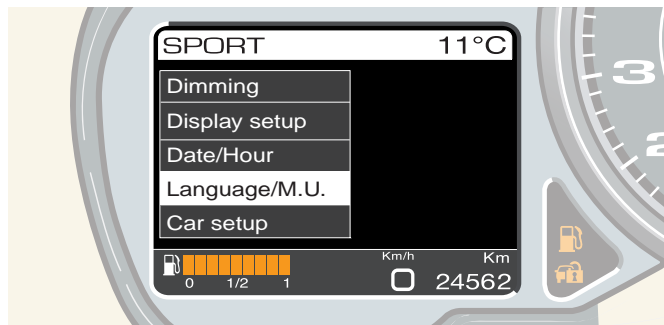



Once the function has been selected, the individual subfunctions or parameters that can be activated are displayed. To select them, use the UP and DOWN buttons and press and quickly release the OK (or RIGHT) button to activate a subsection or activate the selected parameter.

To go back to a previous level in the menu hold down the OK button, press the LEFT button or select the BACK item which is normally in the list of subfunctions. If no operation is performed for at least 10 seconds, the previous menu level reappears on the display.

Adjusting brightness

The brightness setting of the two TFT displays on the instrument panel is adjusted from the specific option in the MENU screen.

3





Fuel level gauge

The fuel level gauge is always displayed in area **D** of the display (see page 131). The gauge has 9 yellow bars that gradually “turn off” as the fuel level drops.



When the second bar goes off, the first bar turns red until fuel runs out.



When the reserve fuel is reached, in addition to the activation of the relative warning lamp on the instrument panel (see page 148), the relative symbol and specific message, together with the remaining range in Km, are shown on the display for 10 seconds. If the condition that has generated it persists, this signal is repeated every 8 km.

In limited cruising range conditions, the information on driving range in km is replaced by the words “Limited cruising range”.

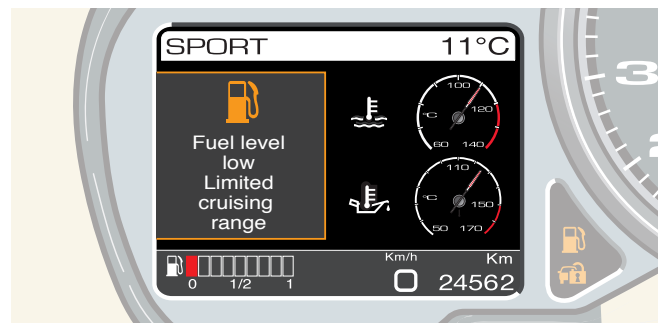
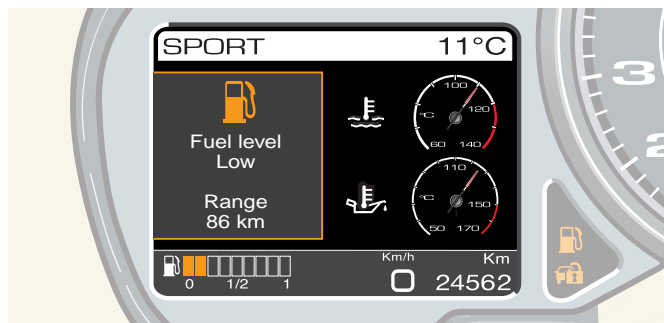



SPORT screen page

The SPORT screen page displays the following gauges:

- Engine coolant temperature.
- Engine oil temperature.

If the SPORT screen page is being displayed and an event occurs that needs to be displayed as a symbol and/or special message, the gauges are minimised. For further information, refer to the “Fault visualisation logic” paragraph on page 146.

SPORT 2 screen page

The SPORT 2 screen page displays the following gauges:

- Engine oil pressure.
- Voltmeter.

If the SPORT 2 screen page is being displayed and an event occurs that needs to be displayed as a symbol and/or special message, the gauges are minimised. For further information, refer to the “Fault visualisation logic” paragraph on page 146.

3

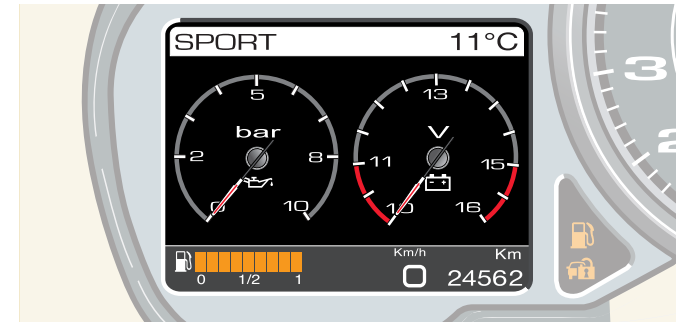
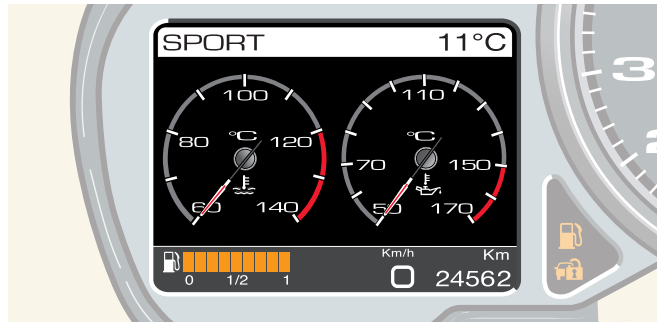



TRIP A and TRIP B screen pages

The TRIP A or TRIP B screen page displays the following information:

- Maximum speed
- Average speed
- Travel distance
- Travel time
- Range

If the TRIP A or TRIP B screen page is being displayed and an event occurs that needs to be displayed as a symbol and/or special message, the screen page is minimised. For further information, refer to the “Fault visualisation logic” paragraph on page 146.

TYRES screen page

The TYRES screen page displays a symbol of the vehicle with the pressure and temperature values for each tyre.

If the TYRES screen page is being displayed and an event occurs that needs to be displayed as a symbol and/or special message, the screen page is minimised. For further information, refer to the “Fault visualisation logic” paragraph on page 146.

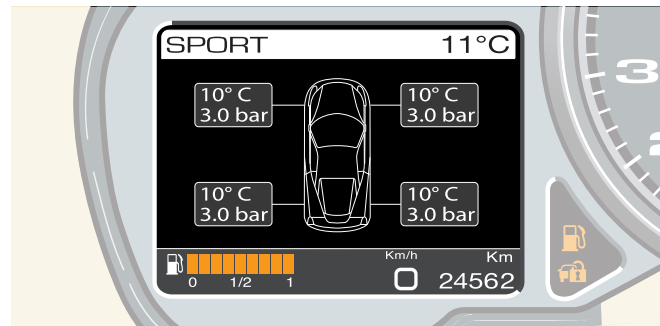
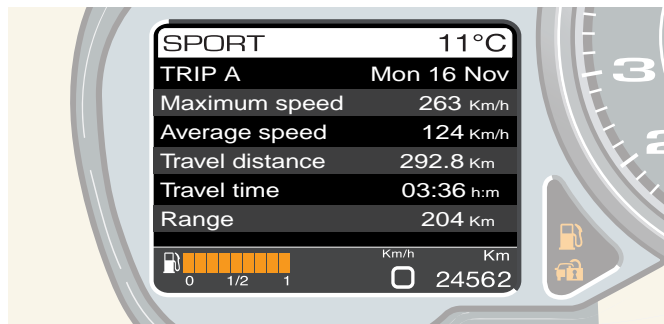



“Warning: danger of ice” display

To warn the driver of the presence of ice on the road if the outside temperature is 3 °C (38 °F) or below, the “snow” symbol and the “warning: danger of ice” message are displayed for 10 seconds in the top right of the display.

When they are displayed, the symbol and message appear instead of the outside temperature; after 10 seconds, the outside temperature is displayed again and the “snow” symbol appears next to it as long as the outside temperature remains 6 °C (43 °F) or below.

“Adaptive Light Control” function display

When a failure in the adaptive light system is detected on a bend, the warning light flashes and at the same time, a message with a special symbol is displayed.

The message is displayed for a set period of time. When this period expires, the screen page disappears but the warning light continues to flash until the situation is corrected.

The next time the engine is started, if the failure persists, the warning light will flash and the same screen page described above will be displayed.

3

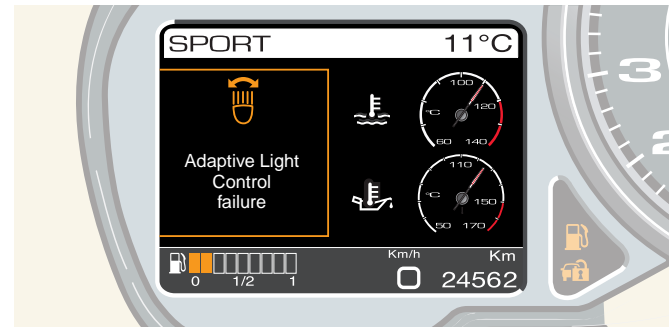
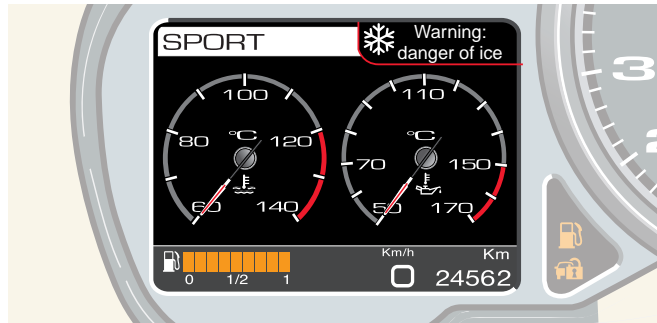



“Speed limit” function display

The MENU screen page can be used to set a speed limit in the range 30 - 250 km/h with 5 km/h steps which sends a message to the driver when exceeded. To set the speed limit, call up the MENU screen page and select the options “Vehicle Config.” and “Speed Limit”.

To set the value, use the **UP** and **DOWN** buttons. When the minimum limit of 30 km/h is reached, press the **DOWN** button again to deactivate the function or press the **UP** button after reaching the maximum speed of 250 km/h. The function is normally deactivated (OFF).

When the set limit is exceeded, the driver is informed in the following way:

The symbol showing the set limit and a “Speed limit exceeded” message appear in the top right of the display for 10 seconds accompanied by an acoustic signal. Once the warning cycle has ended, the message disappears whereas the symbol continues to be displayed next to the outside temperature until the speed decreases to 5 km/h below the set limit.

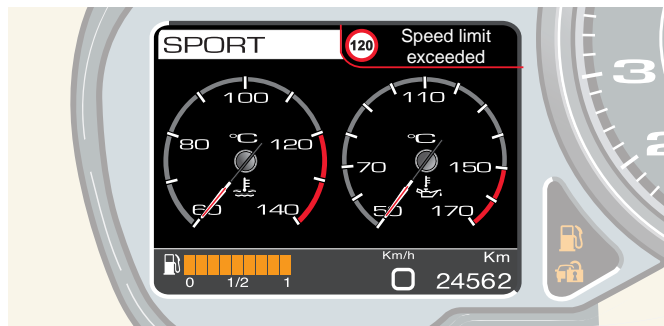

“Doors/Engine or luggage compartment lid open” function display

When the doors and the engine compartment or luggage compartment lid are open, this is signalled by a screen page in which the doors/lids which are open at the same time are highlighted.

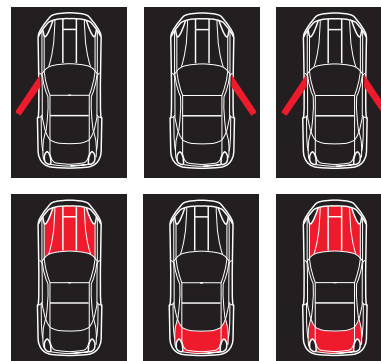
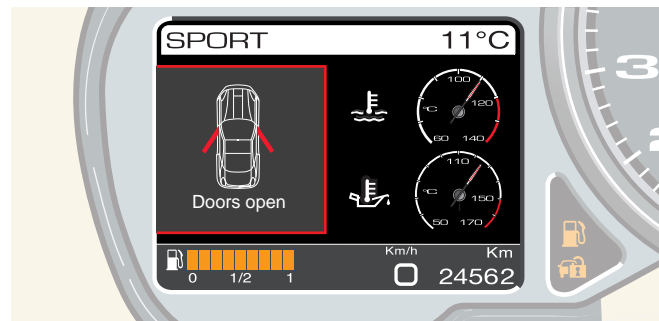



“Tyre pressure and temperature” display

The screen page showing the pressure and temperature values of each tyre can be accessed using the “Display” button.

When the on-board instrument panel receives the signal from the tyre pressure ECU that the pressure level of one or more tyres is below the alarm threshold, a different screen page will appear according to whether the value is low on one or more tyres.

Refer to the “Tyre pressure and temperature monitoring system” section on page 71.

“Tyre puncture” display

When the pressure level of one or more tyres is below the alarm threshold, regardless of the current display configuration, the warning light comes on permanently and a message and special symbol are displayed for vehicles fitted with normal tyres and one for those fitted with Run Flat tyres.

Refer to the “Tyre pressure and temperature monitoring system” section on page 71.

3

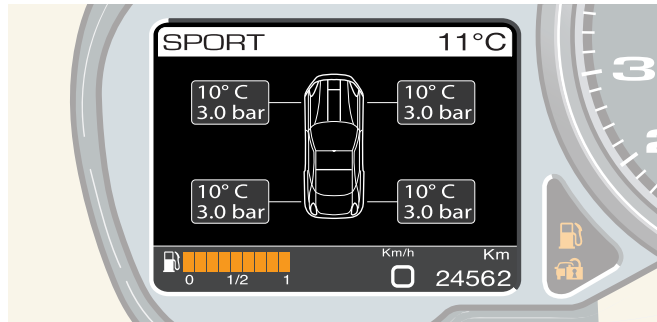



External lights failure display

The following failures can be displayed:

- 1 Stop lights failure
- 2 Number plate lights failure
- 3 Rear fog lights failure
- 4 Running lights failure (front and/or rear)
- 5 Turn indicators failure (front and/or rear).

If one of these failures occurs, a specific message that highlights the faulty light is displayed.

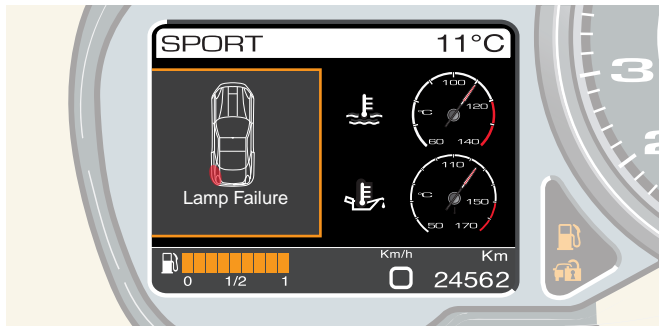



Parking sensors

To help the driver when parking, the vehicle is fitted with four sensors in the rear bumper (rear parking sensors). The vehicle can be fitted on request with four sensors in the front and rear bumpers (front and rear parking sensors).

Warning



The system will only operate correctly if the sensors on the bumpers are free of mud, dirt, snow or ice.

When approaching obstacles in front of or behind the vehicle, the parking sensors inform the driver of the distance between the vehicle and the obstacle by way of acoustic signals, which become more frequent as the obstacle approaches, and visual signals in area **B** of the TFT display (see page 131). By supplementing the driver's direct visual information with that provided by the system acoustic signals and visual warnings, potential collisions can be avoided when parking.

Warning



It is the driver, however, who holds full responsibility for parking manoeuvres and other potentially dangerous situations. The system has only been designed as an aid during parking manoeuvres, since it detects obstacles that are outside the driver's range of visibility.

Use of the sensors therefore does not mean that the driver can be less careful and attentive and not watch out for persons and obstacles during parking manoeuvres.

The rear parking sensors are automatically activated when the key is in position **II** and reverse gear is engaged. When the rear sensors are activated, an acoustic signal warns the driver that the system has been activated. If the vehicle is also equipped with front sensors, these can be activated or deactivated by pressing the relative button on the roof panel (see page 158).

Important note



If the distance between the vehicle and the obstacle (see page 123) is less than 400 mm, the parking sensors will not allow the retractable hard top to be opened or closed.

3

“Stop and Go” function

The “Stop & Go” function, available on vehicles with front and rear parking sensors, automatically activates the front sensors when vehicle speed is 10 km/h or below. This system has been designed to assist the driver in certain traffic conditions (e.g. tailbacks) and signals when the minimum distance is reached between the vehicle and the vehicle in front.

To activate or deactivate the system, call up the MENU screen page, select the items “Car setup”, “Parking sensor”, and select one of the two options, “STOP&GO ON” and “STOP&GO OFF”.

Indication of obstacles

The parking sensor system emits acoustic signals as soon as an obstacle is detected which become more frequent as the obstacle approaches. The acoustic signal stops immediately if the distance from the obstacle increases whereas the tone cycle remains constant if the measured distance from the central sensors remains unchanged.



The vehicle symbol and sensor detection zones appear on the TFT display: these zones indicate which part of the vehicle is approaching an obstacle (if front or rear and if left, right or central) and the distance from the obstacle (maximum, medium or minimum).

If an obstacle is detected at maximum distance in the central front part, it will be displayed as shown below (green).

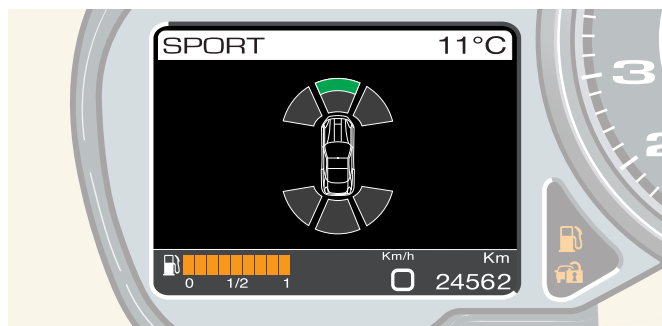

If an obstacle is detected at medium distance in the central front part, it will be displayed as shown below (orange).

If an obstacle is detected at minimum distance in the central front part, it will be displayed as shown below (red).

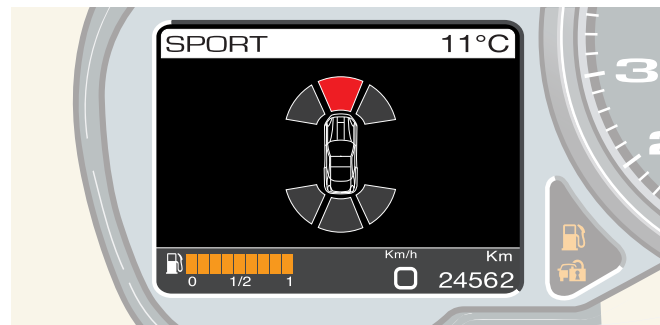
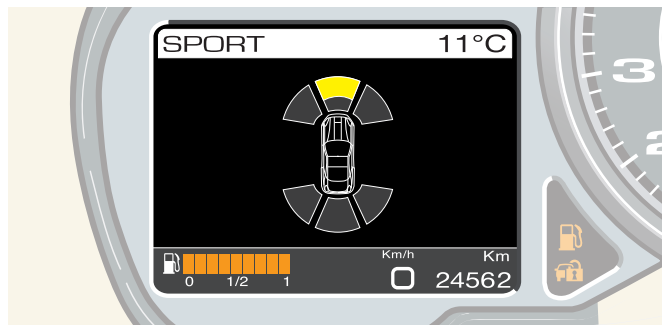



If the front sensors are deactivated or not present, the display does not show the symbols in the front. In the same way, if front sensors are fitted and the rear ones are not activated, the display only shows the symbols in the front. If all the sensors are activated, the system can give several pieces of information at the same time: if an obstacle is detected at a maximum distance in the front central part and at a minimum distance in the rear right part, it will be displayed as shown below.

If the parking sensor system symbols are being displayed and an event occurs that needs to be displayed as an icon and/or special message, the symbol is moved from the centre of the display to the right as shown below.

Important note



If there is a higher priority failure such as a tyre puncture, the TFT display will indicate this failure and the parking sensor symbols will disappear.

3

Once the failure has been displayed, the parking sensor symbols will go back to the centre of the display.

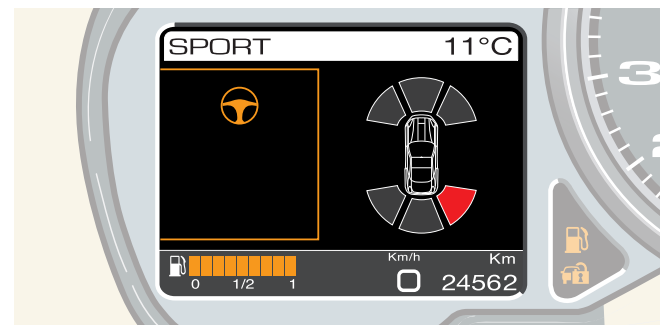
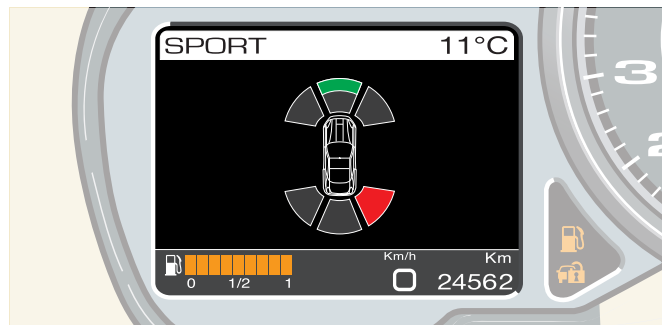



Simultaneous display of parking sensors and other systems

If other systems are activated when the parking sensors are being displayed, the TFT display displays the sensors on the right of the screen and the other active system on the left.

If the hard top is operated, the parking sensor display is deactivated as the sensors will be detecting obstacles that may damage the luggage compartment.

Cleaning the sensors

When cleaning the sensors, be very careful not to scratch or damage them and avoid using dry, rough or hard cloths.

The sensors must be washed with clean water and car shampoo added if necessary.

In car washes that use steam jet or high pressure water cleaning equipment, quickly clean the sensors keeping the nozzle at a distance of over 10 cm.

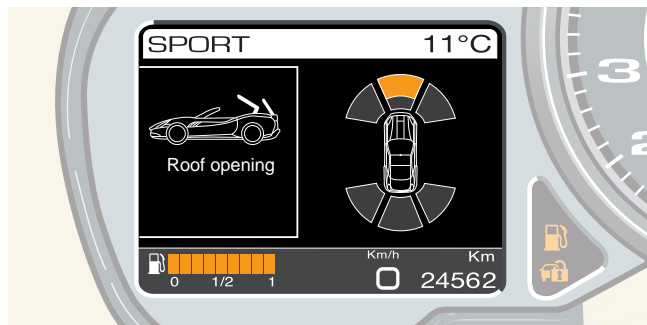

For the repainting of bumpers or retouching the paintwork in the sensor area, contact the FERRARI SERVICE NETWORK. If paint is applied incorrectly, it may jeopardise proper operation of the parking sensors.

Sensing range

The sensors allow the system to control the rear and front of the vehicle: their position covers the central and side areas of the vehicle.

If an obstacle is in the central area, it is detected at distances of approximately 1.40 m depending on the type of obstacle and its size.

If an obstacle is in the side area, it is detected at distances of less than 0.8 m.

Failure signals

The system ECU checks all the components each time the reverse gear is engaged.

A parking sensor system failure is indicated on the TFT display.

If there is a failure signal, stop the vehicle and turn the ignition key to position **0** (Stop). Then try and clean the sensors or move them away from any sources of ultrasound emissions (e.g. pneumatic brakes of lorries or pneumatic drills) and turn the ignition key to position **II** again. In this way, if the cause of malfunctioning has been corrected, the system will start operating correctly again and the failure buzzer will stop.

If the failure buzzer continues, contact the FERRARI SERVICE NETWORK to have the system checked.



Important note



Obstacles that may damage the luggage compartment (obstacles at distances of less than **400 mm**, see page 123) are detected only once by the rear sensors prior to hydraulic operation of the hard top. Any obstacles that appear after hard top activation will not be detected.

Important note



The sensors are able to detect obstacles with reasonably large, even surfaces (e.g.: poles with diameters of over 60 mm, walls, barriers, trees). Detection is not optimum with obstacles with sharp projections or uneven surfaces.

Important note



When parking and operating the retractable hard top, always be very careful to avoid obstacles that may be above or below the sensors.

Important note



Objects placed close to the rear part of the vehicle are not always detected by the system and may therefore damage the vehicle or be damaged themselves.

Important note



The signals sent by the sensors may also be affected by damage to the sensors caused by dirt, snow or ice on the sensors or by ultrasound systems (e.g.: pneumatic brakes on lorries or pneumatic drills) in the vicinity.

Warning



However, the driver has full responsibility for parking manoeuvres and in other potentially dangerous situations. The system has been designed only as an aid during parking manoeuvres and the operation of the retractable hard top, since it detects obstacles that are outside the driver's range of visibility.

The sensors are therefore not a substitute for the driver's care and attention when parking and checking for the presence of persons or objects.

3



Fault display

Fault visualisation logic

When a fault occurs, the corresponding warning light (if present) comes on on the panel whereas a description of the fault (if available) and the relevant symbol (if available) are displayed on the left TFT display. The message appears on the display as soon as the warning light (if present) comes on and the main screen page that is displayed at that time is reduced.

The fault remains on the display for 20 seconds. When the display cycle ends, if the fault does not have a special warning light on the panel, the symbol remains minimised in area **D** of the display (see page 131) until the cause of malfunctioning has been resolved. In area **B** the main screen page is displayed in “maximum” size.

When the display cycle ends, if the fault has a special warning light on the panel, the screen page prior to the anomaly is displayed again, and the symbol is not minimised in area **D**. The warning light on the panel stays on until the cause of malfunctioning has been resolved.

If the fault is resolved within 20 seconds, it remains displayed and the warning light remains lit for 2 seconds.

“ESCAPE” function

Displaying a fault on the screen can be interrupted by pressing and quickly releasing the OK button with “ESCAPE” function. When the OK button is pressed, the screen page that was displayed prior to the event reappears. If the fault does not have a special warning light on the panel, the symbol remains minimised in area **D** until the cause of malfunctioning has been resolved.

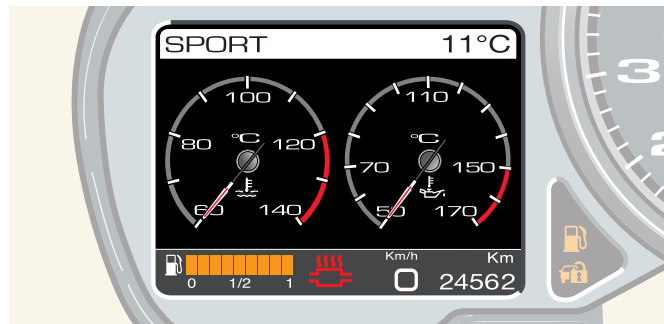
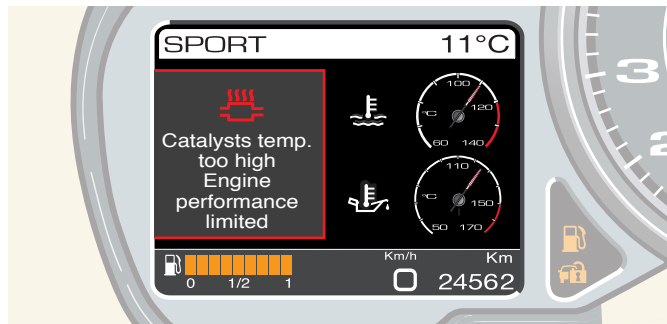



Fault priority levels

The simultaneous display of several faults follows a logic that depends on the priority level assigned to it.

Priority level 0 - Extremely critical fault.

Priority level 1 - Critical fault.

Priority level 2 - Non-critical fault.

When several fault events occur at the same time, faults with priority level 0 are displayed first, followed by priority level 1 and then priority level 2. The information on the various faults is displayed in turn for 5 seconds each. In any case, the total display time for each fault is never less than 20 seconds.

If a fault message with priority level 1 or 2 is being displayed, and a new anomaly with the same priority level occurs, the last fault message is only displayed after the first fault message has been displayed for at least 2 seconds. If, on the other hand, another new priority level 0 fault occurs, this is displayed immediately.

Indication of failure of turn indicators and running lights





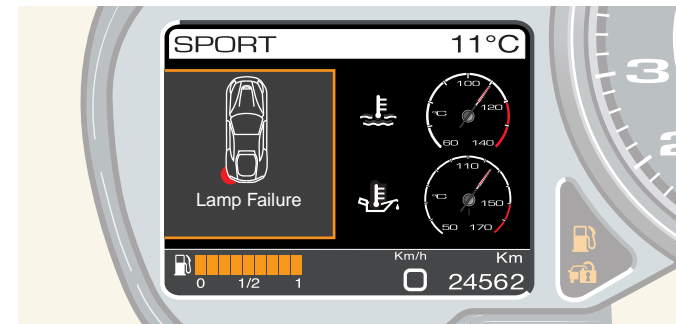



A failure of the running lights (front and/or rear) and turn indicators (front and/or rear) is indicated in the same way as other faults but the vehicle symbol with the faulty running light or turn indicator indicated in red is displayed together with a description of the failure instead of the “External lights failure” symbol (see page 149). When the display cycle ends or the OK button with “ESCAPE” function has been pressed, the “External lights failure” symbol is minimised.











3





List of TFT display symbols and instrument panel warning lights

TFT	Warning light	Description and warnings
	 orange	Alarm system failure Indicates a fault in the alarm system (priority level 1). The system is not programmed (priority level 2). Failure and system not programmed (priority level 1). Alarm system failure (priority level 2). Break-in attempted (priority level 2).
Contact the FERRARI SERVICE NETWORK.		
	 orange	Fuel level low Indicates that the fuel level is too low (priority level 2).
	 red	Battery conditioner connected When the instrument panel is on, it indicates that the battery conditioner is connected (priority level 0).
	 orange	Inertia switch Indicates activation of the inertia switch following an accident and the resulting cut-out of the fuel supply (priority level 0).
The hazard warning lights are also automatically activated.		

	 red	Alternator failure If the recharging system is faulty. When the battery is insufficiently charged or overcharged (flashing).
	 orange	Oil temperature Indicates that the oil temperature is too high (priority level 0).
	 orange	Adaptive light system failure Indicates an adaptive light system failure (priority level 2).
	 red	Engine coolant temperature Indicates that the engine coolant temperature is too high (priority level 0).
Turn off the engine and contact the FERRARI SERVICE NETWORK.		
	 red	Oil pressure Indicates that the oil pressure is too low (priority level 0).
Turn off the engine and contact the FERRARI SERVICE NETWORK.		
Indicates a pressure sensor failure (flashing) (priority level 2).		



orange



Engine diagnostic system (EOBD) failure

While the engine is running, it indicates a fault in the emission control system and in the ignition/injection system.

After turning the ignition key to position II, it remains on for a self-check for a few seconds after the engine has started.



green



Cruise Control

Indicates that the Cruise Control has been activated/deactivated.



green

Running lights

Indicates that the running lights or low beam lights are on.



orange

Stop lights failure

Indicates a system failure or blowing of the STOP light bulb (priority level 2).



orange

External lights failure

Indicates a system fault or blowing of a bulb in the running, turn indicator or rear fog lights (priority level 2).



orange

Number plate lights failure

Indicates a system failure or blowing of the number plate light bulb (priority level 2).



orange

Rear fog lights

Indicates a rear fog light failure.



orange

Twilight sensor failure

Indicates a twilight sensor failure (priority level 2).



red

Hard top failure

Indicates a failure in the retractable hard top (priority level 0).

The type of failure is specified by a special message on the display.



blue

High beams

Indicates that the high beam lights are on.

The light also comes on when flashing.



green

Right turn indicators

Indicates that the right turn indicator is on.



green

Left turn indicators

Indicates that the left turn indicator is on.



green

Hazard warning lights

Simultaneous switching on of the right and left turn indicator warning lights indicates that the hazard warning lights are on.



red

Catalytic converter temperature

Indicates that the catalytic converter temperature is too high: stop the vehicle (priority level 0).

Contact the FERRARI SERVICE NETWORK.



orange

Indicates that the catalytic converter temperature is very high: reduce speed until the symbol goes out (priority level 1).

Indicates a failure in the catalytic converter temperature sensor (priority level 0).

Checking the engine oil level

Indicates a low engine oil level.



orange

Seat heating

Indicates that the seat heating function is activated (front RH/LH) (remains displayed for 5 seconds).



orange

Power steering failure

Indicates that the power steering system is inefficient (priority level 2).



orange

Contact the **FERRARI SERVICE NETWORK**.

Low windscreen washer fluid level

Indicates a low level of washer fluid in the windscreen washer tank (priority level 2).



orange

ABS

Indicates an ABS system failure (priority level 1).



orange



orange

The standard braking system is still functioning.
Contact the **FERRARI SERVICE NETWORK**.



orange



orange

ESC off

Symbol and warning light indicate that the ESC system has been deactivated (priority level 1).

The symbol is displayed for 5 seconds together with the “ESC off” message.



orange



orange

ESC system failure

Indicates a fault in the ESC system (priority level 1).

Warning

Stop the vehicle avoiding sharp braking. Stop driving and contact the **FERRARI SERVICE NETWORK** immediately.

Warning

The vehicle can still be driven at low speed (max. 40 km/h) to clear the road.



orange

ESC system activation (flashing warning light)

Indicates that the ESC system has been activated (priority level 1).

CCM brake discs worn

Indicates that the carbon ceramic discs are worn (priority level 2).



orange

Contact the **FERRARI SERVICE NETWORK**.



orange



orange

TPMS

Indicates a puncture in one or more standard tyres (priority level 0) or Run Flat tyres (priority level 2).

With the warning light in flashing mode for a maximum of 90 seconds after which it remains on in fixed mode, it indicates:

A failure in the TPMS (priority level 2).

TPMS temporarily inactive (priority level 2).



red



red

Airbag system failure (flashing warning light)

Indicates a system failure (priority level 0).

Contact the FERRARI SERVICE NETWORK.



red

Driver-side seat belt not fastened

Indicates that the driver-side seat belt has not been fastened (priority level 0) together with an acoustic signal lasting 90 sec.



red



red

Passenger-side seat belt not fastened

Indicates that the passenger-side seat belt is not fastened (priority level 0).



red

Speed limit exceeded

Indicates that the speed set by the driver has been exceeded (priority level 2), the figure shown indicates the set speed.



red



red

Brake malfunction

Indicates that the brake fluid level is low (priority level 0).

Indicates an EPB (electric parking brake) failure (priority level 0).

Indicates an overhaul of the Parking Brake system (priority level 0).



red



red

Indicates an EBD system failure (priority level 0).



orange



orange

Rain sensor failure

Indicates a rain sensor failure (priority level 2).



orange

Suspension control system failure

Indicates a malfunction in the suspension control system (priority level 2).

Contact the FERRARI SERVICE NETWORK.



orange

Generic failure

Indicates an airbag warning light failure (priority level 2).

Indicates a Manettino failure (priority level 1).

Indicates that the electrical system is faulty (priority level 2).



green

TPMS

Indicates that calibration of the TPMS has been activated.



red

Brake pad wear

Indicates excessive wear of the brake pads (priority level 2).



orange

Parking sensor failure

Indicates that the parking sensor system is faulty (priority level 2).



green

Scheduled Maintenance (Service)

Indicates the Scheduled Maintenance deadline.



orange

AVH system

Indicates an AVH system failure (priority level 0).



red



red

Parking brake

Indicates that the parking brake is applied.



Ice hazard

Indicates that the outside temperature is 3 °C (38 °F) or lower, highlighting the risk of icy road surfaces.

Drive carefully in these conditions and slow down since tyre grip is significantly reduced.

Warning



In this condition, do not activate the "SPORT" mode.



red



red

Gearbox failure

Indicates a system failure (priority level 1).

Contact the **FERRARI SERVICE NETWORK**.



Electronic speedometer

It indicates the vehicle speed.

At a speed between 0 and 5 km/h, the indicator may remain idle.
With higher speeds, it indicates the speed measured.

Rev Counter

The electronic rev counter indicates the engine RPM. Avoid engine speeds in the red sector.

Gearbox display

The display which gives information on dual clutch transmission (DCT) is found to the bottom right of the rev counter; with the ignition key in position II, it displays the following information:

- Gear engaged.
- Indication of “Automatic gearbox” mode.
- Indication of “Auto easy exit gearbox” mode.
- Indication of gearbox in “Parking” mode.
- Indication of Launch Control activated.
- Indication of AVH system activated.

3

Important note



Information on the gearbox is useful in all operating conditions.





Gear engaged

The gearbox display shows the number or letter indicating the engaged gear in the centre.

N	Neutral
R	Reverse
1	1 st gear
2	2 nd gear
3	3 rd gear
4	etc.

When the key is turned to off, the display remains on for at least 3 seconds and displays the engaged gear. If the control panel reads N (Neutral), the letter N is displayed and a buzzer will sound.

Indication of “Automatic gearbox” mode

When the gearbox is used in “automatic” mode (see page 172), the word “auto” appears in the bottom of the gearbox display together with the number or letter indicating the engaged gear.

Indication of “Auto easy exit” mode

When the gearbox is used in “Auto easy exit” mode (see page 172), the word “auto” appears in the bottom of the display together with a small “arrow” pointing downwards on the left.

Indication of gearbox in “Parking” mode

When the gearbox is in “Parking” mode, i.e. the Park Lock gearbox locking device is activated (see page 179), the letter “P” appears in the centre of the gearbox display.

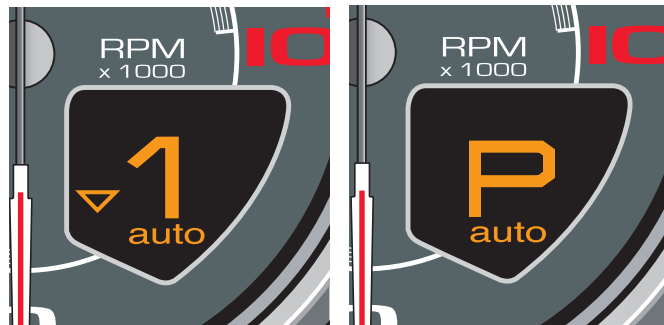
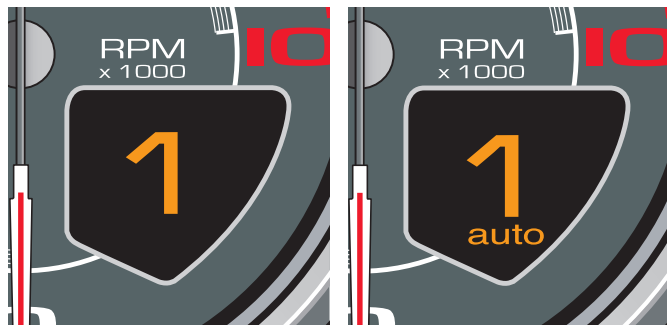



Indication of Launch Control activated

When the gearbox is used in “manual” mode and the Launch Control function is requested by pressing the special button on the centre console (see page 180), the word “launch” appears in the bottom of the gearbox display. The word remains while the function is activated.

Indication of AVH system activated

In certain circumstances, when the AVH system is activated (see page 184), the word “HOLD” appears in the top of the gearbox display.

3

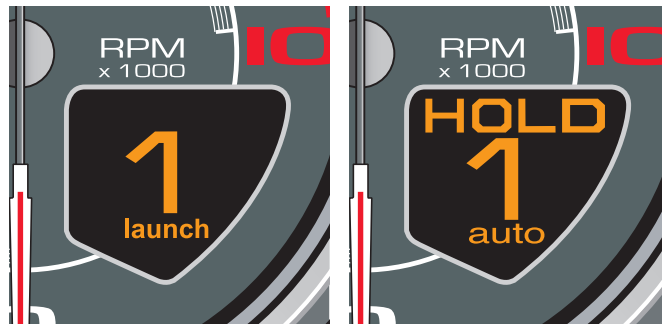



Turbo Performance Engineer (TPE) display

The TPE display can be activated by pressing the touch-sensitive ring for 3 seconds. Each time it is pressed, it cyclically passes through its 5 functions: time displayed in 12-hour format, external temperature displayed in degrees Celsius or Fahrenheit, pressure reading of turbo in bar or psi, and two screens that display the main characteristics of the turbo engine.

- **TURBO**: indicates the working pressure of the turbocharger in bar or psi.
- **TURBO EFFICIENCY (TE)**: indicates the percentage of maximum turbo efficiency (seen as the maximum torque obtainable by the car for a given fuel consumption level or specific amount of fuel used) available to the driver depending on the number of revs.

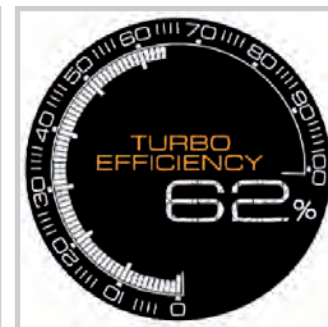



- **TURBO RESPONSE (TR)**: indicates the percentage of maximum engine response available to the driver depending on the number of revs. For instance, using the gearbox and accelerator pedal to push the engine to over 4000 RPM gives a very high % of TR (80-90%): pressing the accelerator pedal hard down will give instant engine response and acceleration.

- **Time**: displays a 12-hour format digital clock.
- **External temperature**: displays a digital thermometer, the temperature can be displayed in degrees Celsius or Fahrenheit.

3

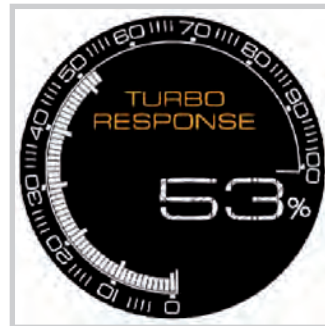



Roof panel controls

Door lock/unlock

Both doors can be locked by activating/deactivating the “LOCK/UNLOCK” **H** button. For further information, see page 86.

Deactivating the anti-lift alarm

Press button **L** to deactivate the anti-lift alarm system. For further information, see page 18.

Front parking sensors (optional)

On vehicles fitted with front and rear parking sensors, the front parking sensors are activated/deactivated by pressing button **M**. When the front parking sensors are activated, the light on the button comes on.



Horn control

The horn can be used by pressing the horn symbol, on either side of the steering wheel upper spokes.





Controls on the steering wheel

Start button

Press the ENGINE START button **A** to start the engine. When the engine has started, release the ENGINE START button.

Do not hold the ENGINE START button down for a long time.

Driving mode control switch “Manettino”

The driving mode selected does not exempt the driver from complying with the rules of safe driving.

The driver can select the driving mode using the “Manettino” **B**, according to the desired driving style.

Important note



In the event of a failure of one of the onboard systems, signalled by the relative warning light on the TFT display, the switch moves to a “recovery” position, but still allows the vehicle to be driven. In these cases, contact the FERRARI SERVICE NETWORK.

3





Driving modes that can be selected with “Manettino”

COMFORT mode

This is recommended for everyday driving.

SPORT mode

This is the ideal setting for vehicle performance.

Select **SPORT** mode for sports-style driving, under high-grip conditions.

Activation will be signalled by the **SPORT** icon in the dedicated area on the TFT display.

ESC OFF mode

Select this mode to deactivate the ESC system (always active when the engine is started).

When the system has been deactivated, a warning light comes on on the instrument panel (see page 150); the symbol appears on the TFT display for 5 seconds together with the “ESC off” message.

When the ESC system has been activated, a warning light flashes on the instrument panel (see page 150).

Warning



In low- to medium-grip conditions (e.g. wet, icy, sandy roads), do not deactivate the **ESC** system and do not select **SPORT** mode.

Important note



When “ESC OFF” mode is selected, the Manettino lever automatically goes back to “SPORT” mode: this occurs because each time the engine is started, the ESC system is reactivated.

Important note



When the brake pedal is pressed, traction control is activated via the VDC system (vehicle dynamics control via the braking system).



“UP” shift paddle

Pull the right-hand **UP** paddle towards the steering wheel to shift gears up.

“DOWN” shift paddle

Pull the left-hand **DOWN** paddle towards the steering wheel to shift gears down.



Windscreen and headlight washer/wipers

Important note



The windscreen wipers and washer work only with the ignition key in position II.

The windscreen wipers have 4 different speeds:

OFF Windscreen wipers stationary.

AUTO The rain sensor adjusts the windscreen wiper timing to the intensity of the rain.

1 Slow continuous operation.

2 Fast continuous operation.

With the wipers stationary (**OFF**), quickly pressing lever **A** towards the dashboard activates the windscreen wipers in **AUTO** speed.

With the wipers on, quickly pressing the lever towards the dashboard increases windscreen wiper speed (from **AUTO** to **1**, from **1** to **2**).





Windscreen washer

To activate the windscreen washer, keep lever **A** pulled.

When the lever is released, the windscreen wiper returns to the preset speed.

Warning



Do not start the windscreen washer during the cold months until the windscreen has warmed up. If it has not warmed up, the fluid could freeze on the glass and block the view.

Headlight washer

The headlight washer is activated automatically when the windscreen washer is operated and the low beams are on. The headlight washer and windscreen washer share the same fluid tank and a low fluid level is indicated by the relative symbol on the left TFT display.

Rain sensor

The rain sensor automatically adjusts the windscreen wiper timing to the intensity of the rain. The system is activated by moving the windscreen wiper to **AUTO**.

When operating automatically, the wiper speed ranges from a minimum intermittent setting (one wipe every 5 seconds approx.) when the windscreen is damp to fast continuous operation in heavy rain.

Important note



The rain sensor function is deactivated by turning the ignition key to position **0** and leaving the windscreen wiper in position **AUTO**. To reactivate the system at the next key-on, set the wipers to **AUTO** by quickly pressing the lever **A** towards the dashboard.

Warning



Before cleaning the front windscreen (for example in service stations) make sure the rain sensor is deactivated or that the key is in position **0**. The rain sensor must be deactivated also when washing the vehicle by hand or in automatic car washes.

In case of ice or snow on the front windscreen, do not activate the rain sensor to avoid damaging the wiper motor and/or blades.

Rain sensor failure

If there is a rain sensor failure, indicated by a special symbol on the left TFT display (see page 151) while the windscreen wiper is set to **AUTO**, the wipers will be set to intermittent operation with one wipe every 1 second approximately. If this is the case, we recommend that you deactivate the rain sensor and turn on the wipers, if necessary, in continuous mode.

Important note



If this occurs, contact the **FERRARI SERVICE NETWORK** as soon as possible.



Cruise control

The Cruise Control is an electronic device designed to help the driver drive at a constant speed of over 50 km/h without having to keep the accelerator pedal pressed.

Important note



We recommend only using the device on long, dry stretches of road requiring few gear changes (e.g. motorways).
Do not use the device for city driving.

Important note



PIT SPEED is a term taken from the motor sports world used by **FERRARI** to indicate the speed memorised using the device and does not endorse inappropriate behaviour on the road which does not comply with Traffic Regulations.



Activating the device

To activate the device, hold down control **A** for at least 2 seconds.

When the system is activated, a warning lamp lights on the instrument panel (see page 149), and the message “Cruise Control ON”, together with the specific symbol, are shown for 5 seconds on the left hand TFT display.

The device cannot be activated when reverse or 1st gear are engaged.

When going down slopes with the device on, the vehicle speed may be slightly higher than the memorised speed.

Memorising the speed

Proceed as follows:

- with the device activated, bring the vehicle to the desired speed by pressing the accelerator pedal;
- turn control **A** clockwise (+) for at least 3 seconds and then release it: the speed of the vehicle is memorised and you can release the accelerator pedal.

If necessary, you can accelerate by pressing the accelerator pedal: when the pedal is released, the vehicle will return to the previously memorised speed.



Resetting the memorised speed

If the device has been turned off by pressing the brake pedal, the memorised speed can be reset as follows:

- gradually accelerate until the vehicle reaches a speed which is close to the memorised speed;
- quickly press control **A**.

Increasing the memorised speed

This can be done in two ways: by pressing the accelerator and memorising the new speed reached or by turning control **A** clockwise (+).

One turn of the control corresponds to an increase in speed of about 2 km/h; if the control is kept turned on the other hand, the speed continually increases.

Reducing the memorised speed

This can be done in two ways: by deactivating the device and then memorising the new speed or by turning control **A** counterclockwise (-).

One turn of the control corresponds to a decrease in speed of about 2 km/h; if the control is kept turned on the other hand, the speed continually decreases.

Deactivating the device

Hold down control **A** for at least 2 seconds or turn the ignition key to position **0**. The device is also automatically deactivated by pressing the brake pedal.

When it is deactivated, the warning light on the instrument panel goes out and a “Cruise Control OFF” message accompanied by a special symbol appears on the left TFT display for 5 seconds.

Warning



While driving with the device activated, do not put the vehicle into “N” (neutral).



Driving the vehicle

Running-in

The latest manufacturing techniques have allowed us to achieve high precision and accuracy levels in the construction and assembly of components. Nonetheless, the vehicle movable parts undergo a settling process, basically during the first hours of operation.

Engine and transmission

Avoid exceeding 5,000 RPM for the first 1,000 km.

After starting, do not exceed 4,000 RPM until the engine has warmed up (oil temperature: 65-70 °C / 149-158 °F).

Do not let the engine run at a constantly high speed for a prolonged time.

Warning



BEFORE YOU DRIVE

Check that the seat belts are fastened.

Check that the doors are closed.

Check that the seat is properly adjusted.

Check the rear-view mirror adjustment (central and sides).

3



Before a trip

Preliminary checks

Check the following at regular intervals and always before long trips:

- tyre pressure and condition;
- levels of fluids and lubricants;
- condition of the windscreen wiper blades;
- proper functioning of the warning lights and external lights.

Important note



In any case, it is advisable to perform these checks at least every 1000 km and always comply with the maintenance schedule.

It is also advisable to:

- clean the glass covers of the external lights and all the glass surfaces;
- properly adjust the mirrors, steering wheel, seats and seat belts.

Refilling

Warning



Use unleaded fuel only!

Using leaded fuel would permanently damage the catalytic converters.

For specifications and quantities of lubricants and fluids, refer to the “Refilling” table on page 36.



Starting and driving the vehicle

System start-up

After turning the ignition key to position II (key-on), the TFT display is activated on the instrument panel and system diagnosis is performed. During diagnosis, which lasts 5 seconds, a check is performed on the warning lights on the panel and the presence of any faults is checked.

If diagnosis detects any errors, they are only displayed once the 5 seconds required for the check have elapsed. The cases listed below are an exception and errors are displayed as soon as the key is turned to on, even during diagnosis:

- Low engine oil pressure (see page 148).
- Inertia switch triggered (see page 148).
- Semi-automatic gearbox safety warnings.
- Deactivation of EPB warning (see page 183).

If the next scheduled maintenance deadline is approaching, each time the key is turned to on, information on scheduled maintenance is automatically displayed after diagnosis. For further information, refer to the "Maintenance Schedule" paragraph on page 252.

Finally, each time the key is turned to on, the message for activation of the alarm when an intrusion has been attempted (see page 19) is also displayed (after diagnosis).

Once the system check has been completed, the gearbox display is activated and the letter "P" (Parking) or "N" (Neutral) will be displayed.

Important note



BEFORE YOU DRIVE

If the warning light **A** does not turn off after diagnosis, indicating a fault in the gearbox (which is also indicated by the symbol and specific message on the TFT display - see page 152), CONTACT THE FERRARI SERVICE NETWORK.

3





Important note



The vehicle is equipped with an electro-hydraulically controlled gearbox system operated by means of paddles on the steering wheel.

The default setting for the DCT gearbox is always “Automatic” mode (see page 172).

Every time the vehicle is started, the DCT gearbox is in “Auto easy exit” mode (see page 172) unless the vehicle was in “Automatic” mode when the engine was turned off.

To exit the “Auto easy exit” mode operate the **UP** and **DOWN** paddles (while the vehicle is moving) or press the **AUTO** button on the centre console.

Important note



Immediately release the **UP** and **DOWN** paddles or button **R** after the gearbox display shows that the gear has been engaged; a prolonged manoeuvre would cause the gearbox failure warning light to turn on (see page 152) and triggering of the buzzer.

Important note



If the engine compartment lid is open or not properly closed, none of the gears can be engaged. When the vehicle is stationary, with the driver-side door open or not properly closed and the brake pedal released, the system disengages the gear engaged after approximately two seconds.





Starting the engine

Before starting the engine, make sure that the alarm system and all electrical devices with high power absorption are turned off.

- Make sure that the electric parking brake is applied and that the doors are closed.
- Hold the brake pedal down when starting the engine.

Warning



Do not press the accelerator pedal.

- Turn the ignition key to position II and wait for the gearbox display to come on.
- Press the **ENGINE START** button (see page 159) and release it as soon as the engine starts.

Do not hold the **ENGINE START** button pressed down for a long time.

If the engine does not start, turn the key back to position 0 and wait for the gear display to go off before retrying.

Warning



Hold the brake pedal down while starting the engine.

If the engine fails to start after several attempts, check for one of the following causes:

- insufficient speed of the starter motor (flat battery);
- ignition device faulty;
- electrical contacts faulty;
- fuel pump fuses blown.

Warming up the engine

Do not run the engine at high speed until the engine oil temperature has reached at least 65-70 °C (149-158 °F), approximately.

Starting the vehicle

With the engine started, the vehicle stationary and the brake pedal pressed, pull the right-hand **UP** paddle towards the steering wheel to engage 1st gear.

Release the brake pedal and press the accelerator to start off.

With the engine running and the vehicle stationary, you can change directly from 1st or 2nd gear to “R” (reverse) by pressing **R** on the centre console and from reverse to 1st by moving the **UP** paddle.





Warning



If the **UP** and **DOWN** paddles are not working, the message “Depress brake pedal and press LAUNCH to engage gear” will appear on the TFT display; you can therefore engage the gear by pressing the **LAUNCH** button on the centre console (see page 180) and the brake pedal.

In these cases, the “Launch Control” function is not available.

If the engaged gear was **R**, the **LAUNCH** button must be pressed twice to engage **1st** gear.

Important note



When reverse is selected, an acoustic safety signal beeps intermittently as long as “R” is engaged.

If the system automatically selects **2nd** gear when attempting to shift from **R** to **1st** gear, this indicates that **1st** gear has jammed. Therefore, this is not a malfunction, as it falls within the system operating logic. For the same reason, when shifting from **1st** gear to “**R**”, the system will automatically engage “**N**” if the gear has jammed.

During prolonged stops with the engine running, it is advisable to keep the gearshift in “**N**”.

Important note



If you allow the vehicle to move forward in **N**, when **UP** or **DOWN** is requested, a gear will be engaged that corresponds to the speed of the vehicle.

UP-shifting

Operate the right-hand **UP** paddle without releasing the accelerator pedal.

An **UP**-shift request is not accepted when engagement of the requested gear forces the engine to underrev or if an **UP**-shift is already in progress because of engine overrevving.

Gearshifting will be much quicker if the request is made with the accelerator pedal pushed right down and the engine at over 5,500 rpm.

In any event, it is advisable to:

- Shift gears without releasing the accelerator pedal if pressed.
- Wait until gearshifting has been completed before requesting the next shift, avoiding a rapid sequence of multiple requests.

UP-shifting due to overrevving

The system “automatically” engages a higher gear if the accelerator pedal is pressed and the engine approaches the “runaway speed rate” (overrevving).

Important note



This will not occur when the system is in “SPORT” and “ESC OFF” driving mode.



DOWN-shifting

Use the left-hand **DOWN** paddle without releasing the accelerator pedal.

A **DOWN**-shift request is not accepted if engagement of the requested gear forces the engine beyond a certain RPM, depending on the gear requested, or if a **DOWN**-shift is already in progress because of engine underrevving.

In any event, it is advisable to:

- Shift gears without releasing the accelerator pedal if pressed.
- If **DOWN**-shifting is requested to start overtaking which requires quick acceleration, press the accelerator pedal just before using the paddle.
- Wait until gearshifting has been completed before requesting the next shift, avoiding a rapid sequence of multiple requests.

DOWN-shifting due to underrevving

- The system shifts down “automatically” if the engine goes below a minimum number of revs (1250 RPM).
- The **DOWN**-shift request from the paddle is ignored if gearshifting is already in progress due to engine underrevving.

“N” (Neutral) request

With the engine running, pull both **UP** and **DOWN** paddles towards the steering wheel at the same time without pressing the brake pedal to request neutral “N”.

If necessary, “N” can be requested at any speed.

Subsequently, if an “**UP**” or “**DOWN**” shift is requested, the system will engage the gear most suited to the speed of the vehicle.

Stopping the vehicle

When the vehicle stops, the system automatically engages 1st gear unless Neutral has already been requested.

When the vehicle is stationary and the engine is running, hold the brake pedal down until ready to move off again.

Switching off the engine

The engine can be switched off with the gearbox either in “N” or with a gear engaged.

After turning the ignition key from position **II** to position **0**, the gearbox display will remain on for a few more seconds to display the engaged gear. If the gearbox is in “N” a buzzer will sound. Before switching off, the letter “P” is displayed on the gearbox display to inform the driver that the Park Lock has been activated.

Warning



Never leave the vehicle with the gearbox in “N”. Always make sure that the letter “P” (Parking) appears on the gearbox display.

Warning



Never leave the vehicle with the engine running.

Important note



If the vehicle is not in Parking mode (the letter “P” must be displayed on the gearbox display), the key cannot be removed.

For information on the Park Lock, see page 179.



“Automatic gearbox” mode

The “Automatic gearbox” mode is enabled/disabled by pressing the **AUTO** button on the centre console. When the “Automatic” mode is enabled, the word “auto” appears on the gearbox display. To exit the “Automatic” mode, you must press the **AUTO** button until the word “auto” on the gearbox display disappears.

When the “Automatic Gearbox” mode is enabled, the system will automatically UP-shift and DOWN-shift according to vehicle speed, engine revs and the torque/power request of the driver.

When you are in “Automatic” mode, you can however manually shift gears using the **UP** and **DOWN** paddles. The system remains in “Automatic” mode: this is indicated by the word “auto” that remains on the gearbox display in flashing mode when the paddles are used.

When the vehicle is stationary, a “N”, 1st gear or “R” request will not result in a change from “Automatic” to “Manual”.



“Auto easy exit” mode

Every time the vehicle is started, the gearbox starts in “Auto easy exit” mode unless it was in “Automatic” mode when the engine was turned off. In this case, it remains in “Automatic” mode the next time the engine is started.

Activation is signalled by the word “auto” and an arrow ▼ in the gearbox display.

In this mode, the system will automatically UP-shift and DOWN-shift according to vehicle speed, engine revs and the torque/power request of the driver.

To exit the “Auto easy exit” mode and go to “Manual” mode, operate the **UP** or **DOWN** paddle (while the vehicle is moving) or press the **AUTO** button on the centre console.

If the “Automatic” gearbox mode is then requested by pressing the **AUTO** button, the system will apply all the characteristics of the “Automatic” gearbox mode.

Push start

Warning



Push starting is not allowed.



Safe driving

For safe driving, it is essential that the driver be aware of the best driving techniques suited to various circumstances. Always try to prevent dangerous situations by driving with caution.

Before you drive

- Adjust the position of the seat, steering wheel and rear-view mirrors, in order to obtain the best driving position.
- Adjust the backrest so that your chest is upright and your head is as close to the headrest as possible.
- Carefully adjust the headrest so that your head, and not the neck, is resting against it. Ensure that nothing (e.g. mat covers, etc.) is blocking the pedals.
- Check that the lights and headlights are working properly.
- Ensure that any child restraint systems (e.g. child seats, cradles etc.) are properly fixed on the passenger seat.
- Your reflexes are quicker if you eat lightly before driving: avoid heavy meals before a trip.
- Do not drink alcoholic drinks before and during the journey.

At regular intervals, check the following:

- Tyre pressure and condition
- Engine oil level
- Engine coolant level and system condition
- Brake fluid level
- Steering fluid level
- Windscreen washer fluid level.

While travelling

- Caution is the number one rule for safe driving, which also means you should take other people's behaviour into consideration.
- Follow the Road Regulations in force in the country you are driving in and always respect the speed limit.
- Always make sure that the driver and passengers have their seat belts fastened and that all children are travelling in suitable child seats.
- Good personal physical conditions ensure you can drive long distances safely.



Warning



Driving under the influence of drugs or certain medications is dangerous to yourself and others as well as contravening road regulations and legal norms.

Travelling without your seat belt fastened increases the risk of serious injury and death in the event of a collision. Always fasten the seat belt and the child seat, if any.

Deactivate the passenger's airbag (where possible) if a child seat is fitted on the front seat.

Do not travel with objects lying around on the floor, especially in front of the driver's seat: in the event of braking, these could slide under the pedals, making it impossible to brake or accelerate.

Additionally, ensure that any loose floor mats sit correctly.

Water, ice and salt spread on icy roads may deposit on the brake discs and reduce the efficiency of the initial braking.

- Make regular stops to loosen up your limbs and refresh yourself and avoid driving for hours on end.
- Keep a constant air circulation in the passenger compartment.
- Never coast downhill with the engine off: in these conditions the engine brake, servo brake and power steering are inefficient, braking requires greater pressure on the pedal and steering will be harder.

Driving at night

When you are travelling at night, follow these fundamental rules:

- Reduce speed, particularly on dark roads.
- Drive with due caution in consideration of the reduced visibility.
- If you start feeling tired or sleepy, stop immediately: to continue driving would be a risk for yourself and for others. Continue only after you have had a rest.
- At night, it is difficult to judge the speed of vehicles in front of you as you can only see their taillights: keep at a greater safety distance than you would during the day.
- Use the high beams only outside of urban areas and when you are sure that they will not disturb other drivers.
- Turn off the high beams when you see oncoming vehicles and use the low beams.
- Keep the lights and headlights clean.
- Watch out for animals crossing the road when travelling outside urban areas.

Driving in the rain

Rain and wet roads can cause hazardous situations.

All manoeuvres are more difficult on a wet road, as the tyres have significantly less grip on the road. This means that the braking distances increase considerably and road-holding decreases.

Here is some advice for driving in the rain:

- Keep a greater safety distance between yourself and the other vehicles and reduce your speed.
- When it is raining very hard, visibility is also reduced. In these cases, to make yourself more visible to others, turn on the low beams even during the day.



- Do not drive through puddles at high speeds since you do not know how deep they may be; Travelling through a puddle at high speed can result in losing control of the vehicle (“aquaplaning”): if this occurs, grip the steering wheel firmly.

Warning



If the road is wet, reduce your speed to avoid “aquaplaning” (during which the tyre no longer touches the road surface. This is due to the fact that, when the road is very wet and vehicle speed is high, because of their particular shape or insufficient depth, the side channels of the tyre tread are not capable of removing all of the water channelled so that a layer of water is placed between the road surface and the tyre. The fluid pressure generated is so high that it supports the vehicle's weight making it virtually impossible for the driver to control the vehicle).

- Use the ventilation system to demist the windscreen (see page 199) and avoid visibility problems.
- Periodically check the condition of the windscreen wiper blades.

Driving in fog

Whenever possible, avoid travelling if there is thick fog. If you have to drive in misty conditions, or if there is thick fog or fog banks, follow these rules:

- Keep a moderate speed.
- Turn on the low beams, also during the day, and use the rear fog light. Avoid using the high beams.

Warning



On stretches where visibility is good, turn off the rear fog light, it may be annoying for the occupants of the vehicles behind you.

- Remember that fog makes the road damp and therefore all manoeuvres are more difficult and braking distances are longer.
- Keep a safe distance from the vehicle in front of you.
- As far as possible, avoid suddenly changing speed and direction.
- As far as possible, avoid overtaking.
- In the event of an emergency stop, (e.g. failures, inability to proceed due to poor visibility conditions, etc.) try to free the main driving lane. Then turn on the hazard warning lights and, if possible, the low beams. On approaching another vehicle, sound the horn rhythmically.

Driving on mountain roads

Below is some advice for driving on steep mountain roads:

- To prevent the brakes from overheating when driving downhill, use the engine to brake by engaging a lower gear.
- Never coast downhill or drive downhill with the engine off or in neutral, nor with the ignition key removed from the steering column.
- Drive at a moderate speeds and do not “cut” corners.
- Remember that overtaking uphill is slower and requires a longer free stretch of road. If you are overtaken when driving uphill, ensure that the other vehicle can pass easily.



Driving on snowy or icy roads

Below is some advice for driving in these conditions:

- Keep a very moderate speed.
- Keep a safe distance from the vehicles in front of you.
- Fit snow tyres approved for the vehicle.
- Given the poor grip, use the engine brake as much as possible and avoid sudden braking.
- Avoid sudden acceleration and sharp changes in direction.
- During the winter season, even apparently dry roads can have icy sections.

Therefore, be careful when driving along stretches of road in the shade as there may be icy patches.

Driving with the “ABS” braking system

The ABS system assists the driver as follows:

- It prevents the wheels from locking and skidding during emergency braking, particularly in low-grip conditions.
- It allows braking and changing direction at the same time. This feature is affected by the physical limits and lateral grip of the tyres.
- When the ABS is activated, you will feel a slight pulsing of the brake pedal during emergency braking or in low grip conditions. Do not release the pedal but continue to push it to give continuity to the braking action.
- The ABS prevents the wheels from locking, but it does not increase the physical limits of grip between the tyres and the road: keep a safe distance from the vehicles ahead and reduce speed before curves.

Power steering system

The power steering system uses the power produced by the engine to help the driver steer more precisely while exerting less force on the steering wheel.

Important note



Remember that power steering does not work when the engine is switched off and more force is therefore needed when steering.

Warning



Do not keep the steering wheel fully turned (locked position) to the right or the left for more than 15 seconds when the engine is running. This may damage the power steering system.

Important note



If the power steering system is not working properly, as indicated by a symbol which appears on the TFT display (see page 150), contact the FERRARI SERVICE NETWORK.



Driving using the driving mode control switch (“Manettino”)

The driving mode control switch **A** on the steering wheel, allows the driver to use the vehicle potential in a quick and easy way.

There are three modes available which can be selected according to the grip level (from low to high) and consequently the level of driving assistance required (from high to none).

- The **COMFORT** mode is recommended for everyday driving.
If COMFORT mode is selected, it is indicated on the TFT display as shown below:

3

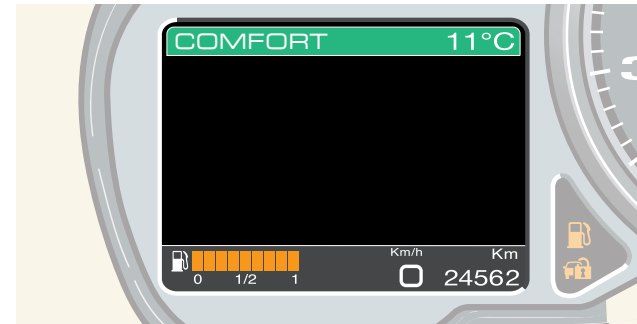



- **SPORT** mode is the vehicle driving mode that provides the best compromise between stability and performance. This setting ensures stability in medium- to high-grip conditions only (for low-grip road surfaces, we recommend using the **COMFORT** mode). In this mode, the vehicle maximum performance can be experienced on open roads. For this reason, the suspension damping level is shifted to a higher one, so as to enhance performance, handling and stability at high speeds.

If SPORT mode is selected, it is indicated on the TFT display as shown below:

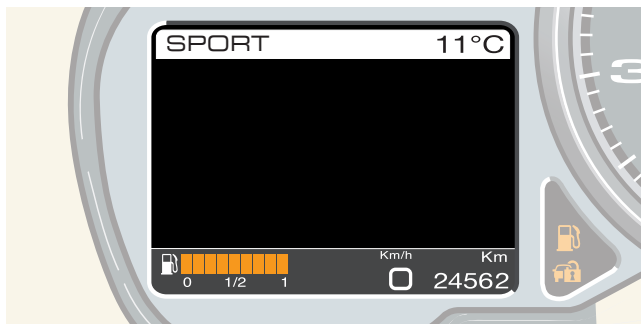

- In “**ESC OFF**” mode the **ESC** system is disabled. Vehicle stability is no longer controlled, but is completely in the hands of the driver. The only auxiliary systems still active are those that cannot be deactivated such as ABS and EBD.

Warning



In low- to medium-grip conditions (e.g. wet, icy, sandy roads), do not deactivate the **ESC** system and do not select **SPORT** mode.

Important note



When the brake pedal is pressed, traction control is activated via the VDC system (vehicle dynamics control via the braking system).

When the ESC system has been deactivated, it is indicated on the TFT display as shown below:

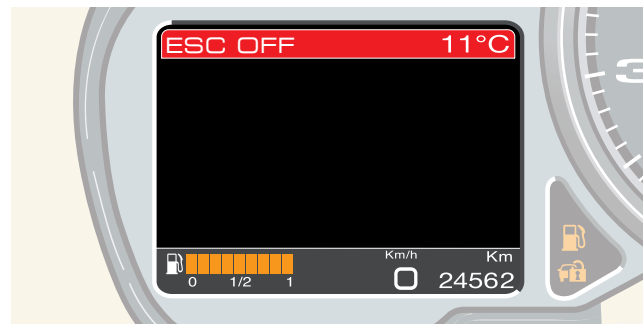



Park Lock

The Park Lock is a locking device built into the gearbox.

This device is used to prevent the vehicle from moving when the multi-disc clutches are open, i.e., with the engine off and/or without the hydraulic pressure required for gearbox operating.

The device operates automatically every time the key is turned to off: if a gear is engaged when the key is turned to off, the Park Lock is immediately activated. If the gearbox is in “N” (neutral), the Park Lock starts operating after a minimum preset time (needed for the Carwash procedure, see next paragraph). To inform the driver that the Park Lock has been engaged, the letter “P” is displayed on the gearbox display.

The Park Lock is deactivated when the engine is running, the first gear or “R” is requested (with the brake pedal pressed) and the engine compartment lid has been closed correctly.

If there is a system failure, refer to the “Emergency unlocking of Park Lock” section on page 246.

Carwash procedure

The Park lock device can be electrically disabled on a temporary basis when the engine is switched off by performing the Carwash procedure.

This procedure is necessary when the vehicle has to be moved with the engine off and when washing the vehicle.

Warning



When the Park Lock device is electronically deactivated (Carwash procedure), the vehicle may move. The vehicle is only kept stationary by the parking brake which must be applied.

3

To perform the Carwash procedure, do the following:

- with the engine running, select the first gear;
- select neutral “N”;
- switch off the engine;
- turn the key to position II (key-on) within 3 seconds of switching off.

The message “Carwash mode activation” will appear on the TFT display.



Launch Control

The “Launch Control” mode is a performance start function. Activating this function provides the vehicle the best possible acceleration.

The device transfers the necessary torque to the ground and avoids skidding of the wheels during acceleration.

To start the vehicle in “Launch Control” mode, do the following:

- the vehicle must be stationary;
- the gearbox must be in manual mode;
- select first gear;
- press the **LAUNCH** button **L** on the central console: an acoustic signal informs the driver that the device has been switched on and the word “launch” appears on the gearbox display;
- press the accelerator pedal and release the brake pedal.



Important note



The Launch control function is not available in presence of:

- a sloping road surface, even slight;
- high clutch temperatures.

Warning



Only use the “Launch Control” function in appropriate traffic conditions and in optimum safety and road surface conditions.



Suspension damping control (optional)

On request, the vehicle can be fitted with latest generation MagneRide™ magnetorheological suspension (optional), a system developed by Delphi and perfected by FERRARI for continuous automatic damping control.

By processing data received from the vehicle dynamics sensors and sensors that detect bodyshell movements, the ECU interprets the driving conditions and the road surface and immediately adjusts suspension response by varying the control current of each shock absorber. These sensors allow the ECU to calculate the vehicle speed, vertical and lateral acceleration, steering angle and instantaneous pressure in the braking system, and hence to control suspension damping.

This system not only ensures an optimal compromise between racing-style performance (handling) and comfort, but is capable of emphasising either aspect by using the different adjustments available controlled by the “Manettino” driving mode control switch. Three different setting levels are available on this vehicle.

Level 1 (COMFORT)

Slightly more flexible setting, optimised to better absorb road unevenness and provide a better grip on wet road surfaces (Manettino set to COMFORT).

Level 2 (SPORT)

Slightly more rigid adjustment optimised for sports-style driving and for high speed (with medium-high grip), without significantly affecting comfort (Manettino set to SPORT).

Level 3 (RACE)

Even more rigid setting optimised for use on the race track (Manettino set to ESC OFF).

Suspension damping delink button

The driver may decide to separate the suspension setting from the logic of the “Manettino” driving mode control switch using the special button **A** on the steering wheel.

By pressing button **A**, irrespective of the position of the Manettino, the suspension setting shifts to Level 1 (COMFORT).

Position of Manettino	Suspension setting	Button A pressed
COMFORT	COMFORT	remains COMFORT
SPORT	SPORT	shifts to COMFORT
ESC OFF	RACE	shifts to COMFORT

3

If button **A** has been pressed and subsequently the position of the Manettino is changed, the suspension setting follows the operating logic dictated by the Manettino.





Important note



Upon turning off and restarting the vehicle, the suspension setting depends on the position of the Manettino.

When the Manettino is set to SPORT or ESC OFF, shifting to the COMFORT suspension setting by pressing button **A** is indicated by displaying the special symbol and “Bumpy road” message on the left TFT display for 5 seconds.

After 5 seconds, next to the Manettino status in the top of the display, the suspension symbol continues to be displayed as shown in the photo below (example shows Manettino in “SPORT” mode).

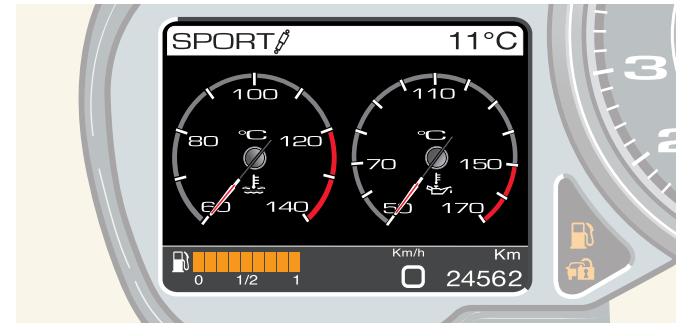



EPB - Electric parking brake

On this vehicle the parking brake is actuated by an electric motor. The parking brake can be applied and released by pulling a special lever **A** on the dashboard to the left of the steering wheel. With the ignition key turned to **II**, the relative indicator on the instrument panel (see page 152) lights up to indicate when the parking brake is engaged.

To release the parking brake, pull lever **A** and keep the brake pedal pressed. If the ignition key is in position **II**, the warning light will go out when the parking brake has been fully released.

The electric parking brake can be used as an emergency brake when the vehicle is in motion. If this is the case, the system acts on all four wheels until button **A** is released by communicating with the ESP system which prevents locking.

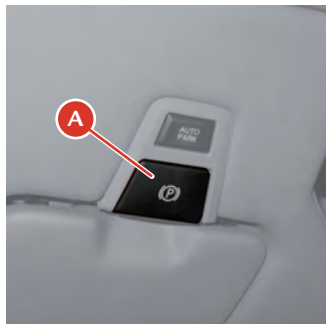

Warning



Always apply the parking brake when the vehicle is parked. The vehicle should be blocked. If this is not the case, please contact the **FERRARI SERVICE NETWORK**.

Drive Away function

The electric parking brake (EPB) has a “Drive Away” function: when a gear is engaged and the driver presses the accelerator pedal with the engine running and seat belt fastened, the system recognises the driver's intention to drive off and automatically deactivates the parking brake.

EPB deactivation warning

If you try to deactivate the electric parking brake by moving lever **A** without depressing the brake pedal, the message “Depress brake pedal and deactivate EPB” is immediately displayed on the TFT display accompanied by an acoustic signal.

3



Autopark Function

The EPB Autopark function automatically activates the electric parking brake when the engine is switched off. At each Key-on, the Autopark function is always active by default: this means that the driver does not need to apply the parking brake when the engine is switched off.

However, the function can be temporarily deactivated before switching off the engine by pressing the **AUTO PARK B** button: the message “PARK OFF” is displayed on the left TFT display for 5 seconds. If this is the case, the parking brake should be manually applied by pulling lever **A** once the engine has been switched off. To re-enable automatic EPB engagement at the next key-off, press button **B** again; the message “PARK ON” is displayed on the left TFT display for 5 seconds.

“Automatic Vehicle Holding” AVH function

The electric parking brake provides optimised release when the vehicle starts up due to its Automatic Vehicle Holding function: once the engine has started, the system keeps the vehicle braked through intervention of the braking system rather than through the parking brake shoes.

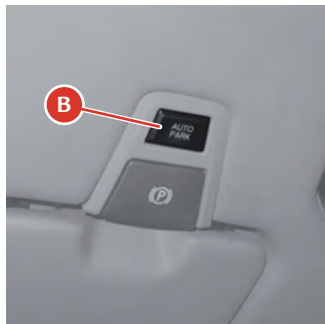



Stop&Start system (optional)

Vehicles with optional HELE (High Emotion Low Emissions) technology are equipped with a Stop&Start system which automatically stops the engine when the vehicle is stationary and restarts it automatically when the driver wants to set off again.

The aim of the Stop&Start function is to increase vehicle efficiency by reducing CO₂ emissions especially when driving around town.

Automatic stopping and restarting of the engine is controlled by sensors and control strategies which, while reducing the impact on vehicle flexibility and comfort to a minimum, guarantee full operating of the safety systems and all the on-board systems even when the engine is switched off and minimise the impact on on-board climate comfort.

Warning



Never leave the vehicle without turning the ignition key to position **0**.

Always remember to remove the key from the ignition when you get out of the vehicle!

Never leave children unattended in the vehicle.

Warning



Make sure that the engine is switched off with the ignition key in position **0** before refuelling.

Warning



Always make sure that the Stop&Start system has been deactivated before carrying out any repair and/or maintenance work as indicated on the special labels in the engine compartment and underneath the vehicle.

Failure to comply with the above may pose a risk of serious injury to people working on the vehicle.

Warning



The driver is personally responsible for leaving the key in the ignition in position **II** when getting out of the vehicle: the driver must always turn the ignition key to position **0** before getting out of the vehicle.

Warning



Leaving the vehicle with the ignition key in position **II** puts those who are in the vicinity of the vehicle at serious risk if the engine starts unexpectedly.

Warning



Always turn the ignition key to position **0** before changing the tyres.

3



How the system works

If activated, the Stop&Start system decides when to switch off the engine and when to restart it according to the driving conditions, the climate comfort on board and the operating status of the vehicle. The system logic does not require drivers to make any change in the way they drive the vehicle.

Manual activation and deactivation button

The driver can activate/deactivate the Stop&Start system at any time by pressing button **A** on the roof panel. If the system is activated, pressing button **A** will deactivate it: the message “Stop&Start OFF” appears for 5 seconds on the TFT display accompanied by a special symbol.

Once the system has been deactivated, pressing button **A** again reactivates the system: the message “Stop&Start ON” appears for 5 seconds on the TFT display accompanied by a special symbol.

If the Stop&Start system is activated, the LED on button **A** comes on whereas if the system is deactivated, the LED goes off.

Deactivation of the system by pressing button **A** while in a stopped vehicle condition (when the engine has been automatically switched off by the Stop&Start function) automatically restarts the engine.

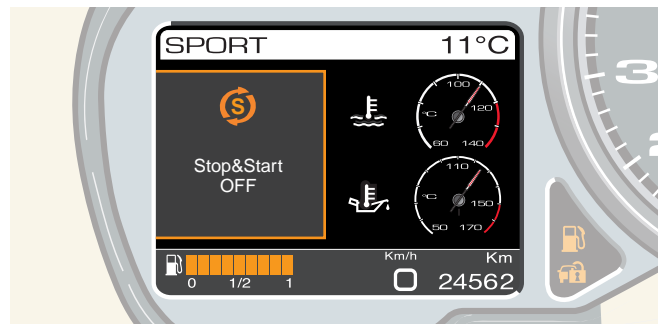



Important note



Each time the ignition key is turned to position **II** (Key-on), the Stop&Start system remains in the same state it was in when the switch was turned to position **0** (Key-off). If the function was activated at Key-off, it remains activated at the next Key-on and the LED on button **A** will flash for a few seconds.

Automatic engine stop mode

The engine stops automatically when the vehicle is stationary and the brake pedal is pressed, and restarts when the brake pedal is released.

The TFT display informs the driver that the Stop&Start system has been activated by displaying the message “Stop&Start active” accompanied by a special symbol. The message is displayed as long as the vehicle remains in a stop state. To interrupt the display cycle and reduce the message to an icon, press the **MODE** button with “ESCAPE” function.

3

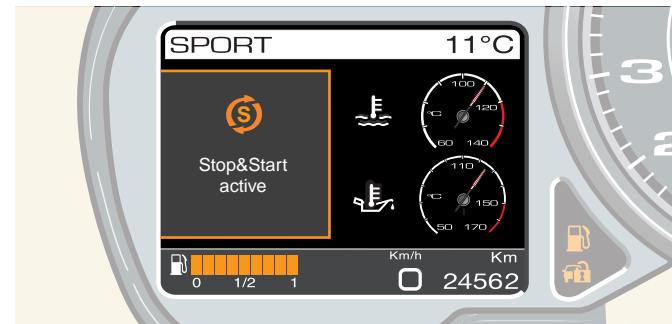
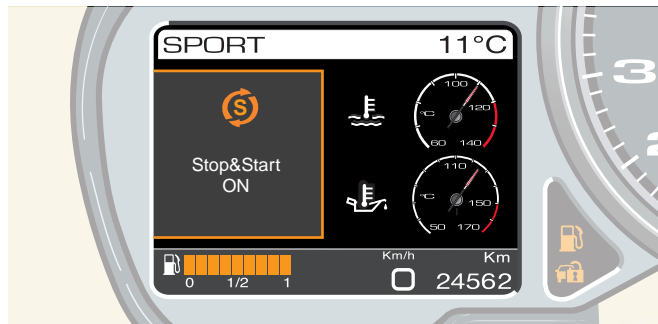



Conditions required to activate automatic engine stop

To activate the automatic engine stop while driving:

- **the Stop&Start system must be activated by pressing the button on the roof panel (LED on);**
- **the driver's seat belt must be fastened.**

For safety reasons and to guarantee driving comfort and correct operating of the entire vehicle, automatic engine switching-off is deactivated when:

- the accelerator pedal is depressed;
- a potentially dangerous situation is identified (steep road, vehicle stationary with wheels turned, i.e. when turning at a crossroads or on a roundabout);
- the system recognises vehicle motion in slow traffic or a parking manoeuvre (checking reverse gear engagement, time elapsed since last stop, driving speed);
- maximum air conditioning and heating system performance is requested ("low", "max defrost" or "rear screen demisting");
- external temperatures are very low or very high;
- the gearbox is in the "N" position;
- the DCT gearbox Park Lock has been manually released;
- a failure interferes with proper system operating.

The system also constantly monitors some of the vehicle operating parameters (battery charge level, engine coolant temperature, catalytic converter temperature, clutch oil temperature, vacuum level in brake servo, climate comfort in passenger compartment) so that engine switching off can be deactivated in certain conditions to guarantee safety and vehicle operating and minimise the impact on on-board climate comfort.

Important note



After the first cold start, the Stop&Start system may take a few minutes before it is ready. This time period allows some of the engine parameters (catalytic converter temperature, for example) to reach the values required to reduce emissions.

Important note



If the engine continues to run when the vehicle is stationary and the brake pedal is pressed, even if the Stop&Start system appears to be activated, it means that the system has disabled automatic switching off of the engine. When this happens, no specific signal is displayed on the instrument panel: this is to be considered normal.



Information on automatic restarting of engine

With the Stop&Start system activated in a stopped vehicle condition, the driver can restart the engine by:

- releasing the brake pedal;
- **UP**-shifting;
- engaging reverse gear;
- pressing the accelerator pedal.

Warning



If the engine is switched off accidentally and not by the Stop&Start system, it must be restarted manually by the driver by pressing the **ENGINE START** button and reengaging the gear using the shift paddles located behind the steering wheel. This condition is indicated on the TFT display by the message “Press **ENGINE START** button to restart”, accompanied by an acoustic signal.

For safety reasons and to guarantee comfort when the vehicle is stationary and correct operating of the entire vehicle, the Stop&Start system also automatically restarts the engine when:

- the **ENGINE START** button on the steering wheel has been pressed;
- the function has been deactivated by pressing the button located on the roof panel;
- the driver's seat belt has been unfastened;
- the driver-side door has been opened;
- the hard top is being opened or closed;
- rear screen demisting has been requested or the air conditioning and heating system set to “low” or “max defrost”.

The system also constantly monitors some of the vehicle operating parameters (battery charge level, engine coolant temperature, catalytic converter temperature, clutch oil temperature, vacuum level in brake servo, climate comfort in passenger compartment, vehicle speed) so that the engine can be automatically started in certain conditions to guarantee safety and vehicle operating and minimise the impact on on-board climate comfort.



Permanent deactivation of automatic restarting and manual start procedures

After automatically switching off the engine using the Stop&Start system, automatic restarting requested by the driver may not always be possible: this means that the vehicle systems have permanently deactivated automatic restarting.

If this occurs, the vehicle must be restarted manually: This condition is indicated on the TFT display by the message “Press ENGINE START button to restart” accompanied by an acoustic signal.

Warning



If automatic restarting is permanently disabled, the vehicle behaves in the same way as a vehicle with no Stop&Start system: to restart, the driver must perform a manual start by pressing the **ENGINE START** button and using the shift paddles located behind the steering wheel.

Permanent deactivation of automatic restarting occurs when:

- the engine compartment lid is open;
- automatic engine restarting has not been successful;
- a failure has been detected that may interfere with operating of the Stop&Start system.

At times, depending on the seriousness of the failure, the **ENGINE START** button may have to be held down for a few seconds to restart the engine: this condition is indicated on the TFT display by the message “Press and hold ENGINE START button to start” accompanied by an acoustic signal.

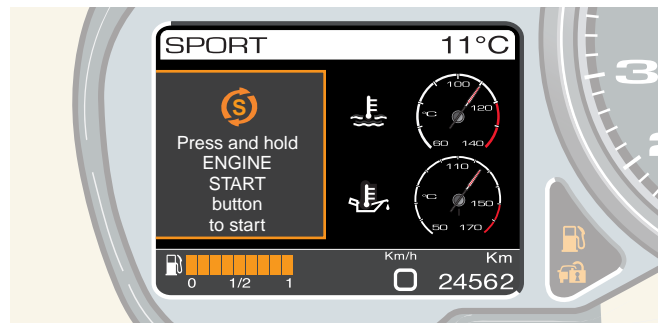
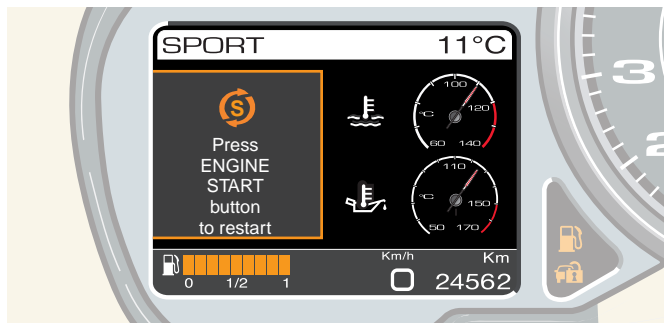



System failure

If malfunctioning, the Stop&Start system is disabled. The driver is informed of the failure by a special symbol that appears on the TFT display for 20 seconds accompanied by an acoustic signal and the following message which corresponds to two different alarm levels:

- “Stop&Start failure”.
- “Stop&Start failure. Go to dealer”.

Important note



Contact the **FERRARI SERVICE NETWORK** immediately.

When the display cycle ends (20 seconds), or the **MODE** button with “ESCAPE” function is pressed, the message disappears and the symbol is reduced to an icon.

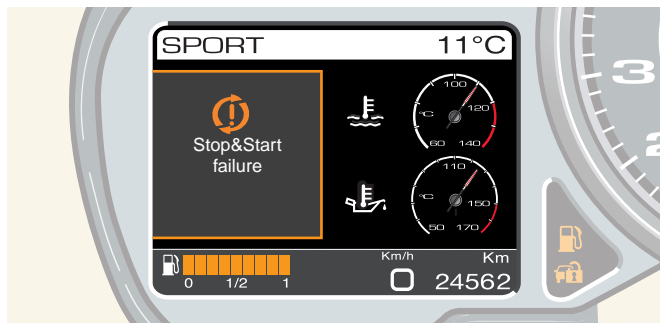

Precautions to be taken during maintenance work

Always turn the ignition key to position **0** before carrying out any repair and/or maintenance work on the vehicle. If work has to be carried out on the vehicle with the ignition key in position **II**, check that the Stop&Start has been deactivated by performing the following procedure before doing any repair and/or maintenance work:

if the ignition key is in position **II**, turn it to **0** before turning back to **II**, then press the Stop&Start system activation/deactivation button on the roof panel (see page 186). If the message “Stop&Start ON” appears on the TFT display when the button is pressed, press the button again. Check that the message “Stop&Start OFF” appears on the TFT display for 5 seconds. The button LED must be off.

Warning



NEVER work on the vehicle if the message “Stop&Start active” appears on the TFT display.

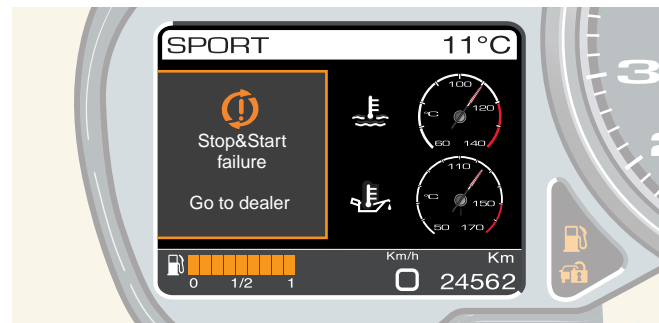

3



Dome light controls (HELE system only)

On vehicles with the optional HELE system, the central dome light **B** can be switched on or off by holding button **C** or **D** down (for more than 0.8 seconds).

The driver-side spotlight and the passenger-side spotlight can be switched on and off by pressing and quickly releasing buttons **C** and **D** respectively.

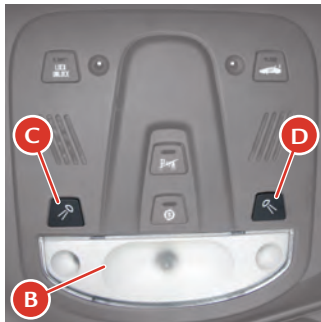



Seat adjustment

Warning



As with all adjustment, seat adjustment must be performed when the vehicle is stationary.

Warning



Never place your hands under the seat or near its moving parts when adjusting. If you do so, movement of the seat may cause injury to hands or fingers.

Correct adjustment is very important for enhanced driving comfort and maximum efficiency of the passive safety systems.



The seat position can be electrically adjusted using the special controls.

Three adjustments are possible using control **D**:

- backward/forward adjustment: push the control forwards or backwards;
- height adjustment: push the control up or down;
- seat inclination (tilting): push the front or rear end of the control up or down to adjust seat inclination.

Warning



Forward/backward adjustment must take into account the fact that airbag devices are placed in front of the driver and the passenger.

Correct adjustment ensures there is adequate space between the airbag and the driver/passenger (see page 58).

3



Seat back rake adjustment

Use control **E** to adjust the seat back rake. Push the control forward or backward to adjust the seat back rake.



Tilting the backrest

Pull lever **L** to tilt the backrest forward. When the backrest goes back into position, it will automatically block once it has reached the correct position.

Warning



Do not use the electric seat adjustment controls when the backrest is tilted.

Lumbar support adjustment (Full Electric option)

Use control **F** to adjust the seat backrest lumbar support. Push the horizontal arrows on the control left or right to increase or decrease lower lumbar support. Push the vertical arrows on the control up or down to increase or decrease upper lumbar support.





Backrest and cushion side width adjustment (Full Electric option)

Use control **G** to pneumatically adjust the width of the backrest and seat cushion sides. Push the horizontal arrows on the control left or right to increase or decrease the width of the seat cushion sides. Push the vertical arrows on the control up or down to increase or decrease the width of the backrest sides.



Seat position memory

When a door is open and the key is in position 0, the seat can be moved for a limited period (approx. 15 sec.). Each time a door is opened or both doors are closed and the key is set to OFF, the seat can be moved again for a limited period.

The seat position can only be memorised when the key is in position II, by pressing one of the three buttons 1, 2 or 3 (**H**) each one corresponding to a memorisable position. Pressing one of these buttons for longer than 3 seconds memorises the position of the driver seat, rear-view mirrors and steering wheel (confirmed by emission of a double tone).

To recall the memorised position, press one of the buttons **H** and release it within 3 seconds. Operation begins as soon as the button is released.

Recalling the memorised position is not allowed when the vehicle is in motion. If the vehicle starts to move while the memory recall is being operated, the seat and column do not stop moving and reach the memorised position.

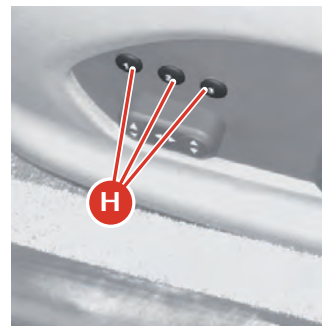

3



If the memorised backward/forward position of the passenger seat is less than approximately 50 mm from the rear end of travel, when this seat position is recalled from a differently adjusted position, the seat stops once it is approximately 50 mm from the rear end of travel. The position can be adjusted by using the backward/forward adjustment control.

With reverse gear engaged, the position of the passenger external rear-view mirror can be adjusted to a position other than the driving position, to help parking manoeuvres. This position can be memorised along with all the other memorisable positions.

If the personalised reverse gear position is never set, when the reverse gear is engaged, the passenger external rear-view mirror will be positioned slightly downwards and inwards (with respect to the driving position).

Seat heating system (Full Electric option)

Turn control **N** to activate the seat heating function.

When this function is active for one or more seats, the relative warning light comes on on the instrument panel. Using control **N**, the driver can adjust the heating, choosing from 3 levels identified on the control with the numbers 1, 2 and 3. In position 0, seat heating is not activated.

Driver seat Easy Entry/Exit (Full Electric option)

To help the driver to get in and out of the vehicle, the driver seat Easy Entry/Exit function is activated (only operative when the door is open and the key is in position **0**) which moves the steering wheel column upwards. When the door is closed and the key is in position **II**, the steering wheel column returns to its original position.

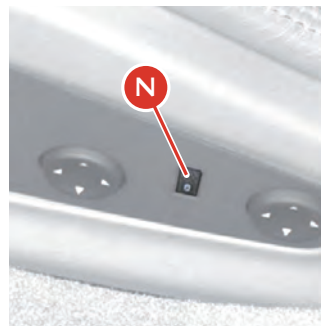



Adjusting the steering wheel

Mechanical adjustment

- 1) Release lever **X** by pushing it forwards.
- 2) Adjust the position of the steering wheel.
- 3) Block the steering wheel by pulling lever **X** until it locks into position.

Electrical adjustment

It can only be adjusted if the ignition key is in position **II**.

Move control **A** (to the left of the steering column) in the four directions to adjust the steering wheel.

The steering wheel position is memorised, together with the position of the external rear-view mirrors, when the driver's seat position is stored.

Warning



Do not adjust the steering wheel while driving.

To help the driver when entering or exiting the vehicle, the steering wheel is lifted automatically.

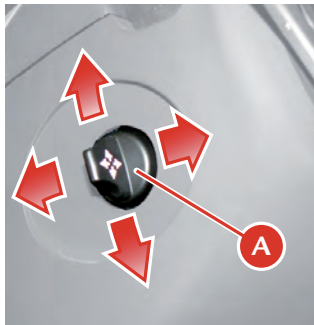

Rear-view mirrors

Internal rear-view mirror

Hold the internal rear-view mirror and move it to the required position.

On request, the internal rear-view mirror can be fitted with an electrochromic mirror that automatically darkens to reduce the dazzling effect of the reflected light on the driver. The speed with which the mirror darkens depends on the intensity of the light.

By pressing button **B** you can activate/deactivate the electrochromic mode. When the electrochromic mode is activated, the green LED **D** comes on.

3





External rear-view mirrors

These mirrors can be electrically adjusted using the control **C** (with the ignition key in position **II**) and are equipped with defogging elements.

- 1) Mirror selection: turn control **C** to the left or right lock position to select the mirror that requires adjusting.
- 2) Mirror positioning: move control **C** in the four directions (up – down – right – left) to adjust the selected mirror.
- 3) Mirror closure (optional): turn control **C** to the lower central lock position to close the rear-view mirrors.

Once adjusted, move the control **C** into the upper central position where it will be locked in order to avoid changing the external mirror setting inadvertently.

The mirrors will yield in both directions in the event of a collision: if necessary, the mirrors can be pushed both backwards and forwards.

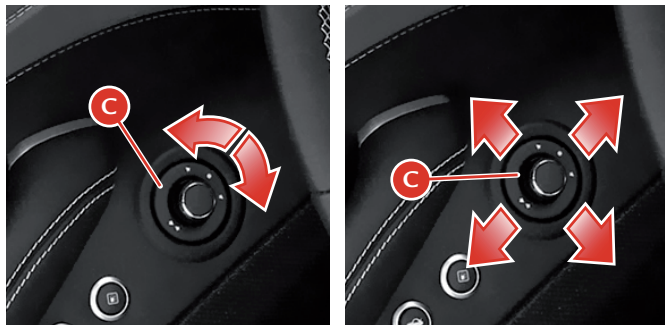

In the models equipped with memory seats, every time the seat position is memorised, the external rear-view mirror position is also stored automatically, both for the normal travelling direction and for reverse manoeuvring.

To memorise a new position of the external rear-view mirrors, turn the ignition key to position **II** and adjust the position of the mirrors; then engage reverse and reposition the external mirrors to ensure the best possible visibility to perform the manoeuvre, then disengage reverse gear.

Finally, press one of the buttons 1, 2 or 3 on the seat (see page 195), each one corresponding to a memorisable position, until a double tone confirms that the procedure is complete.

The new position of the external rear-view mirrors will be automatically memorised together with the seat position.

In addition, the mirror positions can be adjusted for both the normal travelling direction and for reverse manoeuvring.

Warning



The rear-view mirrors must always be positioned correctly while driving.

Do not adjust the rear-view mirrors when the vehicle is moving.

On request, the external rear-view mirrors can be fitted with an electrochromic mirror.



Air conditioning and heating system

Operating modes

Automatic

This mode automatically adjusts the air distribution, temperature and ventilation levels according to the temperature set by the user.

Partially Automatic

This mode allows the user to adjust certain parameters manually, while others remain automatic.

Manual

This mode allows the user to set the values to suit the passengers' needs.

Controls

- 1 Left-hand temperature setting and AUTO button
- 2 A.C. compressor activation/deactivation
- 3 Single-zone mode activation/deactivation
- 4 Air distribution fan speed
- 5 Rear window demist activation/deactivation
- 6 Windscreen demist activation/deactivation
- 7 Right-hand temperature setting and AUTO button
- 8 Right-hand air distribution mode setting
- 9 Air recirculation
- 10 Left-hand air distribution mode setting.

3

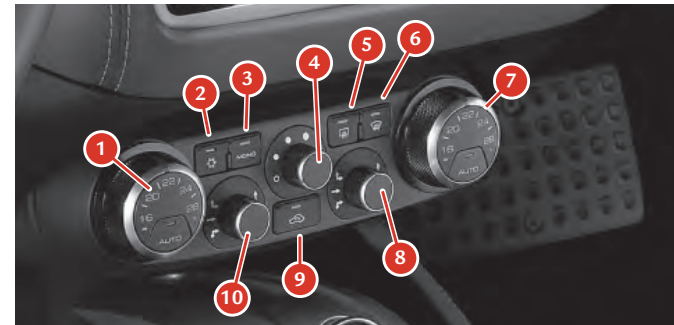



Left-hand temperature setting and AUTO button (1)

This is used to select the required air temperature in the left-hand side of the passenger compartment; the AUTO button is used to activate automatic operation (LED on).

A.C. compressor activation/deactivation (2)

This is used to activate (LED on) or deactivate (LED off) the A.C. compressor.

Single-zone mode activation/deactivation (3)

This is used to activate (LED on) or deactivate (LED off) the single-zone operating mode.

Air distribution fan speed (4)

The four setting positions allow the occupants to select the air flow rate.

Rear window demist activation/deactivation (5)

Press this button (LED on) to activate rear window defogging/demisting.

Windscreen demist activation/deactivation (6)

Press this button (LED on) to activate windscreen defogging/demisting.





Right-hand temperature setting and AUTO button (7)

This is used to select the required air temperature in the right-hand side of the passenger compartment; the AUTO button is used to activate automatic operation (LED on).

Right-hand air distribution mode setting (8)

This is used to select one of the six air flow distribution modes in the right-hand side of the passenger compartment.

Air recirculation (9)

If released (LED off); the air flow comes from the outside.

When outside temperatures exceed 32 °C (90 °F), the air recirculation feature remains on with a 60-second pause every twenty minutes to refresh the air.

If you activate the windscreen washer function, the air recirculation feature activates for 20 seconds, to prevent any smell of detergent products from entering the passenger compartment.

If pressed (LED on), the air flow comes from inside the passenger compartment.

The recirculation increases air heating or cooling.



Left-hand air distribution mode setting (10)

This is used to select one of the six air flow distribution modes in the left-hand side of the passenger compartment.

Once the internal temperature has stabilised at the desired level, you are advised not to change the position of the temperature selection switch unless the external temperature changes drastically.

Important note



The air coming out of the vents does not correspond to the temperature requested by the user, but is the temperature required to maintain the desired temperature inside the passenger compartment.

3





Adjusting the air vents

The adjustable air vents are positioned on the sides and in the central section of the dashboard, air flow direction **A** and air flow rate **B**. Turned counterclockwise: open. Turned clockwise: closed.

Important note



It is advisable to keep the air flow rate control **B** set to open and to direct the air flow control **A** to a neutral position.

Maintenance

The pollen filter must be replaced every year, as indicated in the “Maintenance Schedule”.

Sun radiation sensor

This sensor is positioned on the dashboard and optimises ventilation and temperature control inside the passenger compartment depending on the incidence angle of the sun rays.

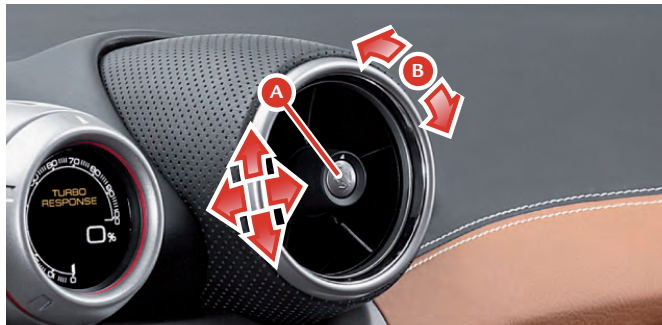

Passenger compartment accessories

Glove compartment

This is located on the passenger side of the dashboard. To open it, pull lever **C** and the glove compartment will move down slowly by way of a damped opening mechanism.

The glove compartment is illuminated by a light which turns on automatically when the door is opened.

Warning



Keep the glove compartment closed while driving.

To close the glove compartment, push the top part until you hear the click of the lock.





Oddment storage compartments

They are located on the lower part of the doors and on the centre console.

Sun visors

The sun visors can be moved by pulling them down towards the windscreen.

There is a mirror on the back of the passenger-side visor.

3





12V power socket

The vehicle has a power socket **D**, positioned in the glove compartment under the armrest.

The socket can be used to power small electrical appliances including: mobile phones, lights, vacuum cleaner and any other accessory with absorption not exceeding 140 Watts and a voltage of no more than 12 Volts.

Warning



Prolonged use of this device may discharge the battery. Do not try to insert plugs into the power socket that are not the right size and shape.

Warning



Use the power socket to connect the tyre repair and inflation kit in an emergency **ONLY** for the amount of time strictly necessary.



Flaps communicating with luggage compartment

To open the passenger compartment flaps communicating with the luggage compartment **F** actuate the release levers **G** on the sides of the luggage compartment and then open them by lowering them towards the front of the vehicle.





Placing suitcases in the luggage compartment

The luggage compartment secures any suitcases in the luggage compartment and prevents the hard top from jamming when operated. Make sure you have closed the partition correctly so that it is blocked correctly both on the left and the right.

Warning



Do not place any objects above the partition: this will help to avoid the risk of causing serious damage to the opening and closing mechanisms.

Warning



Do not place any objects in the folded roof compartment: this will help to avoid the risk of causing serious damage to the opening and closing mechanisms.



Warning



Do not place any objects on or next to the partition between the luggage compartment and the folded roof compartment when closed. Do not place any luggage so that its height exceeds that of the closed partition.

Important note



If possible, use the eyebolts to fasten the luggage with clamps or a rope.

3

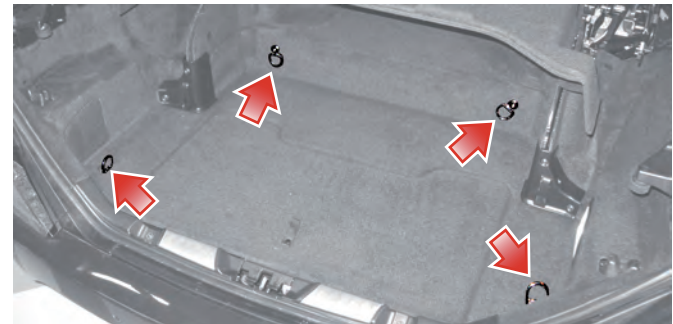



Wind deflector

The wind deflector can be used while driving with the retractable hard top open. It reduces wind buffeting in the passenger compartment and provides more comfort during trips at higher speeds too.

The deflector is stored in a special bag inside the luggage compartment.

Fitting

The deflector is divided into two parts: **A** and **B**.

- Take part **A** and open it as shown in the figure.

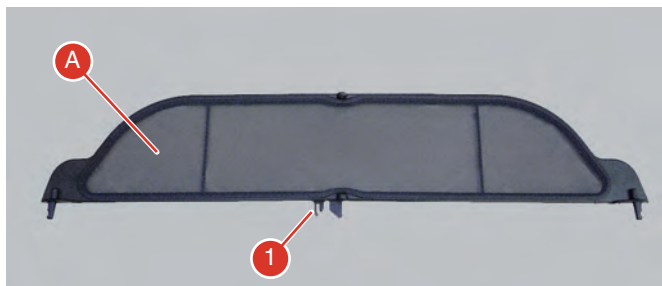

- Take part **B** and open it as shown in the figure.

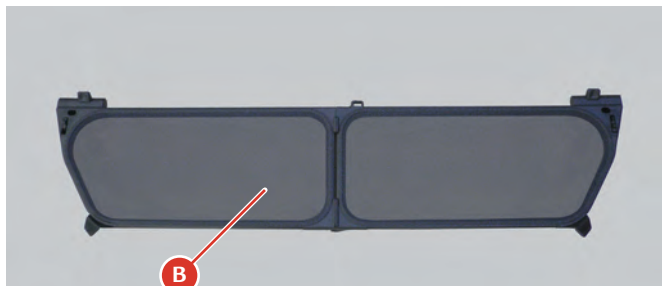

- Fit part **A** onto part **B** as shown in the figure.

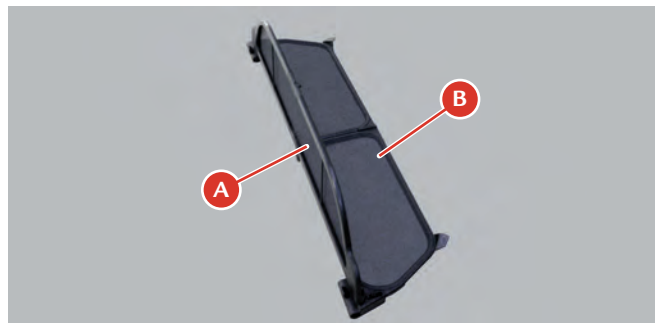

Important note



Make sure that the hook **1** has been correctly inserted.





Important note



Lock the fastenings 2 on the right and left of the deflector B.

- Push the pin 3 until it snaps into place.

3

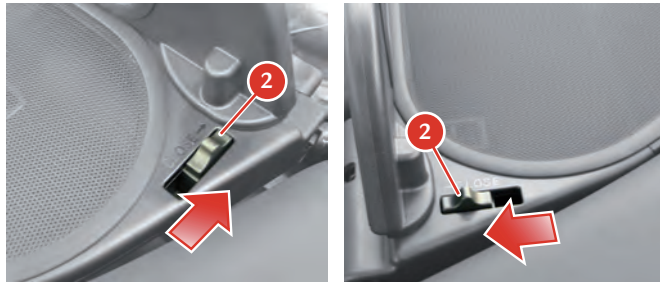



- Place the deflector with its supports **4** fitted in the special slots on the left and right of the vehicle and pin **3** in the special hole on the right of the vehicle.

Important note



Pay attention to the vehicle trim.

- Push the other pin **3** into the special hole on the left of the vehicle, until it snaps in place.

Warning



When the deflector is fitted, if you must move the seat back up to the end of travel, do not tilt the front seats too far back to avoid damaging the deflector.

Warning



Check that the deflector has been secured correctly!

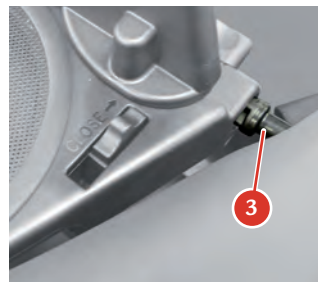



1. General

2. Safety

3. About your Vehicle

4. Advice for Emergency Situations

5. Care of the vehicle

6. Glossary

7. Table of Contents







Warning



Repair work using the toolkit requires:

- suitable protective equipment (e.g. gloves);
- adequate precautions to be taken (e.g. during tyre replacement never lie under a vehicle raised by a jack);
- minimum specific expertise when working in contact with electrical parts/components (e.g. battery).

Toolkit

Tool bag

Stored in the luggage compartment, it contains the necessary tools for emergency repair jobs:

- pair of cotton gloves;
- set of fuses;
- pliers for removing fuses;
- tow hook;
- funnel for emergency refuelling;
- screwdriver for slotted and crosshead screws;
- EPB emergency release tool;
- Park Lock emergency release tool;
- emergency tyre repair and inflation kit.





Emergency tyre repair and inflation kit

In the event of a puncture or low pressure of a tyre, the kit can be used to repair and/or inflate the tyre sufficiently to continue the journey safely.

Important note



To use the tyre repair and inflation kit correctly, refer to the instruction booklet provided with the kit.

Warning



Give the instruction booklet supplied with the kit to the personnel that will have to deal with the tyre treated with the repair kit.

Warning



In the event of a puncture caused by foreign objects, tyres can be repaired with cuts of up to **4 mm** in diameter on the tyre tread and shoulder.

Warning



Punctures cannot be repaired on the sides of the tyre. Do not use the tyre repair kit if the tyre has been damaged after driving with a flat tyre.

Warning



Damage to the wheel rim that causes air leaks cannot be repaired. Do not remove foreign objects (screws or nails) that have penetrated the tyre.

Warning



After using the repair kit, the vehicle must be considered in an emergency situation: drive with the greatest care (maximum permissible speed 80 km/h).

Warning



Apply the sticker where it can easily be seen by the driver to indicate that the tyre has been treated with the tyre repair kit. Drive carefully especially on bends. Avoid sudden accelerations or braking.



Warning



The kit is to be used to temporarily repair only one tyre punctured by small objects: the kit may not be useful in the case of large punctures or tearing.

Important note



After driving for approximately 10 minutes, stop and recheck the tyre pressure.
Remember to use the handbrake.

Warning



If the pressure has decreased below **1.8 bar**, do not continue driving: the kit cannot guarantee the correct hold because the tyre is too damaged. Contact the FERRARI SERVICE NETWORK.
If the tyre pressure is at least **1.8 bar**, restore the correct pressure and continue driving.
Drive very carefully to the nearest FERRARI SERVICE NETWORK.

Warning



The repaired tyre must be replaced as soon as possible and the workshop personnel must be informed that the tyre was treated with tyre repair fluid.

Warning



Keep the kit in its box and out of children's reach.
Do not inhale or swallow the fluid contained in the cartridge and avoid contact with the skin and eyes.



Warning



The spray contains ethylene glycol.

It contains latex: it may cause an allergic reaction. Harmful if swallowed. Irritating to eyes. May cause sensitisation by inhalation and skin contact. Avoid contact with eyes, skin and clothing. In case of contact, rinse immediately with plenty of water. If swallowed, do not induce vomiting, rinse mouth, drink plenty of water and seek immediate medical advice. Keep out of reach of children. The product should not be used by asthma sufferers. Do not inhale vapours during use. In the event of an allergic reaction, seek immediate medical advice. Store the spray can in its special case away from sources of heat.

The liquid sealant has an expiry date.

Environment



Replace the spray can containing the expired liquid sealant. Do not dispose of the spray can in normal domestic waste. Dispose of in accordance with national and local regulations.

Warning



The sealant in the kit cartridge can damage the sensor inside the wheel rim on vehicles fitted with a tyre pressure monitoring system.

If this occurs, the sensor must be replaced. Contact the FERRARI SERVICE NETWORK.

Warning



Wear the protective gloves provided with the tyre repair kit.

Useful accessories

In addition to the tools supplied with the vehicle, the hazard warning triangle and fluorescent safety jacket should always be kept on board in order to signal hazardous situations in compliance with regulations.



Replacing the headlight bulbs

Important note



The low/high beams are equipped with bi-xenon light bulbs.
To replace the headlight bulbs, contact the FERRARI SERVICE NETWORK.
To adjust the headlight beam, please contact the FERRARI SERVICE NETWORK.

Replacing the supplementary taillight bulbs

Important note



To replace the supplementary taillight bulbs, contact the FERRARI SERVICE NETWORK.

Replacing the taillight bulbs

Important note



To replace the taillight bulbs, contact the FERRARI SERVICE NETWORK.





Replacing number plate light bulbs

Important note



To replace the number plate light bulbs, contact the **FERRARI SERVICE NETWORK**.

Replacing other light bulbs

Roof dome light

- Use a screwdriver to gently pry out the edge of the transparent cover **C** of the dome light and remove it from the roof panel.
- Replace the bulb **D** or **E** or **F**.
- Refit the dome light and make sure that the wires are not trapped by inserting it first from the connector side and then pressing on the opposite side.

4

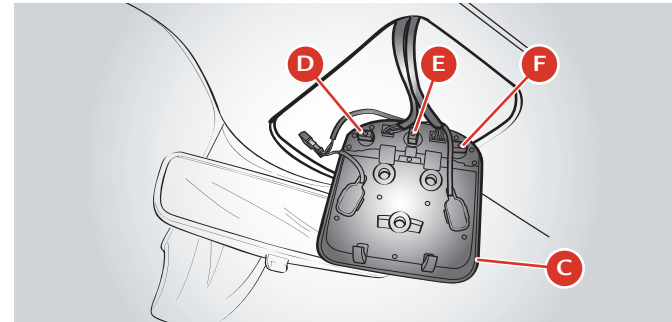



Glove compartment and luggage compartment light

- Use a screwdriver to gently pry out the edge of the transparent cover **G** and lift it.
- Completely remove the transparent cover from its housing.
- Take the bulb out of its clips.
- Replace the bulb.
- Refit the transparent cover and make sure that the wires are not trapped by inserting it first from the connector side and then pressing on the opposite side.

Replace the luggage compartment light bulb in the same way.



Underdoor light

- Use a screwdriver to gently pry under the edge of the transparent cover and lift it.
- Completely remove the transparent cover from its housing.
- Take the bulb **H** out of its clips.
- Replace the bulb.
- Refit the transparent cover and make sure that the wires are not trapped by inserting it first from the connector side and then pressing on the opposite side.

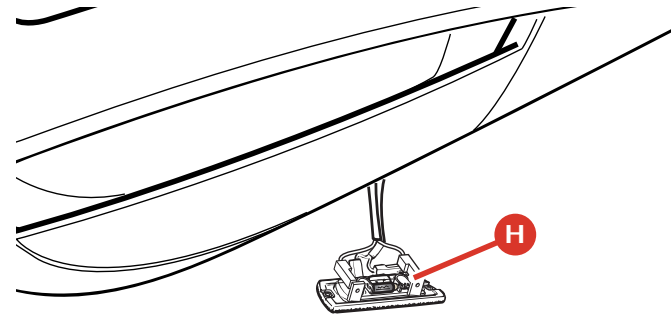



Light bulbs

	Type	Power
Low beams and high beams	gas-discharge (mercury-free XENON)	Das
Front running lights	LED	
Front turn indicators	LED	
Side turn indicators	incandescent	T4W
Upper rear taillight	LED	
Number plate lights	LED	
Supplementary stop lights	LED	
Fixed part of reverse lights	LED	
Running/stop lights on moving part of taillight	LED	
Fixed part of rear turn indicators	LED	
Rear fog lights	LED	
Dome light	incandescent	8W
Spotlight	incandescent	5W
Glove compartment light	LED	
Underdoor courtesy light	incandescent	W5W
Luggage compartment light	incandescent	10W



Replacing a fuse

When an electrical device is not working, check that the corresponding fuse is not blown.

A - Unblown fuse.

B - Blown fuse.

Important note



If the problem persists, contact the **FERRARI SERVICE NETWORK**.

Important note



When replacing a fuse, always use fuses of the same amperage (same colour).

The tool bag contains spare fuses.

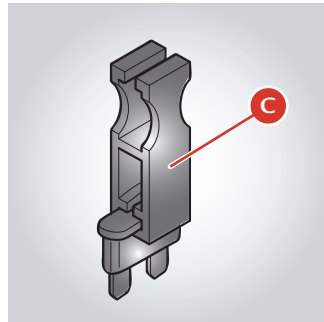
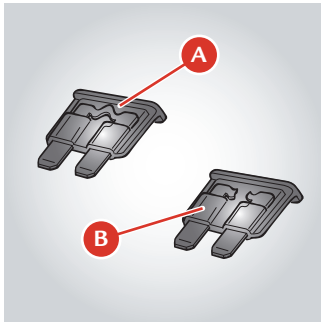

Use the pliers **C** in the fuse box in the passenger compartment behind the dashboard to the left of the steering wheel to remove the fuses.

Fuse colours

	Ampere
yellow ochre	5
brown	7.5
red	10
light blue	15
yellow	20
white	25
green	30

Maxi fuse colours

	Ampere
yellow	20
green	30
orange	46
red	50
blue	60



Location of the fuse and relay boxes

A - Fuses and relays in the engine compartment

B - Body Computer fuses and relays

C - Fuses and relays in passenger the compartment on passenger side

D - Fuses and relays in passenger the compartment on centre console

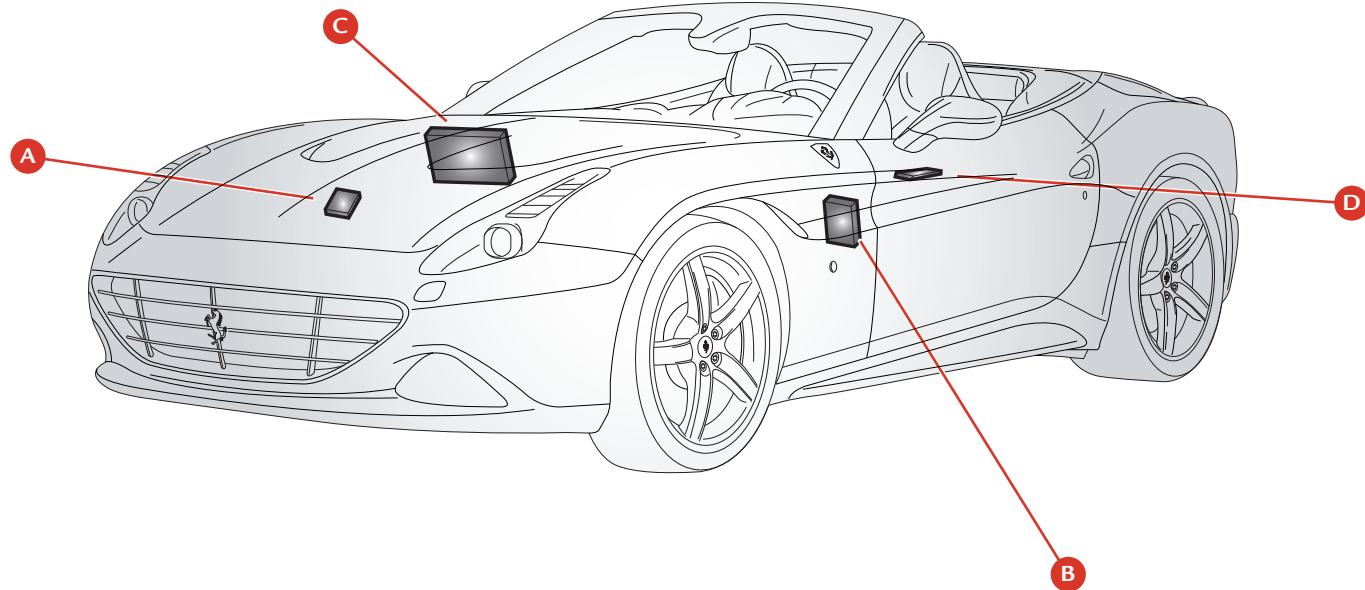



Fuses and relays in the engine compartment

To access these fuses:

- open the engine compartment lid;
- remove the box cover **A**.

Important note



Only open the boxes containing the fuses that need to be checked to avoid damaging other components.

Box **A** contains these fuses:

Ref.	Amp.	Use
CAL5	CAL5	Power supply (starter motor and alternator).
F-70	150	Power supply and engine relay
F-71	40	Hard top pump

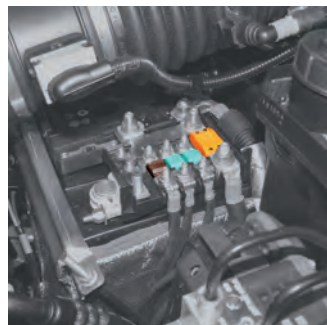

F-72	40	Parking brake power
F-73	70	Dashboard ECU power

Body Computer fuses and relays

To access these fuses, remove the flap **I** by unscrewing the two fastener screws.

Box **B** contains the following relays (**R**) and maxi fuses (**MF**):

Important note



Only open the boxes containing the fuses that need to be checked to avoid damaging other components.

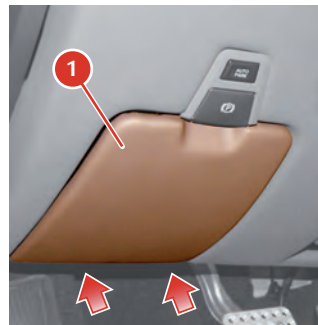



Box **B** contains the following relays (**R**) and maxi fuses (**MF**):

Ref.	Amp.	Use	*STOP&START
F-12	15	Right high beam	
F-13	15	Left high beam	
F-31	7.5	AC unit, body computer connector	
F-32	10	Dome lights, foot well and step lights, side markers, supplementary taillights	
F-35	7.5	Clutch pedal control, Cruise control, power steering, beams	
F-36	10	Satellite alarm system, parking sensors, fuel filler flap	
F-37	10	Stop light control	
F-38	15	Luggage compartment lock	
F-39	15	+ 30 radio, air conditioning, diagnosis, CAN BOX, alarm siren. *+30 air conditioning, diagnosis, CAN BOX, alarm siren	
F-40	30	Heated rear window	
F-42	7.5	Parking cameras	
F-43	30	Windscreen washer/wiper relay power supply	
F-44	20	Passenger seat heating	
F-46	20	Hard top	
F-47	30	Driver-side door	
F-48	30	Passenger-side door	
F-49	7.5	Passenger compartment lighting switches and controls	

F-50	7.5	Airbags
F-51	7.5	Electronically controlled gearbox, engine start button
F-52	15	Power socket, driver seat heating
F-53	10	Instrument panel
	*n.v.	*NOT USED
T01	20	Low beam relay
T11	30	Heated rear window relay
T12	30	Service relay 1
T13	joint	Service powering jumper 2



Passenger side fuses and relays

To access these fuses, remove the passenger footrest **2** by unscrewing the four fastener screws.

Box **C** contains the following relays (**R**) and fuses (**F**):

Ref.	Amp.	Use	*STOP&START
F-01	60 40*	+30 LH electric fan +30 LH electric fan (BRUSHLESS)*	
F-02	30 40*	+30 F-97, F-98 +30 Voltage stabilizer (front)*	
F-03	50	+30 Fuel pump ESD ECU (PWM)	
F-04	50	+30 ABS (pump)	
F-05	40	+30 Air conditioning and heating system	
F-06	50 40*	+30 RH electric fan +30 RH electric fan (BRUSHLESS)	
F-07	20	+30 Horn relay	

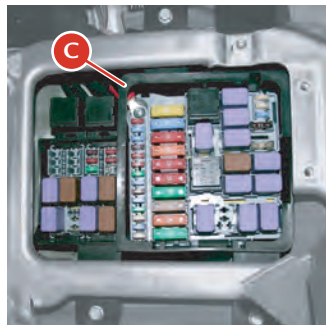
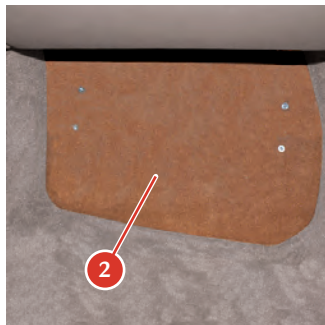

F-08	7.5	Air conditioning and heating system compressor
F-09	7.5	+30 Supplementary stop light relay
F-10	15	+30 Luggage compartment lock relay
F-11	25	Motronic ECU services
F-14	15	+30 High beam relay
F-15	n.v.	NOT USED
F-16	n.v.	NOT USED
F-17	25	Motronic, air flow meter power supply (F100)
F-18	n.v.	NOT USED
F-19	7.5	+30 RH/LH cylinder bank injection system power supply
F-20	n.v.	NOT USED
F-21	30	+30 Ignition switch
F-22	15	Ignition coil, starting relay power supply
F-23	30	+30 F-94, F-95, F-96 +30 Voltage stabilizer (front)*
F-24	n.v.	NOT USED
F-30	30	+30 Starting relay
F-81	40	+30 F-91, F92, F93
F-82	70	+30 Dashboard ECU and luggage compartment ECU power supply
F-83	50	+30 Air pump relay
F-84	n.v.	NOT USED
F-85	25	Headlight washer relay



F-87	n.v.	NOT USED
F-88	n.v.	NOT USED
F-89	10	+15 from ignition switch
F-90	7.5	Motronic/Stabilizer start-up
F-91	7.5	+30 for Tyre Pressure Node (NTP) and T38
F-92	10	+30 for T19, T38, T39
F-93	30	LH electric fan relay
F-99	15	Misc. electronic injection services
F-100	7.5	Ionising ECUs
T02	n.v.	NOT USED
T03	30	Luggage compartment lock actuator relay
T05	50	Horn relay
T06	30	Air conditioning and heating system compressor relay
T07	30	Motronic main relay
T08	n.v.	NOT USED
T09	n.v.	NOT USED
T10	10/20	INT/A relay (devices excluded at ignition)
T14	30	Stop light control relay
T17	30	RH electric fan relay
T19	50	+30 Air pump relay
T20	30	Headlight washer pump relay
T26	30	Windscreen wiper relay (first speed)
T27	30	Windscreen wiper relay (second speed)

T28	30	Windscreen washer pump relay
T29	30	Supplementary stop light relay (third stop light)
T30	50	Air pump relay
T37	10/20	Left supplementary taillight relay
T38	30	Left headlight LED module power supply relay
T39	30	Right headlight LED module power supply relay
T31	30	Headlight washer pump relay
T40	30	Relay for +15 buttons
TXX	50	Starting relay 2
TY Y	50	Starting relay 3



Fuses and relays on centre console

To access these fuses, remove the cosmetic shield in the pocket change tray on the centre console by unscrewing the socket head screw **E**.

Box **D** contains the following relays (**R**) and fuses (**F**):

Ref.	Amp.	Use
F-54	20	+30 HI-FI amplifier
F-55	n.v.	NOT USED
F-56	30	+30 Driving position (NAC)
F-57	7.5	Side Markers 1 (LH front and RH rear)
F-58	n.v.	NOT USED
F-59	7.5	Reverse lights
F-60	30	+30 Passenger position (NAP)
F-61	7.5	+30 Driving position (electronic NAC)
F-62	7.5	+30 Passenger position (electronic NAP)

F-63	15	+30 Electronically controlled gearbox main relay (NCR)
F-64	7.5	Fuel filler flap actuator
F-65	20	Door lock actuator
F-66	7.5	+30 Electronically controlled gearbox
F-67	7.5	Side Markers 2 (RH front and LH rear)
F-68	n.v.	NOT USED
F-69	n.v.	NOT USED
F-77	n.v.	NOT USED
F-78	15	+30 Battery charger
F-79	n.v.	NOT USED
F-80	n.v.	NOT USED
T21	50	Side Marker relay
T22	30	Reverse light relay
T23	30	Fuel filler flap relay
T24	10/20	Supplementary taillight switch relay
T25	30	Electronically controlled gearbox main relay

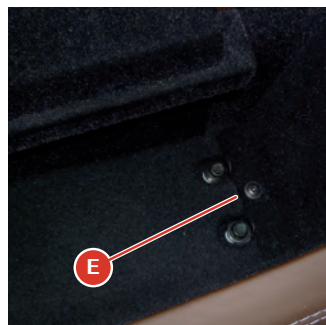
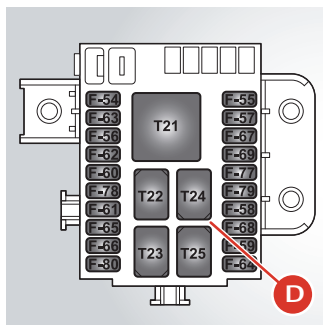



Replacing a wheel

Important note



If one or more wheels need to be replaced, proceed as follows:

- replace the wheel stud bolts with damaged threads or tapers;
- carefully clean the wheel stud bolts before fitting;
- do not lubricate the contact surfaces between the stud bolt and the wheel rim and between the wheel rim and the brake disk.

In order not to remove the antilock coating, do not clean the wheel rim cones with solvents or aggressive products.

Collapsible spare wheel

On request, the vehicle comes with a kit containing:

- collapsible spare wheel **A** with space-saving tyre; the label **B** indicates the maximum speed allowed of 80 km/h;

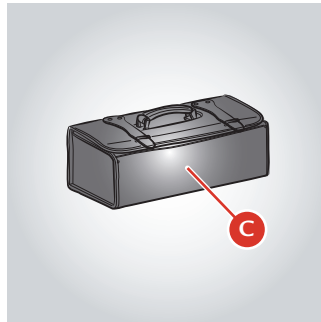
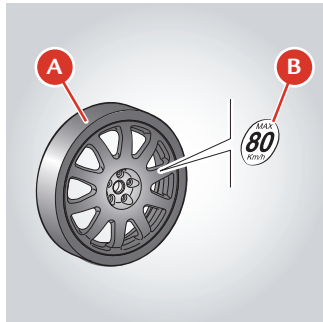

- additional tool bag **C** containing: jack and wrench to fasten the wheel stud bolts.

Warning



The spare wheel must only be used for short trips in the event of an emergency.

When the spare wheel is fitted, never exceed the maximum speed of 80 km/h and drive carefully, especially around bends and when overtaking, avoiding sudden accelerations or braking.

Do not exceed the approved weight limits.

Do not fit snow chains on the spare wheel.

Never fit more than one spare wheel at a time.

Important note



Failure to comply with these instructions could lead to loss of control of the vehicle and consequently damage to the vehicle and injuries to its occupants.

4



Replacing a wheel

- Position the vehicle on an even surface, then block the rear wheels by applying the parking brake.

Warning



Make sure that the vehicle is in a safe position.

- If necessary, switch on the hazard warning lights and place the hazard triangle at the required distance from the vehicle.
- Take the spare wheel and tools out of the luggage compartment.
- Loosen the five wheel stud bolts approximately one turn each using wrench **D** supplied.
- Place the base of the jack **E** on flat firm ground under one of the jacking points **F** on the underfloor as shown in the figure.

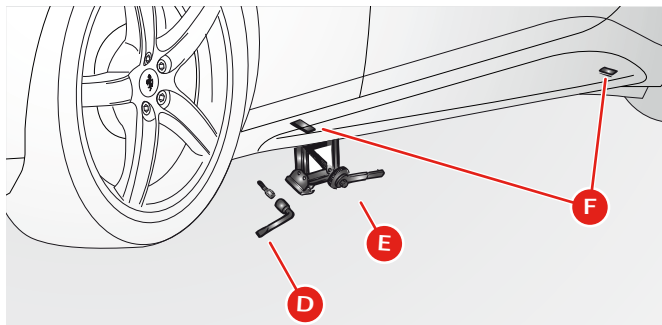

- Lift the vehicle carefully using the jack **E** until the wheel is raised off the ground.

Warning



If the jack is not positioned correctly, the vehicle could slip off. No part of the body must ever be under the vehicle. The provided jack must only be used for replacing wheels.

- Unscrew the five stud bolts and remove the wheel.
- Fit the uninflated collapsible spare wheel.
- Screw the stud bolts into place but do not tighten them.

Warning



Inflate the collapsible spare wheel before lowering the vehicle to avoid damaging the rims.

- Inflate the collapsible spare wheel using the inflation kit.



Warning



The kit must be used in “tyre inflation” mode. Refer to the instruction manual provided with the kit.

- Inflate to the indicated pressure (see page 30).
- Lower the vehicle and remove the jack.
- Tightly fasten the stud bolts, alternately going from one stud bolt to one that is diametrically opposite.

As soon as possible, secure the stud bolts with the torque wrench and tighten them to a torque of 100 Nm.

Warning



The space saver spare wheel does not have a tyre pressure monitoring sensor (see label on spare wheel tool bag). After fitting, it is not checked by the system but complies with international regulations ECE R64/01.

After fitting, we recommend that you go to the nearest **FERRARI SERVICE NETWORK**.

Towing

When towing the vehicle, avoid using anchor points that are not those for the tow hook **A** inserted in place **B**.

- Take the tow hook **A** out of the tool bag.
- Tightly screw the tow hook into place **B**.
- Release the EPB.
- Release the Park Lock.

Warning



If there is an electrical system failure, release the EPB and Park Lock manually (see pages 244-246).

Warning



While towing the vehicle, you must comply with Road Regulations.

4

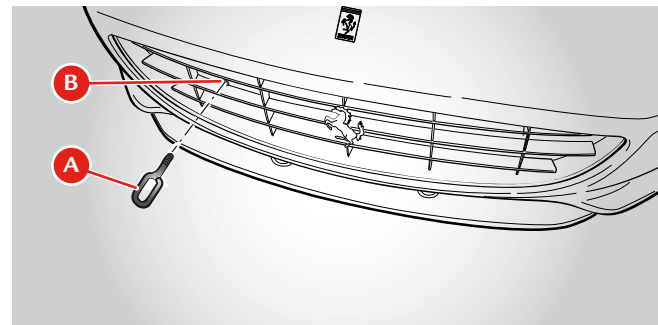



Warning



Do not tow the vehicle by attaching to levers, suspension and wheel rims but only to the tow hook properly fitted in place.

Keep the key in position II to enable the lights to work and prevent the steering wheel from locking if it is turned; when towing the vehicle, do not start the engine.

Important note



Remember that when the engine is switched off, the power steering and brake servo functions do not work.

Fuel inertia switch

This is a safety switch **A** located in the passenger compartment, on the floor in front of the driver seat, which deactivates the fuel pump relays if a collision occurs.

A symbol on the TFT display and the hazard warning lights come on to indicate that the switch has been activated.

When activated, the doors are also unlocked (if locked) and the central dome light comes on.

Warning



The system can be reactivated by pressing the button on the top of the switch.

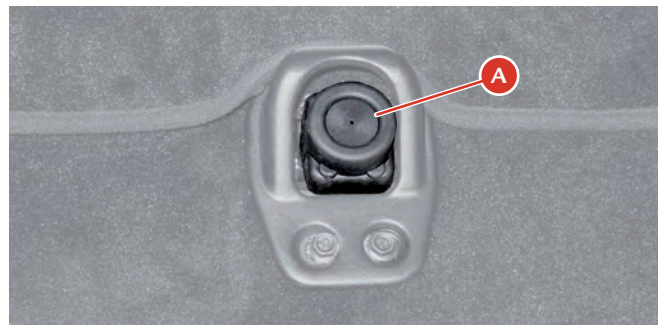



Battery quick release

It is on the battery and can be accessed by opening the engine compartment lid and removing the central cosmetic shield.

Use the locking lever **B** to loosen the clamp.

Separate the clamp from the battery to disconnect the battery and the electrical system.

Warning



The battery master switch must only be used if the battery conditioner cannot be connected.

Warning



Place the clamp so that it does not come into contact with the battery pole or other metal parts of the vehicle.

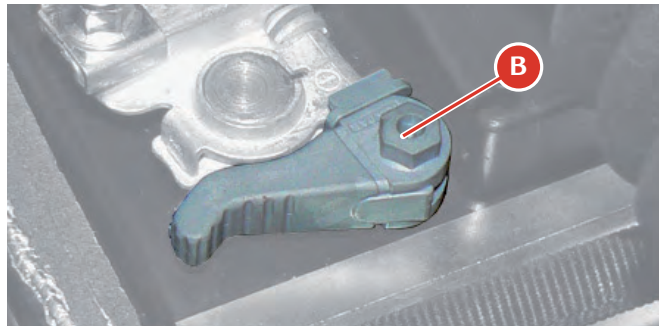

Disconnecting the battery

Before disconnecting the battery, deactivate the electronic alarm using the remote control.

Warning



The battery quick release connector may only be used by qualified personnel, should it not be possible to connect the battery conditioner.

The battery is an integral component of the vehicle, and required the vehicle itself to be used frequently in order to function correctly.

Infrequent vehicle usage may reduce battery performance or result in complete battery failure. Constant usage of the specific battery conditioner provided by FERRARI for each model ensures that the original battery installed in the vehicle is kept charged correctly and in working order.

Warning



Never disconnect the battery from the electrical system when the engine is running. Before disconnecting the battery, lower the side windows by at least 2-3 centimetres to avoid damaging the strips when opening and closing the doors.



Warning



When the battery is connected and charged, this operation is automatically performed when the doors are opened and closed. The windows must remain lowered until the charged battery is reconnected. If the battery is discharged with the windows completely raised, only open the door if necessary and use the utmost caution; do not close the door again until the windows can be lowered.

Important note



We recommend using the battery conditioner if the vehicle is going to left unused for a long period.

Reconnecting the battery

Place the clamp on the battery and fasten it by closing the locking lever.

Each time the battery is reconnected, do the following before starting the engine:

- close both doors and close the luggage compartment lid; unlock and lock the doors using the remote control; open the luggage compartment lid using the remote control;
- adjust the clock (date and time on instrument panel);
- close both doors and fully raise the driver side and passenger side windows to their upper limit; check that the windows move down to the “target position” when the doors are opened.

Warning



WAIT at least 1 minute before inserting the key in the ignition switch.

Before starting the engine, wait at least 60 second with the ignition key in position II to allow the electronic system that controls the motor-driven valves and the AC ECU to run a self-acquisition process.

During this period, no devices must be activated.



The Motronic ECU self-acquisition cycle will only function correctly when the intake air temperature is above 5 °C (41 °F).

After removing the battery from the vehicle or disconnecting it from the electrical system using the battery master switch, it is important to check that the external temperature is within the indicated values when reconnecting before performing the self-acquisition cycle.

Checking the battery

The battery is placed in the centre of the engine compartment. The vehicle is equipped with a sealed lead acid battery that does not require maintenance.

Warning



The battery does not need topping up with distilled water or sulphuric acid.

- Periodically check that the terminals and pins are clean and firmly secured.
- Visually inspect the outer casing for any cracks.
- If the battery overcharges, it will wear out quickly. Have the vehicle electrical system checked if the battery tends to discharge easily.

Warning



Do not place the battery near sources of heat, sparks or naked flames.



Emergency starting

If the battery is flat, you can perform an emergency start by connecting the special jump leads to the battery of another vehicle, a portable jump starter or an external battery.

Important note



Emergency starting can only be performed with batteries with a nominal voltage of 12 V.

Important note



For emergency starting, only use leads that do not allow reverse polarity, with sufficient cross-section and insulated clamps.

To perform an emergency start, do the following:

- Apply the parking brake.
- Deactivate all the electrical devices.
- Remove cover of the fuse box located above the positive terminal on the right side of the battery.
- If emergency starting is performed using the battery of another vehicle, leave the engine on the other vehicle to idle.
- Using the jump leads, connect the positive terminal of the battery to the positive terminal of the portable jump starter or external battery going from the battery on your own vehicle.
- Connect the negative terminal of the portable jump starter or external battery to an earthing point on your vehicle using the jump lead going from the external battery.
- Start the engine.
- Disconnect the jump lead from the earthing point and then from the positive terminal of the battery on your vehicle.

Warning



The emergency start procedure must only be performed by a specialised FERRARI SERVICE NETWORK centre.



Battery conditioner

The vehicle is equipped with a battery conditioner to maintain and recharge the battery.

Important note



If a battery is not periodically maintained, it will become irreversibly discharged. The time taken to reach this state depends on the battery charge level and we therefore recommend that you always use the battery conditioner when parking for over 70 hours.

The device is kept in a pocket inside the car cover bag supplied with the vehicle. The socket for the battery conditioner is installed at the back of the vehicle on the luggage compartment lid next to the number plate light.

Connection is via a magnetic coupling.



Warning



Place the battery conditioner where it can be easily seen away from heat sources and out of children's reach.

If the car is going to be left unused for periods longer than one week, we recommend that you connect the battery conditioner in order to keep the battery in good working order.

Warning



To avoid damaging the conditioner and vehicle, always disconnect the magnetic coupling before starting the vehicle.

Important note



Additional more detailed technical and safety information on use of the device can be found in the leaflet supplied with the vehicle.

4





Exhaust system overheating alarm devices ("Slow Down" function)

If the engine is running unevenly resulting in exhaust system overheating, the "Slow Down" function is activated: a special symbol (see page 149) appears on the TFT display accompanied by a message.

The message varies according to three alarm levels:

- **Temperature high:** "Catalysts temp. high. Slow down".
- **Temperature too high:** "Catalysts temp. too high. Engine performance limited".
- **Catalytic converter temperature system failure:** "Catalysts temp. not plausible. Go to dealer slowly".

Displaying of the message is controlled by the thermistor via the engine control ECU.

Warning

Incorrect use of the vehicle may cause the "Slow Down" function to be activated.

Warning

If the temperature is **high**:
slow down immediately so that the exhaust system temperature decreases.

Warning

If the temperature is **too high**:
the temperature in the catalytic converters has reached a dangerous level and could damage them; if you continue to drive, the engine control ECU intervenes and reduces the torque produced by the engine.
The torque limit remains active until the catalytic converter temperature goes down to normal operating values.

Warning

If catalytic converter temperature system failure information is displayed:
- the engine control ECU intervenes and reduces the torque produced by the engine;
- the driver must slow down and slowly drive to the nearest FERRARI SERVICE NETWORK to have the engine parameters checked.

Warning

If the EOBD warning light (see page 149) comes on at the same time as the "Slow Down" message, go to the FERRARI SERVICE NETWORK to have the ECU error memory checked. Do not proceed in any other way.



Clutch overheat alarm devices

High performance use of the vehicle at high engine speeds for prolonged periods and at high ambient temperatures may cause the DCT gearbox clutch to overheat. In this case, the following safety warnings will be displayed on the TFT display, corresponding to two different alarm levels:

- The message “Clutch overheated”.
- The message “Clutch overheated” accompanied by an audible warning signal.

When the message “Clutch overheated” is displayed, the driver may notice a difference in the behaviour of the system during gearshifts and/or during standing starts.

Important note



Certain high performance actions (such as, but not limited to: “LAUNCH” control start, standing start with wheelspin with Manettino set to ESC OFF, etc.) may be inhibited to prevent excessive overheating of the clutches: the system warns the driver that the action is not permitted, visualising the message “Operation not admissible” on the TFT display.

Warning



As soon as any of the warnings described above appear on the TFT display, the driver must slow down and continue driving at an engine speed between 2000 and 3000 rpm and minimising gear shift frequency to allow the clutches to cool down as quickly as possible, and maintain these driving conditions until the message “Clutch overheated” is no longer displayed.

Engine malfunction alarm devices

If the “**Engine diagnostic system failure**” (EOBD) warning light flashes or illuminates permanently while the engine is running, it indicates that the engine or the emission control system may be malfunctioning.

The electronic system detects and isolates the error preventing damage to the engine or the production of harmful emissions.

Warning



When the “engine diagnostic system failure” warning light comes on, engine performance may be considerably reduced. Drive carefully, avoiding sudden acceleration and high speeds. Contact the FERRARI SERVICE NETWORK immediately.

4

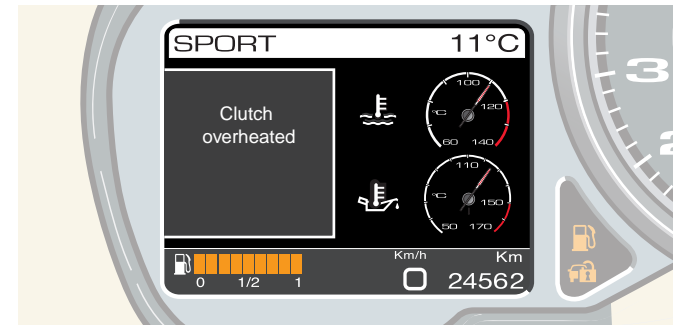



Replacing the brake pads and discs

Brake pads

The front brake pads have a wear detector connected to the brake warning light; if this warning light comes on or braking is not even, have the pad thickness and the state of the braking surfaces checked.

The minimum brake pad thickness is 3 mm (thickness of the friction material only).

Replacing brake pads

When the brake failure warning light comes on, it means that the front brake pads are excessively worn and must be replaced immediately.

Warning



To guarantee the quality of the components and proper installation, we recommend that you have the brake pads replaced at a **FERRARI SERVICE CENTRE**.

After replacement, avoid sudden braking until the new pads are seated properly (approximately 300 km).

Manual closing of the retractable hard top

Warning



For manual closing of the retractable hard top, two people are required.

The movements must be slow and synchronised.

If the retractable hard top cannot be moved electronically, it can be closed and moved manually. To perform the operations described below, two people are required.

- Completely lower the side windows.
- Open the luggage compartment lid.
- Disconnect the battery by detaching the quick release.
- Lift up the luggage compartment lid.
- Open the left **A** and right **B** sections of the luggage compartment by turning the relative fasteners **C**.

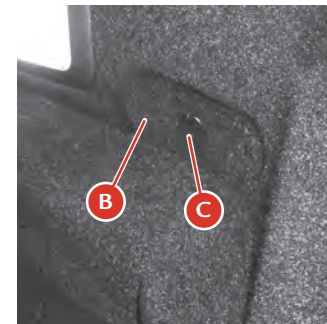
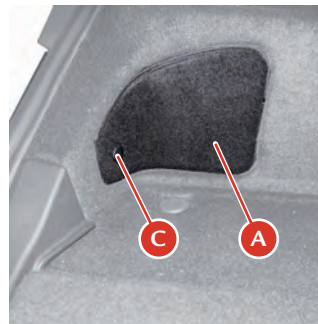



- Locate the Tonneau Cover latch **D** in the left section.
- Locate the Tonneau Cover latch **E** in the right section.
- Insert the special wrench in the tool kit supplied with the vehicle in the Tonneau Cover housing.
- Turn the wrench clockwise to release the left Tonneau Cover latch and turn the wrench counterclockwise to release the right Tonneau Cover latch.

Warning



Make sure that flaps **F** and **G** shown in the figure have opened correctly. If they are not fully open, **DO NOT** effect the emergency manoeuvre to avoid causing possible damage.

- Lower the luggage compartment lid.

Warning



DO NOT close the luggage compartment completely.

4

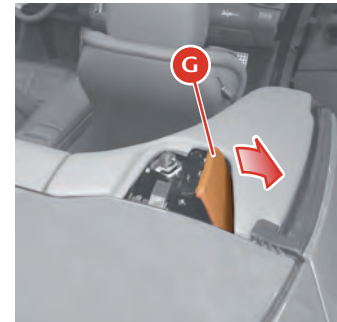
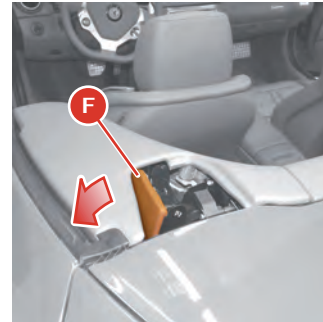
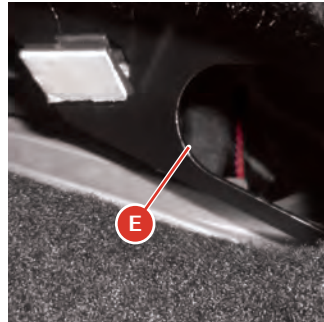
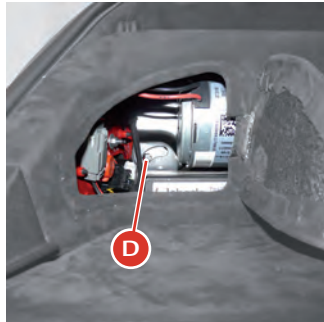



Important note



When manually opening the retractable hard top, special care must be taken not to damage the internal mechanisms which may jam during the initial lifting stage when the system is not hydraulically operated.

To avoid damaging the mechanisms, when first manually opening the retractable hard top (**Fig. 1**), simply push the RH and LH kinematic hooks (**Fig. 2**) towards the front of the vehicle while the top is being lifted (**Fig. 1**).

Once the Tonneau Cover has been raised by approximately 100 mm without forcing it, you can continue to open it by releasing the hooks in **Fig. 2**.

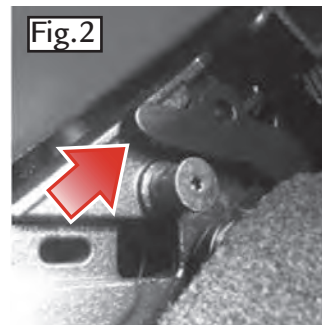
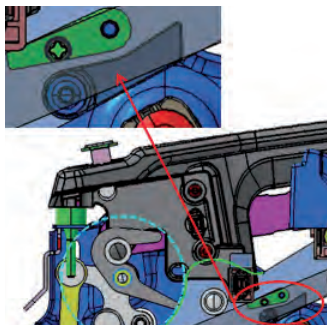



- Lift up the Tonneau Cover until it is completely open.

Important note



Two people are required to open and close the retractable hard top using slow, synchronised movements.
Use the holds as shown in the figure by the arrows.



- Hold the front - rear roof package stored in the luggage compartment and get ready to lift it.

Important note



To do this, hold the package with both hands working on both sides of the vehicle.

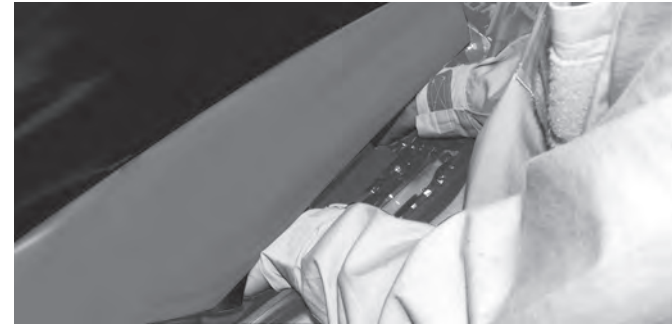

4



- Lift the front-rear roof package right up and let it drop down until it touches the windscreen pillars.
- Lower the Tonneau Cover and let it drop until it has gone into its housing.

- Lift up the luggage compartment.
- Lock the Tonneau Cover latch.
- Insert the wrench in housing **D** on the left of the luggage compartment and turn it counterclockwise.
- Insert the wrench in housing **E** on the right of the luggage compartment and turn it clockwise.

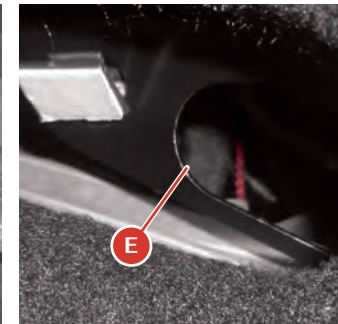
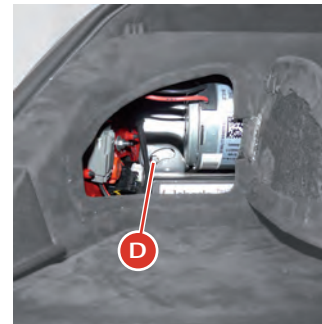



- Close the rear roof by holding it with both hands and working on both sides of the vehicle and let it drop down until it goes into its housing.

Warning



To do this, hold the rear roof with both hands and work on both sides of the vehicle.

- Move the roof internal covering fabric **H** until you find the rear roof latch **I**.
- Release the rear roof latch by turning the special wrench clockwise; do this in the left lock and then the right one by turning the key very carefully to avoid damaging the cover.

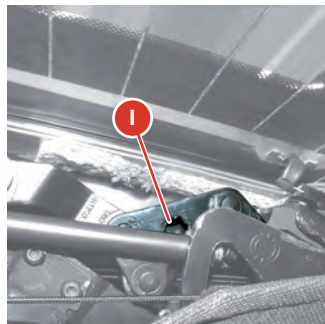

Warning



Make sure that it has locked and if not, repeat the procedure.

- Reposition the fabric on both sides.
- Close the left section with fabric **A**.
- Close the right section with fabric **B**.
- Fasten both covers by turning the fasteners **C**.
- Close the luggage compartment lid.

4

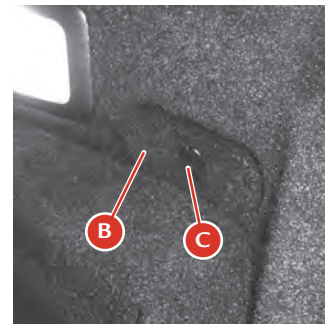
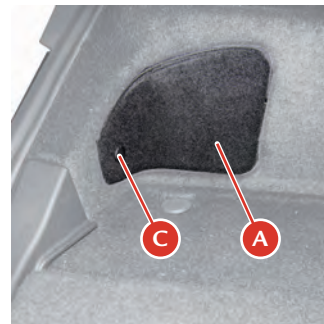



Emergency release of the electric parking brake (EPB)

Warning



The release procedure must only be carried out by specialised workshop technicians.

If the system cannot be released, contact the nearest **FERRARI SERVICE CENTRE**.

Warning



When the electric parking brake is deactivated manually, the vehicle may move unexpectedly!

To keep the vehicle stationary, the Park Lock safety device must be applied: make sure that the letter **"P"** appears on the gearbox display.

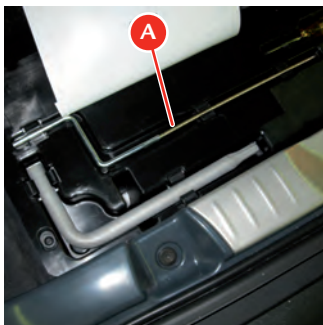

If the vehicle needs to be moved but the electric parking brake cannot be deactivated because the battery is flat or there is a failure in the electrical system that controls it, the emergency release procedure described below must be performed.

- Open the luggage compartment lid.
- Remove the tool kit cover.
- Take wrench **A** for EPB emergency release out of the tool bag.

Warning



Wrench **A** may only be used by specialised workshop personnel, as indicated in the label **C** on the toolkit itself





- Using the special rectangular slot **D** on the LH side of the tool kit (indicated by a plate), place the release wrench in the hole (in the top of the slot) and turn it clockwise.

This movement loosens the parking brake cables.

Important note



To release the brake completely, the wrench needs to be turned 50 times and it starts to be released after approximately 20 turns.

Once the electric parking brake has been manually released, the EPB node records a failure at the next key-on and a symbol and the following message “Parking Brake system revision. Go to dealer” is displayed on the TFT display.

Warning



The parking brake resumes normal operation but it is important to go to the nearest workshop to have it calibrated and delete any errors in the error memory.

Go to a **FERRARI SERVICE CENTRE**.

Calibration is necessary for safety reasons.

4





Park Lock emergency release

Warning



The emergency release procedure must only be carried out by specialised workshop technicians.

If the system cannot be released, contact the nearest **FERRARI SERVICE CENTRE**.

Warning



This should be avoided unless absolutely necessary:

- to tow the vehicle;
- if there is a Park Lock failure (the following message is shown on the TFT display: “Only manual unlock gearbox allowed: See handbook”).

Warning



When the Park Lock safety device is deactivated manually, the vehicle may move unexpectedly.

The vehicle is only kept stationary by the parking brake, if applied.

To perform the Park Lock emergency release procedure, do the following:

- Take the wrench **B** out of the tool kit.

Warning



Wrench **B** may only be used by specialised workshop personnel, as indicated in the label **C** on the toolkit itself.

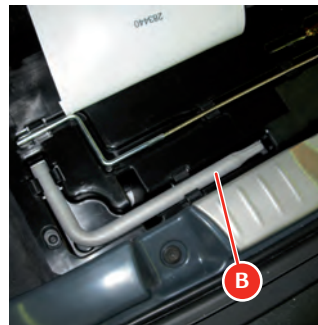



The Park Lock manual emergency release device is located in the top right of the luggage compartment floor, as shown by the arrow in the figure.

- Remove the rubber cap **F** that protects the device.
- Insert the wrench **B** in its seating on the device.

Important note



Make sure that notch **G** of wrench **B** fits onto pin **H** in the housing of the device.

- Turn wrench **B** counterclockwise for a quarter turn.

If the electrical system allows it, check that the letter “N” appears on the gearbox display by turning the ignition key to position II. The following message appears on the TFT display: “Gearbox not in Parking position”. At the same time, an audible signal is repeated four times to indicate that it has been released.

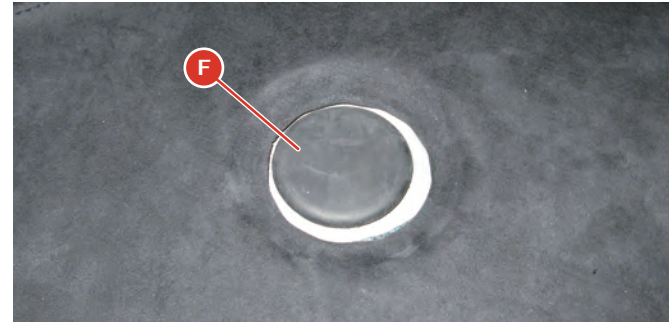

Important note



Once the vehicle has been moved to a safe place, the Park Lock device must be reset.

4

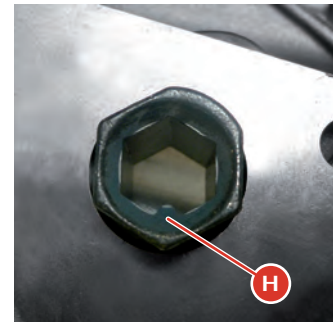
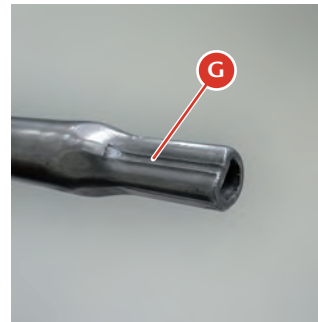
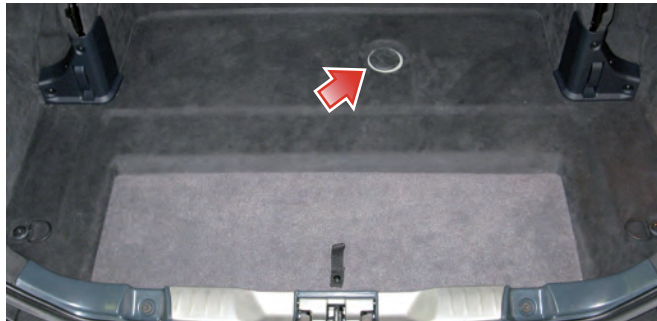



To reset the Park Lock, do the following:

- Insert the wrench **B** in its seating on the device, in the luggage compartment.
- Turn the wrench clockwise.

If the electrical system allows it, check that the letter “**P**” appears on the gearbox display by turning the ignition key to position **II**.

- Close the device with the rubber cap.
- Close the luggage compartment lid.

Warning



In the event of emergency unlocking due to a Park Lock failure, go to the nearest **FERRARI SERVICE CENTRE** to resolve the problem.

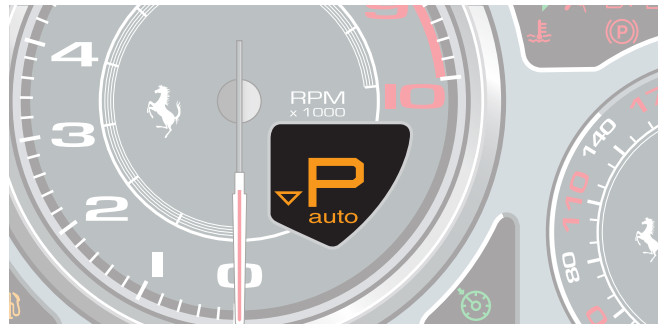
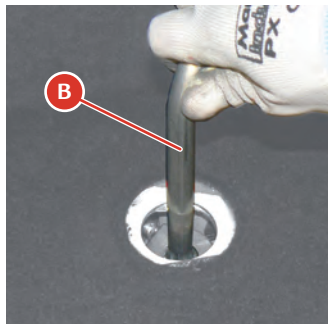





1. General

2. Safety

3. About your Vehicle

4. Advice for Emergency Situations

5. Care of the vehicle

6. Glossary

7. Table of Contents







Warranty Booklet

The vehicle comes with a “Warranty Booklet”.

This contains the vehicle’s warranty validity conditions.

Warning



The warranty booklet also contains special blank spaces where the FERRARI SERVICE NETWORK can register the regular maintenance services performed, as indicated in the maintenance schedule.

Maintenance

It is essential to always keep the vehicle in proper working order to ensure a long working life and to prevent any running defects, caused by negligence or lack of maintenance, and consequently to avoid hazardous situations.

Important note



All repair work on any safety system component must be performed by the FERRARI SERVICE NETWORK.

Maintenance schedule

At the intervals prescribed, the FERRARI SERVICE CENTRES must perform all the fine-tuning and checking operations indicated in the “Warranty Booklet”.

It is however advisable to immediately report any small fault which may occur during use of the vehicle (e.g.: small leaks of essential fluids) to FERRARI SERVICE CENTRES and not wait until the next service is due to correct the problem.

Periodic maintenance services must be performed at least once a year even if the specified mileage limit has not been reached (see “Yearly Maintenance” in the “Warranty Booklet”).

Chassis and bodywork maintenance

The chassis has technological and manufacturing specifications that require that any operation be performed by staff specially trained to work with this innovative technology.

It is of crucial importance to use equipment tested by FERRARI if the repair work is to be performed in accordance with rules of good workmanship. Proper execution of repair work ensures that the commercial value of the vehicle is preserved and the safety standards are complied with.

Important note



If the chassis is damaged in an accident, FERRARI advises customers to contact the FERRARI SERVICE NETWORK who will perform the necessary safety checks.

The chassis, under standard conditions of use, requires no maintenance; it is however advisable to contact the FERRARI SERVICE NETWORK at the intervals indicated in the “Warranty Booklet” in order to have it checked.



Level checks

Important note



The level checks must be performed at the intervals indicated in the “Warranty Booklet” or, in any case, before starting a long journey.

Environment



All the materials used for the following operations (e.g. cloths soaked with oil or grease, pans, etc.) must be disposed of in compliance with the environmental protection regulations.

Important note



Only use lubricants and/or fluids recommended by FERRARI (see the “Refilling” table on page 36).

Engine oil

Warning



The engine oil level must be checked when the engine is warm.

Warning



The engine oil level must be checked when the vehicle is on level ground.

The symbol, shown below, on the TFT display and the message “Check engine oil level” inform the driver that the engine oil level must be checked.



Proceed as follows:

Run the engine until the engine oil temperature has reached 90 °C (194 °F).

- A. Keep the engine idling (720 RPM) for 5 minutes.
- B. Switch off the engine.

Warning



The oil must be checked when the ENGINE IS OFF.

- C. Open the engine compartment lid.
- D. Completely remove the dipstick **1** on the left side of the engine.

5



- E. Remove the oil filler cap **2** and wait 5 minutes for the oil to drain back into the oil pan.

Warning



If the oil level is below the “MIN” reference mark, top it up and then have the system checked by the **FERRARI SERVICE NETWORK**.

- F. Clean the dipstick, reinsert it, remove it and check that the oil level on dipstick **1** is between the **MIN** and **MAX** reference marks.

Important note



The distance between the **MIN** and **MAX** reference marks corresponds to approx. 1.3 litres of oil.

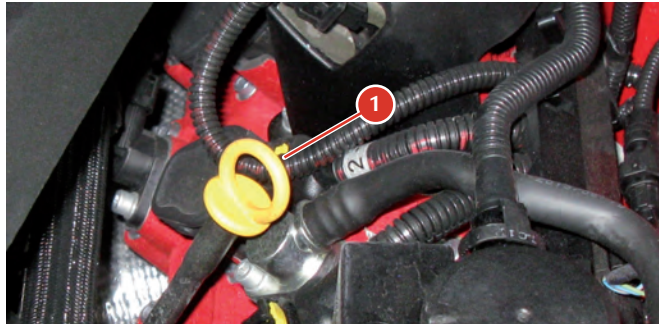

Warning



DO NOT add oil with different characteristics from those of the oil already in the engine.

If the level is close to or under the **MIN** reference mark, top up with the recommended oil.

Warning



DO NOT fill beyond the **MAX** level.

- G. Top up until the oil reaches the **MAX** mark on the dipstick. After topping up, the “low oil level” warning light on the TFT display may remain on for some time. This will allow the system to perform all the necessary checks.



You should therefore consider this behaviour normal.

H. When you have added or changed the oil, check the oil level once again as indicated above.

Environment



Top up with due care to avoid pouring the oil out of the filler neck.

DCT electronically controlled gearbox oil

Important note



We recommend that you have the oil level of the electronically controlled gearbox checked by the **FERRARI SERVICE NETWORK** or by skilled staff.

Coolant

Warning



This procedure must always be performed when the engine is cold. Never remove the cap from the expansion tank when the engine is running or warm.

- Remove the cap **3** from the expansion tank in the engine compartment and check that the level is at approximately 40 mm from the top of the filler neck.
- If the level is low, top it up with the recommended fluid.

Important note



If frequent top-ups are required after short trips, have the system checked by the **FERRARI SERVICE NETWORK**.

- Screw cap **3** back on tightly.



5



Hydraulic steering system oil

Warning



The power steering oil level must be checked with the engine warm, after having driven at least 15 km.

Warning



If the oil level is below the “MIN” reference mark, top it up and then have the system checked by the **FERRARI SERVICE NETWORK**.

The power steering tank is located to the left of the engine compartment.

Remove cap 4 from the tank in the engine compartment and check that the level is between the **MIN** and **MAX** reference marks on the dipstick.

The oil level must be checked with the cap resting on the tank.

Top up if necessary with the recommended oil up to the **MAX** reference mark.

Screw cap 4 back on tightly.





Environment



Never dispose of used fluid in the environment.

Brake fluid

- Check that the fluid in the tank is near the MAX level.

Warning



Clean cap **5** before removing it.

- If the level is low, unscrew the cap **5** and top up with the recommended oil taken from a sealed container.



Environment



Never dispose of used fluid in the environment.

Warning



The oil contained in the brake and clutch systems, in addition to damaging plastic, rubber and painted parts, is highly dangerous if it comes into contact with the eyes or the skin.

In case of contact, wash the affected part thoroughly with running water. To avoid any risk, always use protective goggles and gloves.

Keep out from children's reach!

5



Warning



The use of mineral-based fluids will irreparably damage the system rubber gaskets.

Do not use fluids other than those already in the system for topping up.



- After topping up, screw the filler cap back on.

Windscreen and headlight washer fluid

The windscreen and headlight washer fluid tank can be accessed by lifting the engine compartment lid.

- Lift cap **6** and fill the tank with the recommended fluid (see the “Refilling” table on page 36) until it can be seen in the fluid filling manifold.
- Close the cap **6**.

Wheels and tyres

To ensure maximum performance and tyre life and to permit the best tyre adjustment on the wheel rim, it is important to comply with the following instructions for the first 200/300 km with new tyres:

- avoid sudden acceleration;
- avoid sharp braking and steering;
- drive at moderate speed on straight roads and on curves.

How to use the tyres

Important note



To ensure safe driving, the tyres must be kept in good condition.

The inflation pressure must correspond to the specified values and must be checked only when the tyres are cold since tyre pressure increases as tyre temperature increases.



Never reduce the pressure if the tyres are hot.

Environment



Periodically check the tyre pressure. Driving with the tyres inflated to the correct pressure helps to reduce fuel consumption.

Low tyre pressure can lead to overheating, internal damage and even destruction of the tyres.

Warning



Inflating the tyres to a pressure other than the specified value will render the TPMS monitoring system ineffective.

Sudden impact with pavements, potholes and other obstacles of various types as well as long trips on rough roads can cause damage to the tyres that is not always visible to the naked eye.

Check the tyres regularly for any signs of damage (e.g. scratches, cuts, cracks, bulges, etc.).

If sharp objects penetrate the tyres, they can cause damage which is only visible when the tyre is removed.

Have any damage inspected by an expert as it may considerably reduce tyre life.

Remember that tyres deteriorate over time even if they are rarely used or not used at all.

Cracks in the tread and side walls, possibly accompanied by bulging, are sure signs of ageing.

Warning



The maximum speed supported by the winter tyres (see page 31) is lower than that supported by the summer tyres. Always check the maximum speed rating indicated on the tyre by the tyre manufacturer.

Warning



The FERRARI SERVICE NETWORK is suitably equipped to replace tyres, and to determine whether a tyre is safe for use.

Have the tyres replaced by the FERRARI SERVICE NETWORK that has the necessary equipment available to avoid causing damage through carelessness to the sensor located inside the wheel rim (on vehicles with the tyre temperature and pressure monitoring system - TPMS).

Important note



The FERRARI SERVICE NETWORK can certify whether aged tyres are suitable for use.

Warning



Replace the tyres at intervals no longer than 4 years of normal usage, even if the maximum mileage specified has not been exceeded.



Never fit tyres of uncertain origin.

Warning



The tyres are of the “directional” type and there is an arrow marked on their side wall to indicate the direction in which they must rotate or which side is the outer side. When replaced, maximum performance levels can only be ensured if the rotation direction corresponds with the direction indicated by the arrow. Tyres on the same axle must always be replaced in pairs.

Regularly check the tyre tread (minimum acceptable depth **1.7 mm**). As the tread wear increases, there is a greater risk of skidding.

Warning



Drive carefully on wet roads to reduce the risk of “aquaplaning”.

Wheel alignment check and adjustment

When you notice unusual wear of the tyres and in any case, at the intervals prescribed in the “Warranty Booklet”, have the **FERRARI SERVICE NETWORK** check the wheel toe-in and camber.

Maintenance of seat belts and pretensioners

- Periodically check that the screws on the anchor points are tight and that the seat belt is in perfect condition and slides smoothly.
- The seat belt must be kept clean; the presence of any dirt could prevent the seat belt retractor from working properly.
- To clean the seat belt, wash it by hand with mild soap and water, rinse it and let it dry. Do not use strong detergents, bleach or aggressive solvents, as they can weaken the fibres.
- Do not let the seat belt retractors get wet: proper functioning is only ensured if they are kept dry.
- The pretensioner requires no maintenance or lubrication. If immersed in water or mud, the pretensioner must necessarily be replaced.
- The pretensioner must be replaced at the intervals indicated in the “Warranty Booklet”.



Cleaning the vehicle

Cleaning the exterior

Environment



All the materials used for the following operations (e.g. cloths soaked with oil or grease, pans, etc.) must be disposed of in compliance with the environmental protection regulations.

Proper care of the vehicle on the part of the owner is essential for the vehicle long life.

Here is a list of the main precautions to be taken:

- Certain parts of the vehicle should not be left wet or dirty for long periods of time: in particular, the passenger compartment floor and the luggage compartment must always be kept clean and dry. The draining holes under the doors should be kept unclogged to allow any water to drain.
- The underbody and the lower surfaces of the vehicle should be cleaned regularly, and more frequently (at least once a week) if the vehicle is used on salty or rough roads. The vehicle should be cleaned thoroughly and carefully: cleaning that merely wets encrusted mud without removing it completely can prove damaging.
- The vehicle must be washed regularly with suitable equipment. Do not use very hot water or steam to clean the paintwork and the lower surfaces. It is advisable to soften any dirt first, then remove it with a jet of water at room temperature.

Important note



Do not use aggressive products for cleaning the windows. The use of aggressive products could seriously damage the bodywork.

- Do not wash the vehicle in direct sunlight or when the bodywork is still warm: make sure that the jet of water does not blast the paintwork; wash the vehicle with a sponge and a mild soap and water solution; rinse the vehicle again with a jet of water and dry it with a chamois leather.

Important note



When the vehicle has been washed, apply slight pressure to the brake pedal at moderate speed before driving at a normal speed, until the brake discs and pads have cleaned off.

In order to maintain the shine on the paintwork, polish it once or twice a year with products recommended by FERRARI.

- Any areas that are cracked or chipped by stones, scratches or parking manoeuvres, etc., must be immediately repaired by the FERRARI SERVICE NETWORK.
- Do not park the vehicle in damp and/or unventilated areas for long periods of time.



Cleaning and care of matt paintwork (optional)

Warning



The paintwork **MUST NOT** be polished using any type of product.

Owners must take great care of vehicles with matt paintwork (optional).

Here is a list of the main precautions to be taken:

- Wash the vehicle using a steam cleaner and rinse with demineralised water only.
- It must be dried using an automatic dryer or compressed air. Manual drying can **ONLY** be performed using a clean 3M microfibre yellow cloth that has been soaked in demineralised water in the areas where limescale deposits are present. The cloth must be kept in a special clean container.
- To clean any grease or oil marks, a clean 3M microfibre yellow cloth soaked in R107/S solvent (heptane) can be used. A new cloth must be used and it must not have been previously soaked in demineralised water.
- Do not wash the car in direct sunlight.
- Wash the vehicle only when the bodywork and engine are cold.
- Do not apply stickers to the bodywork.

- Any areas that are cracked or chipped by stones, scratches or parking manoeuvres, etc., must be immediately repaired by the FERRARI SERVICE NETWORK.

Important note



DO NOT lean against the vehicle especially if you are wearing clothes with buttons, buckles or are wearing rings, necklaces, etc. This may cause irreparable damage to the bodywork.

Important note



To use suitable products, contact the FERRARI SERVICE NETWORK.

Cleaning of protective anti stone-chipping film (optional)

The film has been designed to protect the bodywork: anything that damages the paint will also damage the film.

Warning



Do not pour denatured ethyl alcohol, acetone, isopropyl alcohol, heptane or substances that contain these compounds on the film.

- Do not apply adhesive elements on the film.
- When cleaning, do not use metal or abrasive substances in general and acid chemical compounds.



Important note



Avoid the film coming into contact with the brake fluid: the film will become opaque.

- Do not use solvents along the edges of the film to them from penetrating inside the adhesive layer.

Important note



Nürburgring Silver, Avus White, Alloy Grey, Met Avio, Ivory, Met Light Blue, Met Sky-Blue and Fuji White vehicles must be washed every month and waxed at least twice a year so that dirt, acid rain, pollutants, etc. do not penetrate the pores of the film and cause it to tarnish.

Important note



We recommend replacing the film every 24 months for vehicles in Nürburgring Silver, Avus White, Alloy Grey, Met Avio, Ivory, Met Light Blue, Met Sky-Blue and Fuji White, as the finish quality may deteriorate slightly (yellow tarnish) due to dirt accumulated in the porous surface of the film.

It should be noted that timely and accurate cleaning (monthly washing and waxing twice a year at least) will prevent deterioration of the film.

Cleaning the interior

Cleaning and care of the leather upholstery

As indicated in the “Maintenance Schedule” (see the “Warranty Booklet”), proper and regular treatment, at least once a year, will help preserve the quality, natural characteristics and softness of the leather upholstery in your FERRARI.

With this in mind, specific leather care products are also available (“Cleaner” and “Cream”) both tested by FERRARI.

These products can be ordered through the FERRARI SPARE PARTS SERVICE DEPARTMENT, both individually and as part of the “Care Kit” which includes the complete range of products for cleaning the vehicle.

Important note



For use of the “Care Kit” products, contact the FERRARI SERVICE NETWORK.

The following products must be avoided when cleaning the leather: harsh detergents, turpentine, liquid stain removers, petrol, solvents and domestic cleaning products. All of these products damage the natural material.



Cleaning and care of the Alcantara® upholstery

Warning



Do not use steam cleaners.

- Carefully dust the parts to be cleaned.
- Use a soft cloth or sponge moistened with clean water.
- Thoroughly wring out the cloth and wipe it over the entire Alcantara® area making sure you do not overwet it.
- Repeat the procedure.
- Let it dry completely.
- To recondition the material, gently use a brush with soft bristles.

If the vehicle is stored for long periods

If the vehicle is not used for long periods of time, certain precautions should be taken:

- if possible, park the vehicle on a level surface in a covered and well-ventilated area;
- prevent the vehicle from moving by engaging a gear;
- bring the tyre pressure to 3.0 bar and periodically change the point where the tyres rest on the ground;
- connect the battery conditioner (see page 235);
- protect the vehicle with a breathable fabric cover and avoid materials that prevent any dampness on the bodywork from evaporating.

Before using the vehicle again after long periods of inactivity, adjust the tyre pressure to the indicated pressure and check the fluid levels of all the systems.



Important note



If you do not intend to connect the battery to the battery conditioner, the battery must be recharged at least once every two weeks to keep certain functions, such as the radio station memory, alarm system, etc., working correctly.

The battery is an integral component of the vehicle, and requires the vehicle itself to be used frequently in order to function correctly.

Infrequent vehicle usage may reduce battery performance or result in complete battery failure.

Constant usage of the specific battery conditioner provided by FERRARI ensures that the original battery installed in the vehicle is kept charged correctly and in working order.



1. General

2. Safety

3. About your Vehicle

4. Advice for Emergency Situations

5. Care of the vehicle

6. Glossary

7. Table of Contents





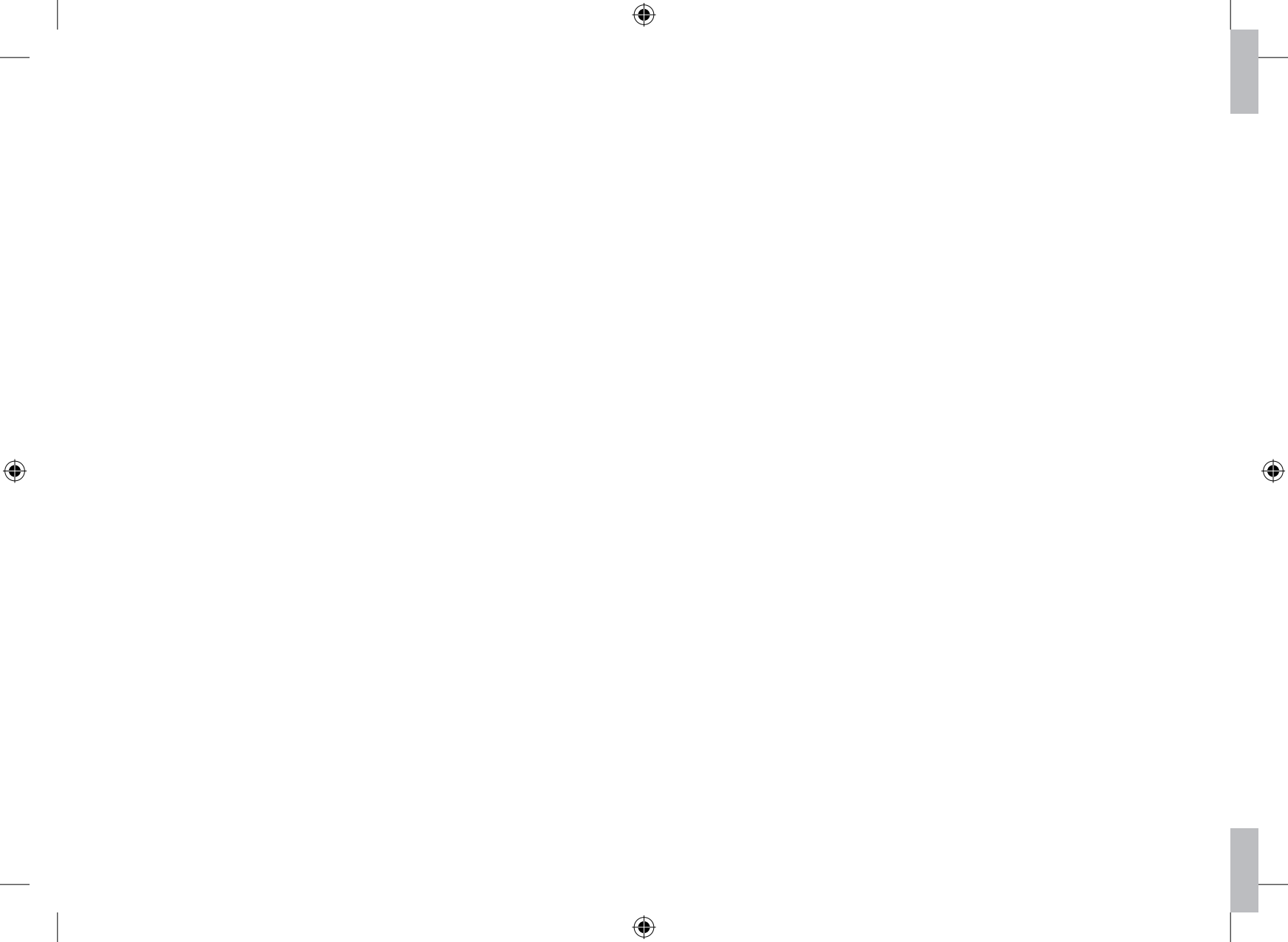



Abbreviation	Meaning
ABS	(Anti-lock Braking System) The ABS prevents wheel locking when braking so that vehicle handling can be maintained.
AC	Air conditioning.
ASR	(Antriebs Schlupf Regelung) Anti-skid regulation during acceleration.
Auto easy exit	Simplified function gear shifting. To exit “Auto easy exit” mode, simply operate one of the two shift paddles.
Autopark	Automatic activation of the electric parking brake (EPB) when the engine is switched off. This function can be disabled.
AVH	Automatic Vehicle Hold Additional function of the electric parking brake (EPB): it allows gradual release of brake shoes/pads when the vehicle starts up. This guarantees an optimised release for the vehicle and is an aid for the driver.
DCT	Dual Clutch Transmission Each clutch is associated with a part of the gearbox, one is designed for engaging even gears, the other for odd gears. Once a gear has been engaged, the system has already preselected the next one. After reaching the correct RPM, a clutch opens and at the same time the other one closes, so that the traction force is not interrupted.
Disposal	The procedure laid down in Directive 2000/53/EC and the implementation standard.
EBD	(Electronic Brake-Force Distribution) Electronically-controlled brake-force distribution.
ECU	Electronic Control Unit.
EPB	Electric Parking Brake The system operates by means of an ECU and an electric motor on the rear brake shoes.
ESC	Stability and Traction Control. It consists of two systems: VDC and F1-Trac.
F1-Trac	Traction control derived from the technologies used in the racing sector. The system can estimate the maximum available grip in advance by continuously monitoring the relative wheel speed and using an auto-adaptive operating logic. Comparing this information with the vehicle dynamics model stored in the control system, F1-Trac, optimises the vehicle behaviour by controlling engine torque delivery.



Abbreviation	Meaning
Homologation	The procedure laid down in Directive 2007/46/EC and the implementation standard.
Launch Control	Strategy for performance standing starts.
Manettino	The driving mode control switch is a quick, intuitive way to make the most of vehicle potential.
Park Lock	Automatic DCT gearbox park lock. When the engine is off, a mechanical lock is automatically activated to prevent the vehicle from moving if the electric parking brake is not activated.
RHT	Retractable Hard Top.
TFT display	Multifunction colour display on the instrument panel that provides vehicle information.
TPE	Turbo Performance Engineer, a display that gives the driver information on turbo engine performance.
TPMS	Tyre Pressure Monitoring System. Using special sensors fitted inside the wheel rims next to the air valve, the data measured is sent to an ECU. The data and messages are displayed on the TFT display.
Traction power	Force exerted by the vehicle on the road surface through the wheels; it indicates the grip.
VDC	Vehicle Dynamic Control performed through the braking system and engine torque.
Xenon headlights	Headlights on the front of the vehicle that produce a more intense beam by using a voltaic arc rather than an incandescent spiral.







1. General

2. Safety

3. About your Vehicle

4. Advice for Emergency Situations

5. Care of the vehicle

6. Glossary



7. Table of Contents







Index

Symbols

12V power socket 204

A

Abbreviations 10
 ABS 68
 Activating Cruise Control 163
 Activation of electronic alarm 17
 Active safety 43
 Adaptive headlights (optional) 129
 “Adaptive Light Control” function display 137
 Adjusting display brightness 133
 Adjusting the air vents 202
 Adjusting the steering wheel 196
 Airbags 56
 Airbag system - Components 56
 Air conditioning and heating system 199
 Air conditioning and heating system controls 199
 Alarm memory 19
 Alarm system 15
 Auto easy exit 172
 “Auto easy exit” mode 172
 Auto Hazard 128

Automatic gearbox 172
 “Automatic gearbox” mode 172
 Automatic Vehicle Holding 70, 184
 Autopark Function 70, 184
 AVH function 70, 184

B

Backrest and seat cushion side width adjustment 195
 Battery 233
 Battery conditioner 234
 Battery quick release 231
 Before a trip 166
 Before you drive 173
 Body Computer fuses and relays 222
 Brake fluid 257

C

Calibrating the TPMS system 75
 Capless filler neck 90
 Carwash 179
 Carwash procedure 179
 Chassis and bodywork maintenance 252
 Child restraint systems that can be installed
 on the front passenger seat with 3-point seat belts 77
 Child restraint systems that can be installed
 on the rear seats with 3-point seat belts 77
 Child restraint systems that can be installed
 on the rear seats with ISOFIX 78



Child safety	50
Cleaning and care of the Alcantara upholstery	264
Cleaning and care of the leather upholstery	263
Cleaning the exterior	261
Cleaning the interior	263
Cleaning the parking sensors	144
Cleaning the vehicle	261
Closing the engine compartment lid	88
Closing the luggage compartment lid	89
Clutch overheat alarm devices	237
Collapsible spare wheel	227
COMFORT mode	160
Configuration of vehicle parameters	132
Consumption	28
Controls on the steering wheel	158
Controls overview	82
Coolant	255
Cruise control	163

D

Day lights	127
DCT electronically controlled gearbox oil	255
Deactivating the anti-lift volumetric alarm	18
Deactivation of electronic alarm	18
Deformable body	43
Dimensions and weights	27
Dome light	129
Doors	86

“Doors/Engine or luggage compartment lid open” function display	138
DOWN-shifting	171
“DOWN” shift paddle	161
Drive Away function	183
Driver and passenger airbags	58
Driver seat Easy Entry/Exit	196
Driver-side power window	92
Driving at night	174
Driving in fog	175
Driving in the rain	174
Driving on mountain roads	175
Driving on snowy or icy roads	176
Driving style	10
Driving the vehicle	165
Driving using the driving mode control switch (“Manettino”)	177
Driving with the “ABS” braking system	176
Dual View Camera (optional)	117
Duplicating the keys	16

E

Electrical system	28
Electric parking brake	183
Electronic alarm	17
Electronic speedometer	95, 153
Emergency opening - Fuel filler flap	91
Emergency opening of fuel filler flap	91



Emergency tyre repair and inflation kit	213
Emissions	28
End-of-life vehicle collection service	11
Engine compartment lid	88
Engine malfunction alarm devices	237
Engine oil	253
Environmental protection	10
EPB - Electric parking brake	70, 181
EPB emergency release	244
“ESCAPE” function	146
ESC OFF mode	160
ESC - Stability and Traction Control	69
Exhaust system overheating alarm devices	236
External lights failure display	140
External rear-view mirrors	198
F	
F1-Trac	69
Failure of turn indicators and running lights	147
Fault display	146
Ferrari CODE system	15
Flaps communicating with luggage compartment	204
Flashing the headlights	125
Follow me home	128
Front parking sensors (activation/deactivation)	158
Fuel filler cap and flap	90
Fuel inertia switch	67
Fuel level	134

Fuel level gauge	134
Fuse	220
Fuses and relays in the engine compartment	222
Fuses and relays on centre console	226

G

Gearbox display	153, 156
General remarks	4
Global Closed	93
Global Open	93
Glossary	269
Glove compartment	202

H

Hazard warning lights	128
Headlight bulbs	216
Headlight washer	162
High beams	125
Horn control	158
How to fasten seat belts	46
How to use the tyres	258

I

Identification and homologation plates and labels	20
If the vehicle is stored for long periods	264
Ignition switch	85
Indication of AVH system activated	155



Indication of Launch Control activated	155
Instruments and gauges	94
Internal rear-view mirror	197

K

Key codes	14
Key lock	85

L

Launch Control	180
Leather upholstery	263
Level checks	253
Light bulbs	219
Lighting	125
Light switch	125
List of TFT display symbols and instrument panel warning lamps	148
Locking and opening the doors from the inside	86
LOCK/UNLOCK	158
Low tyre pressure	72
Luggage compartment lid	89
Lumbar support adjustment	194

M

MAIN	130
Main engine specifications	28
MAIN screen page	130

Maintenance	252
Maintenance of seat belts and pretensioners	49, 260
Maintenance schedule	252
Manettino	159, 160
Manual closing of the retractable hard top	238
Matt paintwork	262
MENU	132
MENU screen page	132

N

N - Neutral	171
Number plate light bulbs	217

O

OK button	130
Opening doors from the outside	86
Opening the engine compartment lid	88
Opening the fuel filler flap	90
Opening the luggage compartment lid	89
Operations not allowed	121
Other light bulbs	217

P

Parking Camera	116
Parking lights	126
“Parking” mode	154
Parking sensors	141



Park Lock	179
Park Lock emergency release	246
Passenger compartment accessories	202
Passenger side fuses and relays	224
Passenger-side power window	92
Passive safety	41
Performance	28
Performance start	180
PIT SPEED	163
Placing suitcases in the luggage compartment	205
Pocket-change compartment	202
Pocket-change compartments	203
Position II - Ignition	85
Power steering	176
Power steering system oil	256
Power windows	92
Pregnant women	41
Pretensioners	48
Push start	172

R

Rear fog lights	128
Rear power windows	93
Rear seat belts	47
Rear-view mirrors	197
Refilling	36, 166
Replacing a fuse	220
Replacing a wheel	227

Replacing number plate light bulbs	217
Replacing other light bulbs	217
Replacing remote control batteries	17
Replacing the brake pads and discs	238
Replacing the headlight bulbs	216
Replacing the supplementary taillight bulbs	216
Replacing the taillight bulbs	216
Retractable hard top	98
Rev Counter	153
Roll bar	65
Roof closing using the switch	120
Roof opening using the switch	119
Roof operation on stand-by	121
Run Flat tyres	35
Running-in	165

S

Safe driving	173
Satellite alarm system	19
Seat adjustment	193
Seat belts - Safety	44
Seat belts - Unfastening	47
Seat heating system	196
Seat position memory	195
SETUP	130
Side airbags	62
“Slow Down” function	236
Spare parts	7



Special Ferrari child restraint systems	78
Special recommendations	40
“Speed limit” function display	138
SPORT 2 screen page	135
SPORT mode	160
SPORT screen page	135
Start button	159
Starting the engine	169
Starting the vehicle	169
STATUS	130
“Stop and Go” function	141
Stopping the vehicle	171
Stop&Start (optional)	185
Stop&Start system (optional)	185
Suitcases in the luggage compartment	205
Sun radiation sensor	202
Sun visors	203
Supplementary taillight bulbs	216
Suspension damping control	181
Switching off the engine	171
System start-up	167
T	
Taillight bulbs	216
Telephone function	114
Tool bag	212
Toolkit	212
Towing	229

TPMS	71
TPMS failure	76
TPMS - Tyre puncture	73
Transmission ratios	28
TRIP	130
TRIP A and TRIP B screen pages	136
TRIP A/B	136
Turbo Performance Engineer display	156
Turn indicators	127
Twilight sensor	127
Tyre inflation pressure	30
“Tyre pressure and temperature” display	139
Tyres	29
TYRES screen page	136
Tyre temperature and pressure monitoring system (TPMS)	71
U	
UP, DOWN, LEFT, RIGHT buttons	130
UP-shifting	170
UP-shifting due to overrevving	170
“UP” shift paddle	161
Use of the vehicle	10



V

VDA	130
Vehicle keys	14

W

Warming up the engine	169
“Warning: danger of ice” display	137
Warning lights on the panel	148
Warning of faulty roof opening and closing	124
Warranty Booklet	7, 252
Wheel alignment check and adjustment	260
Wheel rims	29
Wheels and tyres - Use	258
While travelling	173
Wind deflector	206
Windscreen and headlight washer fluid	258
Windscreen and headlight washer/wipers	161
Windscreen washer	161

Equipment and options in FERRARI vehicle models may vary because of specific legal and market requirements. The information contained in this publication is therefore not binding in any way.

FERRARI reserves the right to make any modification to the vehicle models described in this manual, at any time, for either technical or commercial reasons.

Contact the nearest FERRARI Dealer for any further information you may require.

In the interests of efficiency and safety, as well as to preserve the value of the vehicle, we do not recommend modifying the equipment using non-approved parts.

Code no. 86660200
Catalogue no. 4723/14

EDITION
1st Edition **May 2014**

EDITING
STAR s.r.l.
Alessandria - Italia

PRINTING
STAR s.r.l.
Alessandria - Italia

COPYRIGHT© **Ferrari**



Technical Service Department
Via Abetone Inferiore, 4
41053 Maranello
Modena - Italia